

# LIGHTING

Architectural · Indoor · Outdoor · Fan · Architectural  
**110V**  
COLLECTION  
Architectural · Indoor · Outdoor · Fan · Architectural

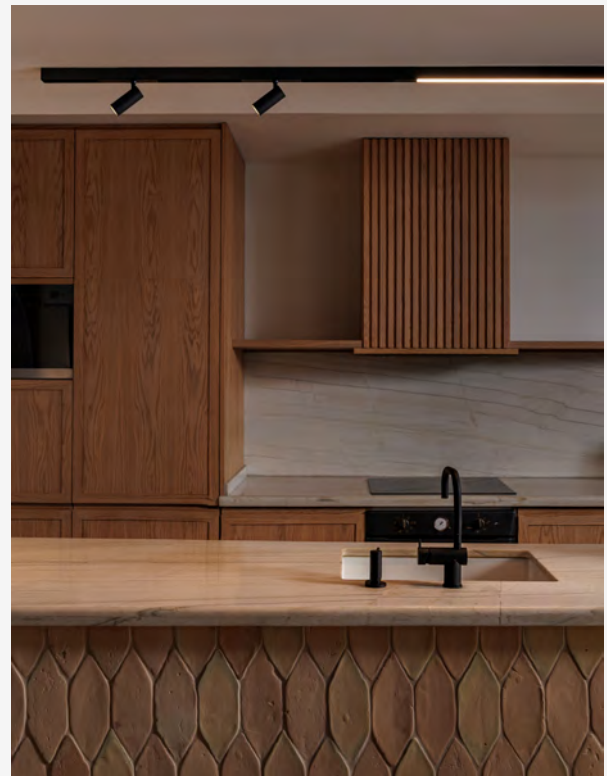

Distributed exclusively by:

**TANGO**  
○ lighting

2901 SW 3rd Ave. Unit # 4, Ft. Lauderdale, FL 33315  
T: 954-767-0100 E: info@tangolighting.com  
www.tangolighting.com

**F A R O**  
BARCELONA



**For a sustainable  
future of forests.**



**Edition:** A2024

**Art:** Faro Art

**Print:** Walstead

**Photographers:**

Guillem F-H

Ricard Badía

Marta Vidal

Javier Marquez Lera

Kioto Studio

Check the current rates here

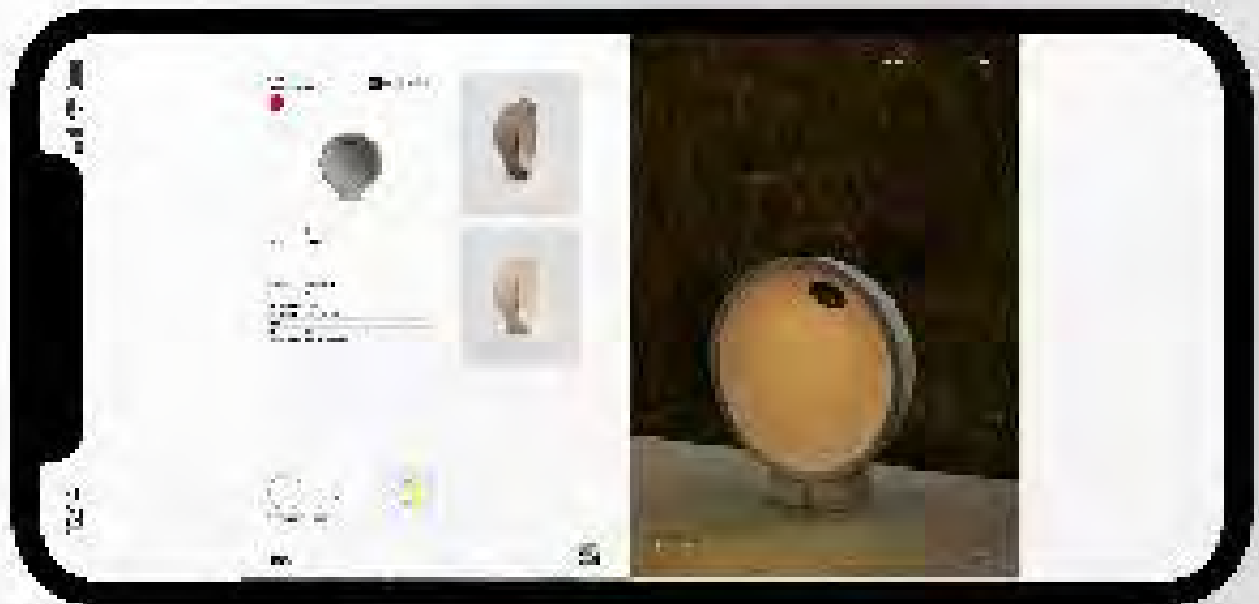



## We're Faro Barcelona

Our purpose	6
A brand with soul	8
Sustainability	10
Awards	16
Designers	18
Showrooms	20
Quality & innovation	22
Services	24



## Indoor Collection

Portables	57
Table & Floor	69
Suspended	177
Ceiling	283
Surface	321
Spotlights	509
Recessed	523
Track	563

## Outdoor Collection

Systems	569
Portables	591
Floor	609
Spikes & Projectors	733
Suspended	795
Downlight	819
Surface	831
Recessed	941



### Architectural Collection

Tracklights	1199
Downlights	1249
Surface	1405
Suspended	1459
Systems	1483
Led Stripes&Profiles	1555
Connectivity	1571
Drivers	1571





## OUR PURPOSE

“Faro Barcelona exists to contribute to the wellbeing and happiness of people through design and the relationship we establish with the objects that surround us in our daily lives. We believe in honest and accessible design. Design for everyone.”

Xavier Martin  
CEO



## A BRAND WITH SOUL

“We believe in the power of enthusiasm to move forward and surf the waves the best way we know while enjoying the process and radiating light around us.”

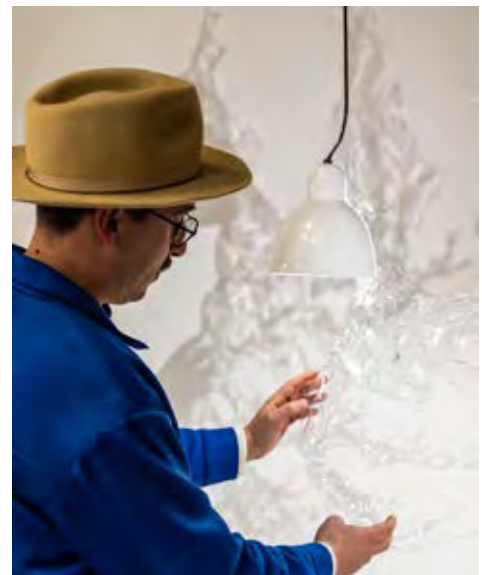







# SUSTAINABILITY

Our sustainability journey focuses on two main objectives: reducing our negative impact on the planet and maximising our positive social impact.



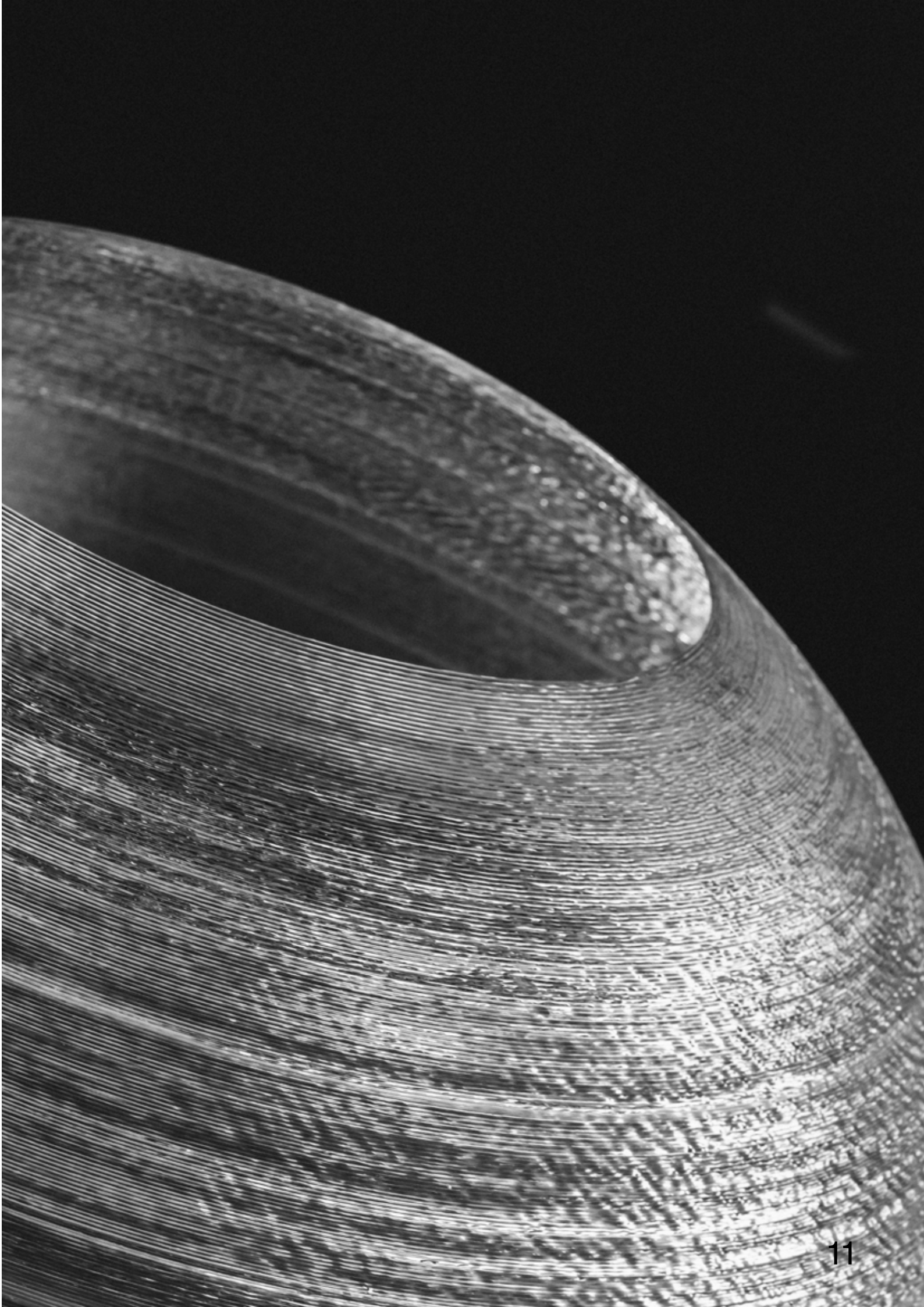



## **People**

### **The value of a great team**

At Faro Barcelona, sustainability starts from the inside, taking care of the well-being and personal growth of our team.

### **Equality and diversity**

At Faro Barcelona all people are great and equal, whatever their gender, age, religion or sexual orientation. Women, as well as men, play an important role: 76% of our team and 49% of our leaders are women.

### **Community support**

For over a decade, we have been collaborating in social projects of foundations providing our help to ensure a better quality of life for the people helped by these organisations. Since 2008, we have had our own social project with Hook, each luminaire sold feeds a child in Africa for one year.

### **Supporting new talent**

We collaborate with universities and design schools to help new talents emerge into their professional development. Projects such as Reborn, a second life for waste (La Llotja), make It design with 3D printing (CIM UPC), are some of the collaborations we have carried out.

### **Social innovation**

We take part in disruptive social innovation research and develop products and services that solve social problems such as the ageing of the population. We have a positive impact on people's quality of life, contributing to their well-being and comfort through quality, accessible and sustainable lighting and design.





## Planet

### Sustainable packaging

Our packaging is made of recycled cardboard boxes printed in one ink and without staples to ease the disassembly and the right recycling.

We have eliminated single-use plastics and replaced them with recyclable paper bags and we use recycled cardboard shavings to protect the product during transport in 60% of our shipments. All our packaging meets Drop Test ISTA-2C quality standards to ensure products arrive in perfect condition.

### More sustainable logistics and transport

We have optimised the packaging size of each product to reduce the amount of packaging material and the carbon footprint of transport. We have opened a new logistics centre in China to supply our Asia-Oceania market in a more sustainable way and reduce carbon emissions from transport.

### Sustainable workspaces

We use green electricity in our offices. We produce 70% of the energy we consume with our own photovoltaic installation, ensuring that the energy is from renewable sources. In addition, our headquarters are designed to maximise the use of solar energy and natural light.

### Supporting new talent Team committed to sustainability

At Faro Barcelona we have an internal sustainability committee that promotes different sustainability actions and monitors them.



## Product

### Sustainability from conceptualisation

In our eco-design decalogue we set out the main guidelines we follow to make our designs more sustainable. We work with external consultants to reduce the environmental impact of our production processes, guaranteeing the quality and safety of our products. We are training our design team in circular design techniques for the more sustainable development of all our products.

### A longer useful life

We work to design timeless, repairable and long-lasting products in order to reduce their environmental impact. We research new methods to ensure that our designs last longer, are easy to repair and can be recycled.

### Standardisation and modularity

We work on the standardisation of components for a more efficient use of resources and more sustainable production. We develop modular collections that allow us greater versatility and more efficient logistics and transport.

### More sustainable processes and materials

One of the major challenges towards a more sustainable production is the choice of materials as it represents more than 70% of the product's carbon footprint. The use of recycled materials or materials with a lower environmental impact, the implementation of new techniques and the reduction of the number of materials used, help us achieve more sustainable manufacturing.

### Control of the supply chain

We share our sustainability vision and commitments with all our suppliers. We, therefore have a supplier code of conduct to ensure a more sustainable supply chain.





## CARBON FOOTPRINT CERTIFICATION

We have achieved certification of our carbon footprint calculation in accordance with the ISO 14064-1 international standard, a major milestone on our path to sustainability.

Thanks to this certification, we know the real volume of greenhouse gas emissions generated by our activity and it allows us to identify areas for improvement and implement compensation strategies through different programs.

We celebrate that we have successfully passed the sustainability audit carried out by EcoVadis, obtaining the prestigious Medal in recognition of our sustainability efforts and achievements.

Both certifications reaffirms our ongoing commitment to sustainability and corporate responsibility in all its facets and operations.

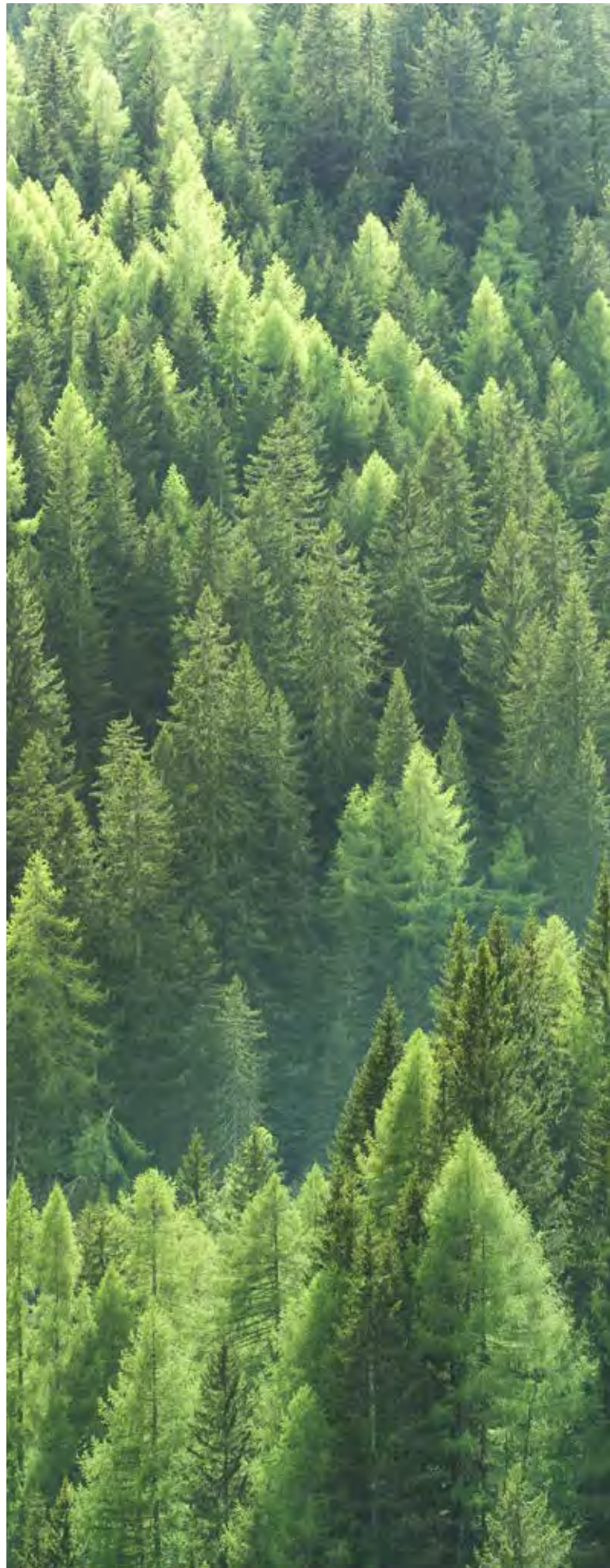









# AWARD-WINNING DESIGNS

Totem by Roger Vancells



reddot winner 2023

Maya by Faro Lab



reddot winner 2023

Buddy by Andreu Carulla



Inviting by Bohman & Folenius



reddot award 2019  
winner



Cadaqués by Faro Lab



Hook by Oiko Design Office



reddot award 2018  
winner



Fuji by Isaac Piñeiro



reddot winner 2021  
lighting design



Brot by Yembarastudio



reddot winner 2022

Mine by Nahtrang



Whizz by Christoph F. Wagner



Buoh by Estudi Ribaudí



Lotus by Estudi Ribaudí



Mute by Nahtrang



Han by GoulaFiguera







Nutcreatives



Cristopher F. Wagner



Goula/Figuera



Xjer Studio



Alegre Design



Héctor Serrano



Àlex & Manel Llusçà



Andreu Carulla



Faro Lab



Conillas



Jordi Llopis



Bohman&Folenius



Nahtrang



Ernest Perera Studio



Lucid

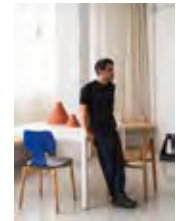

Isaac Piñeiro



Estudi Ribaudí



Jordi Busquets



Jordi Blasi



Pepe Llaudet



Roger Vancells



Adolfo Abejón



Aldanondoyfdez



Yembarastudio



Marina Milà



Cristina Borràs

DESIGNERS  
ARTISTS  
CREATORS

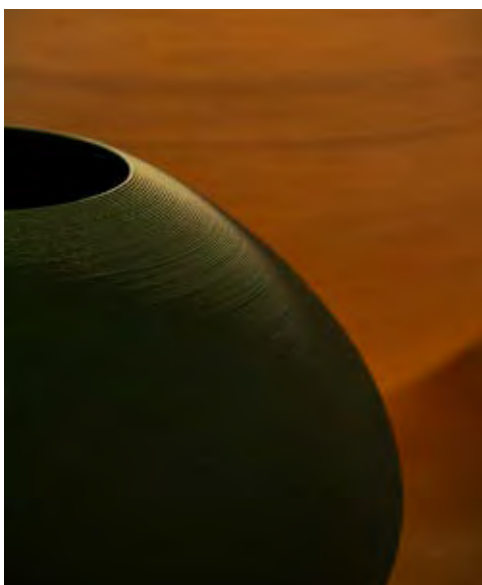

They make our world a better place thanks to their ingenuity, talent and creativity.

Espacio Princesa  
Princesa 52 Barcelona



The creativity, ingenuity and design of Faro Barcelona can be found in the heart of the city. Welcome to Espacio Princesa!

Request visit



Docontract MAD  
Velázquez 35-4ºD Madrid



This innovative space has emerged with the purpose of simplifying the work of architects, interior designers and developers looking for solutions for their new construction or renovation projects.

Showroom París  
7 Rue d'Uzès Paris



A space in which to carry out commercial activities such as visits, product demonstrations and meetings, and to develop a calendar of scheduled events to experience first-hand the design concept in lighting and ceiling fans.

## SHOWROOMS

We planned it to be the meeting point for designers, interior designers, architects and creatives to share their concerns and create a whole experience.

At Faro Barcelona, we control the quality of our products and services from conception and design to functionality and reliability tests.

Our quality management system is based on ISO9001.

Compliance with electrical safety regulations under EN60598 and energy efficiency ERP.

**Parametrical Lab**

Specification Compliance  
Electrical Safety Tests  
Integrating Sphere  
Climatic Chamber  
IK Tests

**Environmental Testing Lab**

Water IP Tests  
Powder IP Tests  
Salt Spray Chamber

**Technical Assistance Service (TAS)**

Customer Returns Analysis  
Customer Returns Repairs  
TAS Spare Parts

**Quality inspections Lab**

Batch inspections  
Functional Tests  
Product Assembly Control  
Product Finish Control

**Ceiling Fan Lab**

Life Test  
Customizations  
Airflow measurements  
Noise measurements

**Goniophotometer Room**



Q-LAB  
QUALITY & INNOVATION



Climatic Chamber



Goniophotometer Room



Integrating Sphere



# SERVICES



Assistance during installation

Consultancy and Advice

Product customisation

**Lighting projects**

Lighting calculations

Digital documentation: Dialux (ULD, IES, LDT) Revit / BIM (RFA) 3D files, IGS (SketchUp)

Advice on product selection

Lighting and fan projects department

Incident management

**Technical service**

Technical support service

**Custom & Special developments**



Special



Aire  
54



Mar  
52



Tierra  
50

Portable



Buddy  
66



Fuji  
60

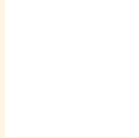

Serie  
pagina

Table



Amelia  
98



Akane  
132



Anouk  
114



Artis  
148



Banker  
120



Baobab  
120



Berni  
160



Bliss  
112



Conga  
140

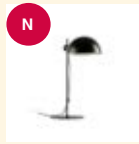

Dominica  
76



Drum  
134



Eterna  
110



Gru  
120



Guadalupe  
122



Hoshi  
102



Inviting  
100



Levita  
124

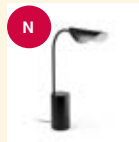

Liggera  
94



Linda  
154



Link  
130

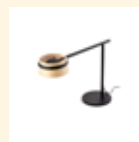

Loop  
126



Luang  
92



Lula  
108



Lupe  
156



Mambo  
136

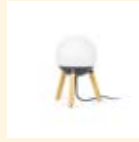

Mine  
106



Moma  
170



Montreal  
142

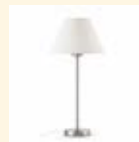

Nidia  
112

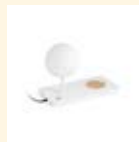

Niko  
104



Nila  
150



Otto  
116



Rem  
146



Samba  
138



Savoy  
144



Shan  
96



Stood  
128

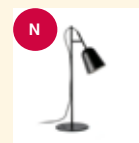

Studio  
72



Sweet  
172

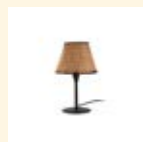

Sumba  
110



Tatawin  
80

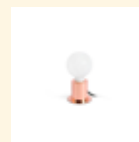

Ten  
102



Tree  
158



Venice  
84



Vesper  
152



Volta  
164

Clip



**Inviting**  
100



**Inviting**  
350



**Pepper**  
432

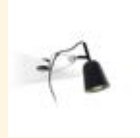

**Studio**  
430

Floor



**Artis**  
148



**Akane**  
132



**Berni**  
160



**Black**  
174



**Conga**  
140

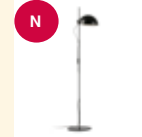

**Dominica**  
76



**Drum**  
134



**Guadalupe**  
122



**Guest**  
168



**Hotel**  
162



**Levita**  
124

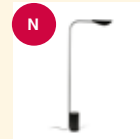

**Liggera**  
94



**Linda**  
154



**Link**  
130



**Loop**  
126



**Luang**  
92

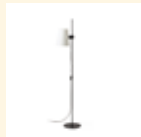

**Lupe**  
156



**Mambo**  
136



**Moma**  
170

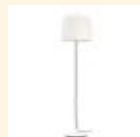

**Montreal**  
142



**Nila**  
150



**Papua**  
174



**Rem**  
146



**Samba**  
138



**Savoy**  
144



**Stand Up**  
166



**Stood**  
128

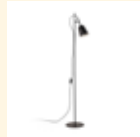

**Studio**  
72



**Sweet**  
172

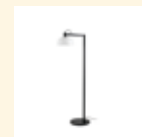

**Tatawin**  
80



**Tree**  
158



**Treewood**  
86



**Vesper**  
152



**Volta**  
164



**Venice**  
84

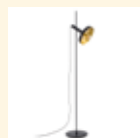

**Whizz**  
166

Surface



**Board**  
478



**Celia**  
470



**Chera**  
486



**Confetti**  
347



**Costas**  
358



**Cotton**  
460



**Diula**  
496



**Dominica**  
328



**Eaco**  
488



**Elsa**  
490



**Eres**  
454



**Han**  
368



**Homs**  
466



**Hudson**  
468



**Kamen**  
492



**Kera**  
466



**Levita**  
362



**Liggera**  
336



**Linda**  
474

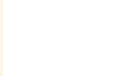

**Serie  
pagina**



**Loa**  
468



**Loop**  
378



**Luang**  
340



**Luna**  
492



**Magritte**  
494



**Serie  
pagina**



**May**  
360



**Milo**  
334



**Moy**  
362



**Nash**  
482



**Nila**  
342



**Noon**  
448



**Olaf**  
484



**Oslo**  
484



**Otton**  
456



**Ovo**  
454



**Ras**  
472



**Retro**  
474



**Roda**  
414



**Sahara**  
414



**Sera**  
466



**Snap**  
472



**Snow**  
490



**Stan**  
480



**Stood**  
376



**Studio**  
324



**Tatawin**  
332



**Ten**  
464



**Serie  
pagina**



**Venice**  
354



**Volga**  
504



**Whizz**  
366

Reader



**Artis**  
390



**Aurea**  
422



**Berni**  
408

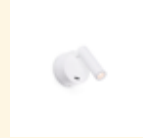

**Boc**  
428



**Conga**  
384

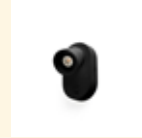

**Corb**  
452



**Duas**  
420



**Eterna**  
392



**Flin**  
428



**Fold**  
400



**Frame**  
396



**Guadalupe**  
370



**Handy**  
412



**Hotel**  
402

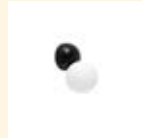

**Joy**  
362



**Juliet**  
434

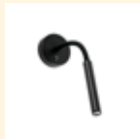

**Kale**  
436



**Le Petit**  
422



**Lead**  
440



**Loke**  
426



**Lupe**  
398



**Magos**  
364



**Mambo**  
388



**Moma**  
416



**Montreal**  
382

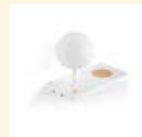

**Niko**  
372

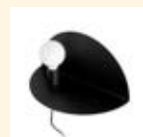

**Nit**  
450

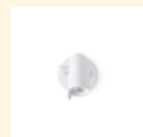

**Orleans**  
518



**Pixie**  
442



**Rem**  
394



**Rob**  
424



**Room**  
404



**Samba**  
380

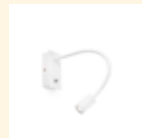

**Sami**  
438



**Savoy**  
382



**Smile**  
448



N

**Stan**  
418



**Suau**  
444



**Sumba**  
386



**Sweet**  
410



**Tila**  
448



**Tira**  
414



**Vesper**  
406



**Well**  
452



**Bath**



**Bianca**  
498

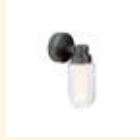

**Brume**  
498



**Danubio**  
00

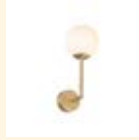

**Gala**  
500

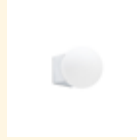

**Lago**  
502

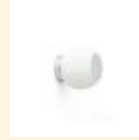

**Moy**  
362



**Nilo**  
506



**Perla**  
498

**Ceiling**

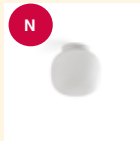

**Amelia**  
284



**Cocotte**  
292



**Janet**  
306



**Link**  
294



**Natsu**  
304



**Orleans**  
294



**Pote**  
308



**Rel**  
302



**Seven**  
310



**Shoku**  
286



**Stan**  
306



**Sven**  
300



**Tecto**  
296

**Bath**  
Baño



**Foro**  
314



**Kao**  
312



**Logos**  
316



**Tola**  
318

Suspended



**Art**  
252



**Charlotte**  
250



**Claire**  
262



**Clara**  
256



**Cocotte**  
220



**Confetti**  
198



**Conga**  
240



**Cosmos**  
268



**Costas**  
228



**Crater**  
248



**Danka**  
00



**Haka**  
232



**Halita**  
258



**Hotel**  
246

N



**Isabelle**  
182



**Kombo**  
222



**Lang**  
262



**Levita**  
208



**Liana**  
264

N



**Liggera**  
196



**Linda**  
246



**Lou**  
262



**Magma**  
248



**Mambo**  
236



**Margot**  
250



**Marina**  
260



**Marlin**  
258



**Mine**  
210



**Mou**  
256



**Naos**  
224



**Nido**  
264



**Ora**  
266



**Pam**  
270



**Plat**  
260



**Retro**  
206



**Rose**  
254



**Sabi**  
266



**Saigon**  
202



**Saipan**  
230



**Samba**  
238



**Savoy**  
242



**Seven**  
272



**Side**  
226



**Stan**  
266



**Stood**  
204

N



**Studio**  
178

N



**Tatawin**  
184



**Sumba**  
230



**Tree**  
246



**Tupai**  
230

N



**Venice**  
192



**Vesper**  
244



**Vico**  
200

N



**Whizz**  
194

**Spot**



**Coco**  
514



**Link**  
520



**Orleans**  
518



**Ring**  
520



**Stan**  
512



**Stone**  
516

**Recessed**



**Argón**  
540



**Clear**  
548



**Click**  
546



**Ebba**  
550



**Fox**  
552



**Fresh**  
556



**Gas**  
542



**Hyde**  
532



**Koi**  
544



**Loke**  
426



**Moist**  
550



**Nais**  
544



**Navi**  
524



**Neon**  
542



**Neu**  
526



**Nord**  
526



**Plas**  
530



**Radón**  
538



**Radón**  
538



**Radón**  
538



**Stan**  
550



**Suau**  
444



**Wabi**  
548



**Wet**  
548

**Track**



**Link**  
564



**Plot**  
564



**Stan**  
566





Portables



**Argus**  
598



**Balda**  
606



**Brot**  
630



**Candela**  
592



**Kasp**  
596



**Kerala**  
598



**Saigon**  
602

N



**Saigon**  
802



**Task**  
604



**Toc**  
600



**Versus**  
626



**Voila**  
606

Post



**Block**  
644



**Blubs**  
669



**Datna**  
652



**Giza**  
658



**Mauren**  
678



**Mila**  
674



**Mistu**  
668



**Moon**  
669



**Muffin**  
668



**Nala**  
674



**Naya**  
686



**Rush**  
702



**Screen**  
710



**Twist**  
648



**Wilma**  
660

Pole



**Beret**  
662



**Blubs**  
728



**Bu-Oh**  
718



**Mistu**  
724



**Muffin**  
726



**Nautica**  
730



**Plaza**  
720



**Rush**  
706



**Screen**  
714

Floor



**Akane**  
622



**Saigon**  
614



**Toc**  
600

Suspended



**Blubs**  
814



**Mistu**  
815



**Moon**  
815



**Muffin**  
814



**Nautica**  
816



**Saigon**  
798



**Scuba**  
810

N



**Scuba L**  
892

N

Recessed



**Crosby**  
956



**Dang**  
968



**Esca**  
976

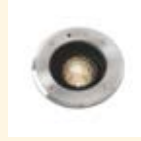

**Geiser**  
945



**Grund**  
950



**Kane**  
954



**Geiser**  
945



**Liso**  
976



**Salt**  
960



**Sedna**  
972



**Soun**  
970



**Spark**  
968



**Stripe 2**  
974



**Suria**  
958



**Taro**  
962



**Tecno**  
962



**Salt**  
960

Recessed  
Submersible



**Edel**  
966



**Nok**  
964

N

Surface



**Aday**  
910



**Ancora**  
898



**Argot**  
860



**Balic**  
832



**Blind**  
918



**Block**  
844



**Blubs**  
858



**Bonn**  
878



**Borda**  
868



**Bronx**  
836



**Bruc**  
914



**Bu-Oh**  
890



**Cabo**  
868



**Canon**  
916



**Cela**  
886



**Dado**  
860



**Doro**  
904



**Ele**  
924



**Estay**  
888



**Fedón**  
886



**Fred**  
00



**Future**  
894



**Gina**  
922



**Grant**  
938



**Hikari**  
876



**Keenan**  
936



**Kila**  
850



**Klamp**  
930



**Kubick**  
876



**Lace**  
914



**Lacre**  
916



**Lako**  
906



**Ling**  
914



**Log**  
918



**Loth**  
934



**Lotus**  
892



**Lur**  
876



**Mask**  
846



**Mistu**  
854



**Mol**  
882



**Moon**  
854





**Muffin**  
856



**Nahir**  
868



**Nala**  
870



**Natron**  
880



**Nautica**  
862



**Negus**  
878



**Noray**  
866



**Olan**  
918



**Oval**  
902



**Pals**  
834



**Pivot**  
872



**Pol**  
884

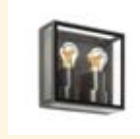

**Pomo**  
872



**Proa**  
926



**Path**  
938



**Pill**  
932



**Scuba**  
840



**Scuba**  
841



**Steps**  
928



**Sun**  
874



**Sunset**  
920



**Takua**  
900



**Tamashi**  
870



**Tejo**  
880



**Timon**  
866



**Tinia**  
922



**Tom**  
874



**Tond**  
908



**Twist**  
848



**View**  
894

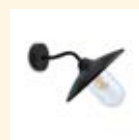

**Wally**  
864



**West**  
912



**Wilma**  
852

**Bollards**



**Agra**  
688



**Balic**  
640



**Beret**  
662



**Block**  
644



**Brot**  
628



**Blubs**  
671



**Bu-Oh**  
682



**Cast**  
646



**Cuca**  
768



**Das**  
684



**Datna**  
652



**Gina**  
690



**Giza**  
658



**Kila**  
654



**Klamp**  
692



**Logar**  
664



**Lotus**  
642



**Mistu**  
670

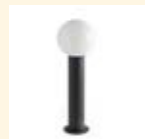

**Moon**  
671



**Muffin**  
670



**Onze**  
690



**Plim**  
656



**Rush**  
704



**Saura**  
694



**Screen**  
712



**Soleil**  
694



**Totem**  
638



**Tram**  
650



**Twist**  
648



**Wilma**  
660

**Projectors**



**Alfa**  
748

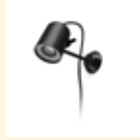

**Flow**  
752



**Lit**  
750



**Muur**  
744



**Noboru**  
672



**Plom**  
750

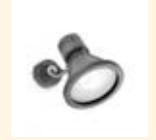

**Project**  
746



**Slot**  
756

**Spikes**



**Andy**  
790



**Bambou**  
782



**Clap**  
764



**Cuca**  
768

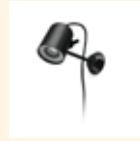

**Flow**  
752



**Piccola**  
778



**Plom**  
790



**Saigon**  
776



**Seth**  
786

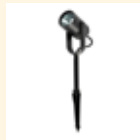

**Slot**  
758



**Sobek**  
788

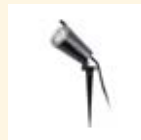

**Toni**  
780

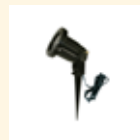

**Tono**  
792

**Ceiling**



**Dakron**  
828



**Goz**  
820



**Kila**  
824



**Mauren**  
678



**Olot**  
822

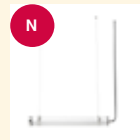

**Scuba**  
808



**Tami**  
820



**Tasa**  
822



**Yen**  
828

Tracklights



**Blit Track**  
1225



**Fost Track**  
1213



**Target**  
1201



**Via Track**  
1233

Downlights



**Backlight**  
1329



**Colin**  
1296



**Croc**  
1319

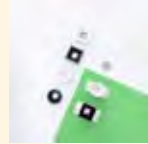

**Deep**  
1267

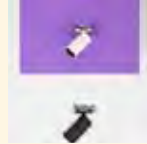

**Fost Recessed**  
1337



**Fost Pullwown**  
1347



**Kobo**  
1249



**Kope**  
1251



**Optic**  
1311



**Podium**  
1391

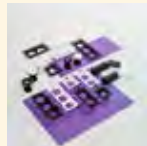

**Teide**  
1367

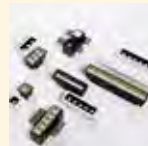

**Troop**  
1283

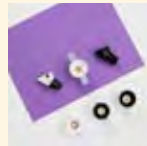

**Tulipa**  
1379



**Uno**  
1357

Surface



**Domio**  
1407



**Fost Ceilling**  
1437



**Podium Surface**  
1447



**Proofline**  
1429



**Scuba**  
1419

Suspended



**Fost Pendant**  
1471



**Mute**  
1461

Systems



**Fonovia**  
1543

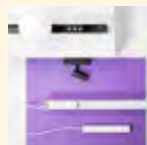

**Neso**  
1490

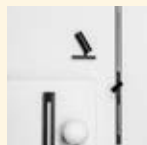

**Neso Slim**  
1504



**Via Evo**  
1519

Ledstrip



**Ledstrip**  
1555







TIERRA  
MAR &  
AIRE

by Héctor Serrano

*designed by Héctor Serrano*

**How did the project come about?**

Tierra, Mar and Aire (Earth, Sea and Air) arose from a concern about or interest in two concepts. First, an intention to democratise 3D printing on a large scale by integrating it as another industrial process in light manufacturing. Second, and most importantly, an interest in producing increasingly sustainable products and contributing to circularity. The project is something of a rallying cry encouraging us to consider our relationship with the planet in response to the current climate crisis. Nature does not generate waste: we must learn from it and move towards a more circular and sustainable product.









### **How would you describe the project?**

#### **What does it consist of?**

#### **What is the inspiration?**

The project is organised into three areas: Tierra, Mar and Aire. These are the elements that represent our planet and refer to the origins of the materials from which the lights are made.

The shape of each light is inspired by shapes found in nature as a tribute and to emphasise the respect we should have for nature.

Although each of the collections is independent and entirely visually different due to the materials, they share three essential design features:

#### **Calm:**

These are simple, appealing and timeless shapes that are easy to live with and allow the details of the material to be appreciated.

#### **Honest:**

We avoid adding more elements so we can appreciate and value the nature of the 3D printing process with the grooves. Also, there is no post-processing involving filling or lacquering for sustainability, i.e., the final piece is as it comes out of the machine.

#### **Organic and versatile:**

By not using moulds, we offer shape variations for a more organic language adaptable to architectural needs.



*“Nature does not generate waste: we must learn from it and move towards a more circular and sustainable production.”*

**Tierra 470**  
Héctor Serrano



20400 ● ● Black + Natural

**Tierra 500**  
Héctor Serrano



20401 ● ● Black + Natural

**Tierra 520**  
Héctor Serrano



20402 ● ● Black + Natural

<b>Material</b>	<b>Body Steel</b>
	<b>Shade PLA+Pine cellulose</b>
<b>Light Source</b>	1 E27 max. 18W
<b>Bulb incl.</b>	No
<b>Class</b>	II
<b>Voltage (V/Hz)</b>	100V-240V/50-60Hz
<b>Cable</b>	2 MT

<b>Material</b>	<b>Body Steel</b>
	<b>Shade PLA+Pine cellulose</b>
<b>Light Source</b>	1 E27 max. 18W
<b>Bulb incl.</b>	No
<b>Class</b>	II
<b>Voltage (V/Hz)</b>	100V-240V/50-60Hz
<b>Cable</b>	2 MT

<b>Material</b>	<b>Body Steel</b>
	<b>Shade PLA+Pine cellulose</b>
<b>Light Source</b>	1 E27 max. 18W
<b>Bulb incl.</b>	No
<b>Class</b>	II
<b>Voltage (V/Hz)</b>	100V-240V/50-60Hz
<b>Cable</b>	2 MT

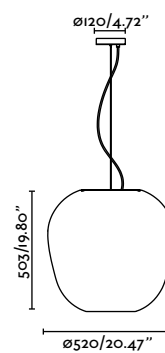
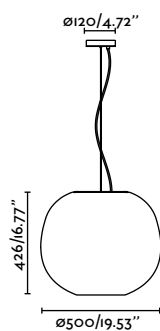
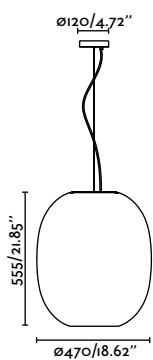

indoor

Tierra, Mar y Aire

# Tierra

Designed by Héctor Serrano

Its natural and imperfect texture provides a unique warmth.





**Mar H260**  
Héctor Serrano



20403 ●● Black + Green

**Mar H290**  
Héctor Serrano



20404 ●● Black + Green

**Mar H340**  
Héctor Serrano



20405 ●● Black + Green

<b>Material</b>	<b>Body</b> Steel
	<b>Shade</b> Recycled fishing net
<b>Light Source</b>	1 E27 max. 15W
<b>Bulb incl.</b>	No
<b>Class</b>	II
<b>Voltage (V/Hz)</b>	100V-240V/50-60Hz
<b>Cable</b>	2 MT

<b>Material</b>	<b>Body</b> Steel
	<b>Shade</b> Recycled fishing net
<b>Light Source</b>	1 E27 max. 15W
<b>Bulb incl.</b>	No
<b>Class</b>	II
<b>Voltage (V/Hz)</b>	100V-240V/50-60Hz
<b>Cable</b>	2 MT

<b>Material</b>	<b>Body</b> Steel
	<b>Shade</b> Recycled fishing net
<b>Light Source</b>	1 E27 max. 15W
<b>Bulb incl.</b>	No
<b>Class</b>	II
<b>Voltage (V/Hz)</b>	100V-240V/50-60Hz
<b>Cable</b>	2 MT

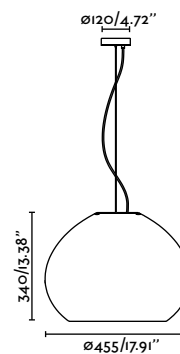
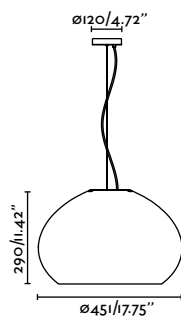
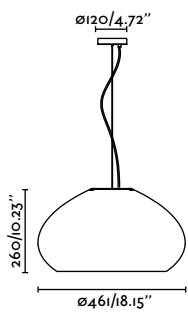

indoor

Tierra, Mar y Aire

# Mar

**Designed by** Héctor Serrano

Inspired by sea urchins,  
these luminaries are  
the result of the fusion  
of nature and 3D  
technology



**Aire 450**  
Héctor Serrano



20406

●● White + Translucent

**Aire 650**  
Héctor Serrano



20407

●● White + Translucent

**Aire 850**  
Héctor Serrano



20408

●● White + Translucent

<b>Material</b>	<b>Body</b> Steel
	<b>Shade</b> Recycled PETG
<b>Light Source</b>	1 E27 max. 15W
<b>Bulb incl.</b>	No
<b>Class</b>	II
<b>Voltage (V/Hz)</b>	100V-240V/50-60Hz
<b>Cable</b>	3 MT

<b>Material</b>	<b>Body</b> Steel
	<b>Shade</b> Recycled PETG
<b>Light Source</b>	1 E27 max. 20W
<b>Bulb incl.</b>	No
<b>Class</b>	II
<b>Voltage (V/Hz)</b>	100V-240V/50-60Hz
<b>Cable</b>	3 MT

<b>Material</b>	<b>Body</b> Steel
	<b>Shade</b> Recycled PETG
<b>Light Source</b>	1 E27 max. 18W
<b>Bulb incl.</b>	No
<b>Class</b>	II
<b>Voltage (V/Hz)</b>	100V-240V/50-60Hz
<b>Cable</b>	3 MT

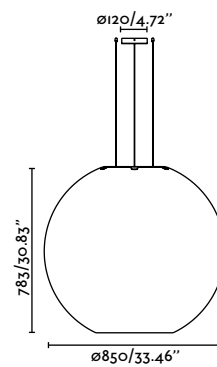
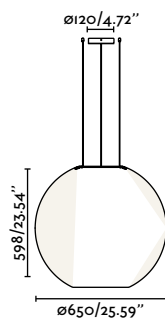
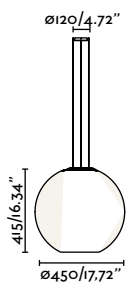

# Aire

Designed by Héctor Serrano

Its crystalline texture and appearance magically diffuse light through the shade of the lamp.









**INDOOR**

**LIGHTING**

# **PORTABLES**



Thanks to YSLA Architects | Photo by Munetaka Ondera

# Fuji

Designed by Isaac Piñeiro

Fuji is chameleonic.  
It adapts to your  
everyday life.



25cm



45cm



90cm



It works as portable, table  
and suspension lamp  
thanks to its hook.



reddot winner 2021



GERMAN  
DESIGN  
AWARD  
WINNER  
2022

**Fuji**  
Isaac Piñeiro

IP44 IK04 DIM 



74465

● Satin Black

<b>Material</b>	<b>Body</b> Aluminium+PC
	<b>Diff</b> Opal White PC
	<b>Shade</b> Aluminium
<b>Power</b>	1,5W
<b>Lumen Output</b>	90lm
<b>Light Source</b>	SMD LED 2700K
<b>Dimmable W</b>	0.5w 25lm / 1w 45lm / 1.5w 90lm
<b>Class</b>	III
<b>CRI</b>	>80
<b>Voltage (V/Hz)</b>	5V DC
<b>Battery incl.</b>	Yes
	6h Charge Max. 10h Worktime

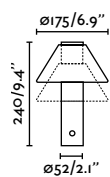





**Take Away**  
Nahtrng



- 01015  Matt White
- 01016  Matt Black

<b>Material</b>	<b>Body</b> ABS+Wood <b>Diff</b> White TPU
<b>Power</b>	1,5W
<b>Lumen Output</b>	100lm
<b>Light Source</b>	COB LED 2700K
<b>Dimmable W</b>	0,5w 30lm / 1w 55lm / 1,5w 100lm
<b>Class</b>	III
<b>CRI</b>	>80
<b>Voltage (V/Hz)</b>	5V DC
<b>Battery incl.</b>	Yes
	5h Charge Max. 5h Worktime



**Take Away accessory**

- 01017  Beech

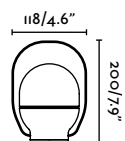

# Take Away

Designed by Nahtrang



Its wooden accessory allows you to fix it to the wall.



30lm



55lm



100lm

Take Away follows you wherever you go.





# Buddy

Designed by Andreu Carulla

Freedom  
and dynamism.  
No wires, no limits.



Touch switch offering three  
types of light: up, down and  
both sides.



**Buddy**  
Andreu Carulla



- 20210  Opal White + Green
- 20209  Opal White + Blue
- 20208  Opal White + Dark Grey



<b>Material</b>	<b>Body</b> PC
	<b>Diff</b> Opal PC
	<b>Shade</b> PC
<b>Power</b>	3W
<b>Lumen Output</b>	260lm
<b>Light Source</b>	SMD LED 2700K
<b>Class</b>	III
<b>CRI</b>	>80
<b>Voltage (V/Hz)</b>	5V DC
<b>Battery incl.</b>	Yes
	9h Charge Max. Max. 10h Worktime

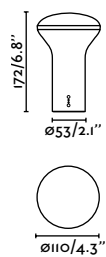







# TABLE & FLOOR



Studio floor Ref. 28272

70

# Studio NEW

Designed by Nahtrang

Studio brings back lines of the 1950s and reinterprets them to fit into a modern context.



The main feature of its design that makes it unique is the way the cable is attached to the structure.



Studio table Ref. 28252



**Studio table**  
Nahtrang



- 28251 Matt Black + Black
- 28252 Matt Black + White
- 28253 Matt Black + Green
- 28269 Matt Black + Blue
- 28270 Matt Black + Pink

<b>Material</b>	<b>Body</b> Steel
	<b>Shade</b> Steel
<b>Light Source</b>	1 E14 max. 8W
<b>Bulb incl.</b>	No
<b>Class</b>	II
<b>Voltage (V/Hz)</b>	100V-240V/50-60Hz
<b>Cable</b>	1.8 MT

**Studio floor**  
Nahtrang



- 28254 Matt Black + Black
- 28255 Matt Black + White
- 28256 Matt Black + Green
- 28271 Matt Black + Blue
- 28272 Matt Black + Pink

<b>Material</b>	<b>Body</b> Steel
	<b>Shade</b> Steel
<b>Light Source</b>	1 E14 max. 8W
<b>Bulb incl.</b>	No
<b>Class</b>	II
<b>Voltage (V/Hz)</b>	100V-240V/50-60Hz
<b>Cable</b>	2.3 MT



**Suspended**  
178



**Wall**  
324

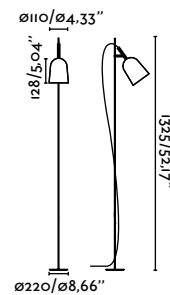
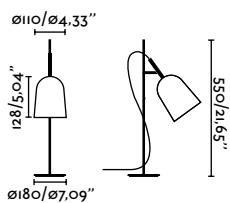



# Dominica NEW

Designed by Faro Lab

Its design of simple and friendly geometric shapes contrasts with its sober and industrial style.



Its shade is adjustable on the horizontal plane.



Dominica table Ref. 20033-122





**Dominica table**  
Faro Lab



- 20033-122 Matt Black + Beige
- 20033-123 Matt Black + Matt Black

<b>Material</b>	<b>Body</b> Steel
	<b>Shade</b> Steel
<b>Light Source</b>	1 E27 max. 15W
<b>Bulb incl.</b>	No
<b>Class</b>	II
<b>Voltage (V/Hz)</b>	100V-240V/50-60Hz
<b>Cable</b>	1.5 MT

**Dominica floor**  
Faro Lab



- 20034-122 Matt Black + Beige
- 20034-123 Matt Black + Matt Black

<b>Material</b>	<b>Body</b> Steel
	<b>Shade</b> Steel
<b>Light Source</b>	1 E27 max. 15W
<b>Bulb incl.</b>	No
<b>Class</b>	II
<b>Voltage (V/Hz)</b>	100V-240V/50-60Hz
<b>Cable</b>	3.5 MT



Wall  
328

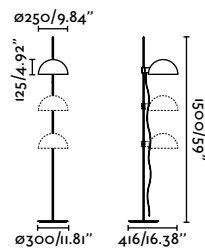
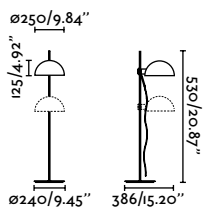







Tatawin table Ref. 20337-117

# Tatawin

**Designed by** Adolfo Abejón

Inspired by  
the houses of  
Tataouine, Tunisia.



Its blown glass shade provides  
nostalgia and warmth.

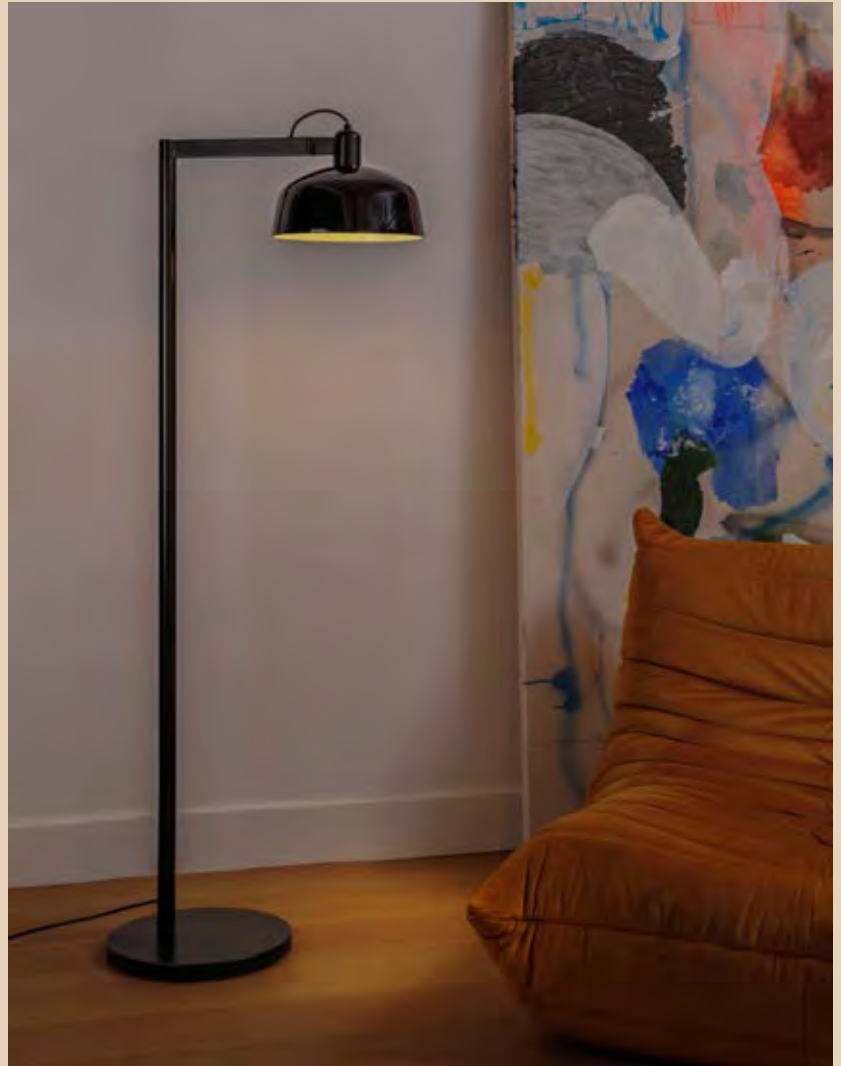

Tatawin floor Ref. 20336-120

**Tatawin table**  
Adolfo Abejón



- 20337-116 ●● Satin Black + Opal
- 20337-117 ●● Satin Black + Shiny Black

<b>Material</b>	<b>Body</b> Steel
	<b>Shade</b> Glass
<b>Light Source</b>	1 E27 G45 max. 15W
<b>Bulb incl.</b>	No
<b>Class</b>	II
<b>Voltage (V/Hz)</b>	100V-240V/50-60Hz
<b>Cable</b>	1.5 MT

**Tatawin floor**  
Adolfo Abejón



- 20336-119 ●● Satin Black + Opal
- 20336-120 ●● Satin Black + Shiny Black

<b>Material</b>	<b>Body</b> Steel
	<b>Shade</b> Glass
<b>Light Source</b>	1 E27 max. 15W
<b>Bulb incl.</b>	No
<b>Class</b>	II
<b>Voltage (V/Hz)</b>	100V-240V/50-60Hz
<b>Cable</b>	2 MT



**Suspended**  
186



**Wall**  
332

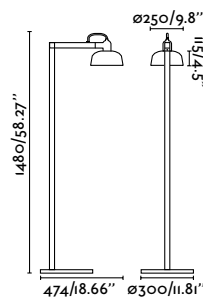
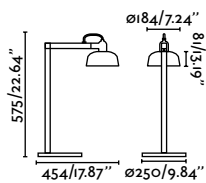





Tatawin table Ref. 20337-116





Venice floor Ref. 64275-111

# Venice

**Designed by** Adolfo Abejón

Designed and produced locally and handcrafted in Barcelona.



Following a traditional and manual process, the shade is produced by casting the ceramic.



Venice table Ref. 64276-113

**Venice table**  
Adolfo Abejón



- 64276-115 ●● Satin Black + Blue
- 64276-111 ●● Satin Black + White
- 64276-112 ●● Satin Black + Shiny Black
- 64276-114 ●||| Satin Black + Black & White Gloss
- 64276-113 ●● Satin Black + Pink

<b>Material</b>	<b>Body</b> Steel
	<b>Shade</b> Ceramic
<b>Light Source</b>	1 E27 max. 15W
<b>Bulb incl.</b>	No
<b>Class</b>	II
<b>Voltage (V/Hz)</b>	100V-240V/50-60Hz
<b>Cable</b>	1.5 MT

**Venice floor**  
Adolfo Abejón



- 64275-115 ●● Satin Black + Blue
- 64275-111 ●● Satin Black + White
- 64275-112 ●● Satin Black + Shiny Black
- 64275-114 ●||| Satin Black + Black & White Gloss
- 64275-113 ●● Satin Black + Pink

<b>Material</b>	<b>Body</b> Steel+Ceramic
	<b>Shade</b> Ceramic
<b>Light Source</b>	1 E27 max. 15W
<b>Bulb incl.</b>	No
<b>Class</b>	II
<b>Voltage (V/Hz)</b>	100V-240V/50-60Hz
<b>Cable</b>	2 MT



**Suspended**  
192



**Wall**  
354

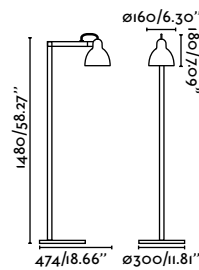
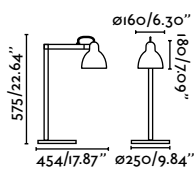



Venice table Ref. 64276-112

**Treewood**  
Faro Lab



20056

● Ash Tree + Beige

<b>Material</b>	<b>Body</b> Ash tree+Steel
	<b>Shade</b> Parchment
<b>Light Source</b>	1 E27 max. 15W
<b>Bulb incl.</b>	No
<b>Class</b>	II
<b>Voltage (V/Hz)</b>	100V-240V/50-60Hz
<b>Cable</b>	1.8 MT

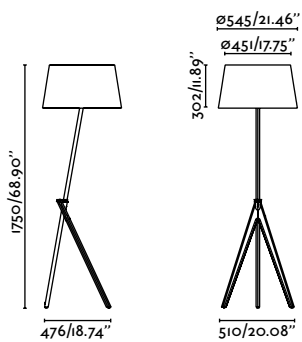

**Treewood Tray**  
Faro Lab



20057

● Ash Tree + Beige

<b>Material</b>	<b>Body</b> Ash tree+Steel
	<b>Shade</b> Parchment
<b>Light Source</b>	1 E27 max. 15W
<b>Bulb incl.</b>	No
<b>Class</b>	II
<b>Voltage (V/Hz)</b>	100V-240V/50-60Hz
<b>Cable</b>	1.8 MT

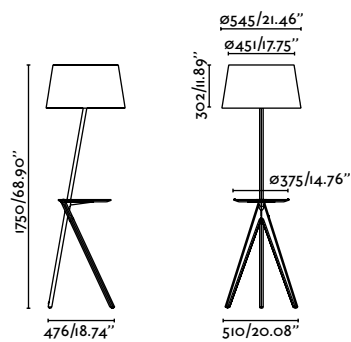



# Treewood NEW

Designed by Faro Lab

Its oak structure and parchment shade are reminiscent of the Scandinavian aesthetics of the 1950s.



# Luang

**Designed by** Faro Lab

Inspired by the Southeast Asian culture and its way of creating objects from paper art.



It is a design of proximity manufacturing: its structure is produced in Spain and its shade in Bulgaria.

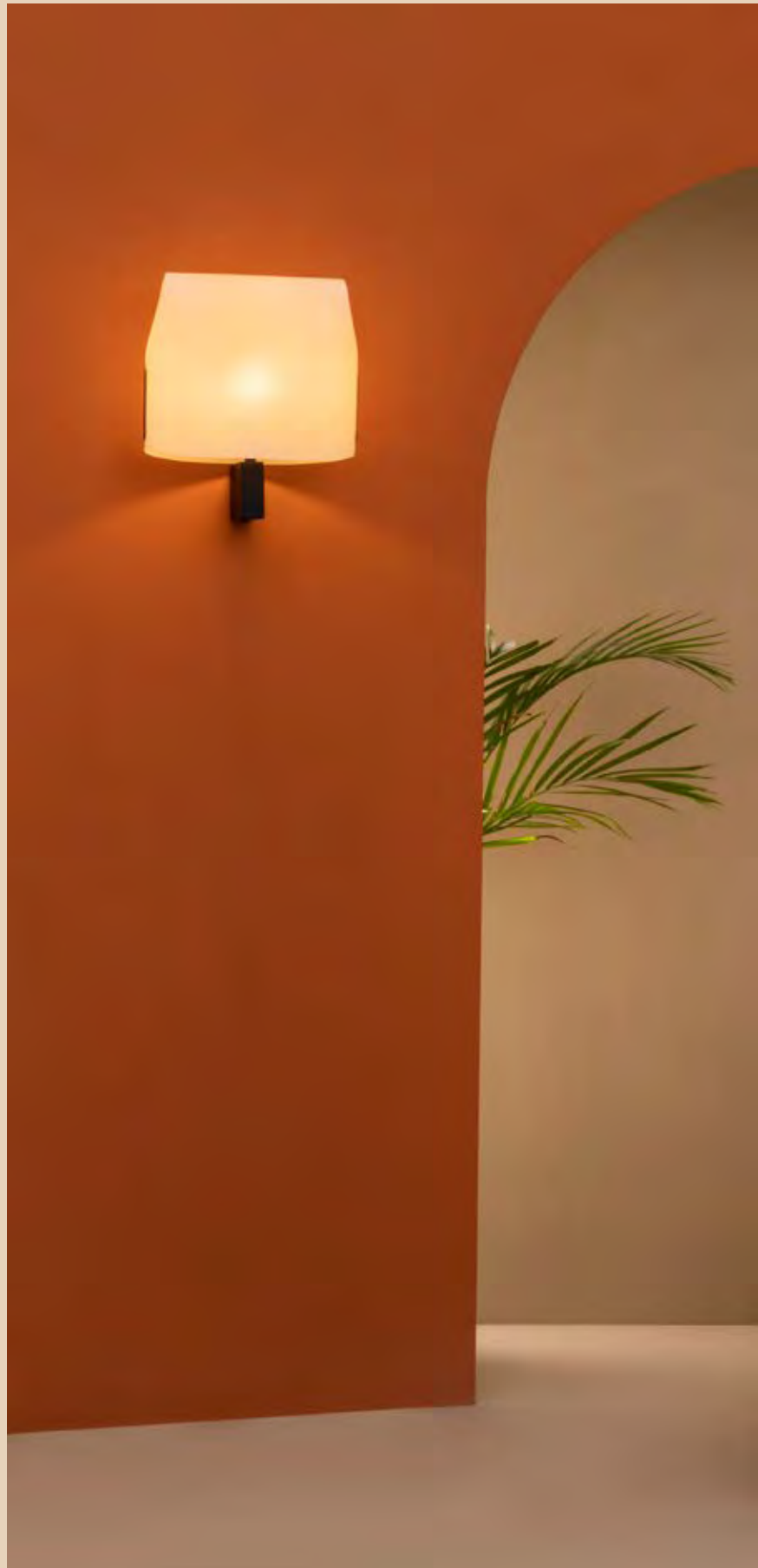



**Luang XS**  
Faro Lab



NEW



- 23065  Black + Beige
- 23066  Black + Camel

<b>Material</b>	<b>Body Steel</b>
	<b>Shade Parchment</b>
<b>Light Source</b>	E14 max. 8W
<b>Bulb incl.</b>	No
<b>Class</b>	II
<b>Voltage (V/Hz)</b>	100V-240V/50-60Hz
<b>Cable</b>	1.5 MT

**Luang table S**  
Faro Lab



- 23001-57  Black + Beige
- 23001-58  Black + Camel

<b>Material</b>	<b>Body Steel</b>
	<b>Shade Parchment</b>
<b>Light Source</b>	1 E27 max. 15W
<b>Bulb incl.</b>	No
<b>Class</b>	II
<b>Voltage (V/Hz)</b>	100V-240V/50-60Hz
<b>Cable</b>	1.9 MT



Wall  
340

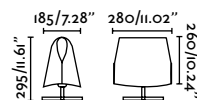
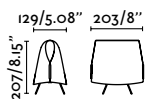





**Luang table M**  
Faro Lab



- 23002-57   Black + Beige
- 23002-58   Black + Camel

<b>Material</b>	<b>Body</b> Steel
	<b>Shade</b> Parchment
<b>Light Source</b>	1 E27 max. 15W
<b>Bulb incl.</b>	No
<b>Class</b>	II
<b>Voltage (V/Hz)</b>	100V-240V
<b>Cable</b>	1.9 MT

**Luang floor**  
Faro Lab



- 23003-59   Black + Beige
- 23003-60   Black + Camel

<b>Material</b>	<b>Body</b> Steel
	<b>Shade</b> Parchment
<b>Light Source</b>	1 E27 max. 15W
<b>Bulb incl.</b>	No
<b>Class</b>	II
<b>Voltage (V/Hz)</b>	100V-240V
<b>Cable</b>	1.8 MT



Wall  
340

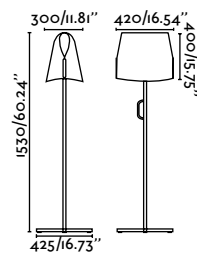
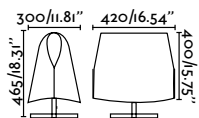



Luang floor Ref. 23003-60

## Liggera table

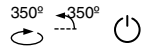

20076

●● Matt Black + Matt Black

<b>Material</b>	<b>Body</b> Steel
	<b>Shade</b> Steel
<b>Light Source</b>	1 G9 max. 6W
<b>Bulb incl.</b>	No
<b>Class</b>	II
<b>Voltage (V/Hz)</b>	100V-240V/50-60Hz
<b>Cable</b>	1.8 MT

## Liggera floor



20075

●● Matt Black + Matt Black

<b>Material</b>	<b>Body</b> Steel
	<b>Shade</b> Steel
<b>Light Source</b>	1 G9 max. 6W
<b>Bulb incl.</b>	No
<b>Class</b>	II
<b>Voltage (V/Hz)</b>	100V-240V/50-60Hz
<b>Cable</b>	2.2 MT



**Suspension**  
196



**Wall**  
336

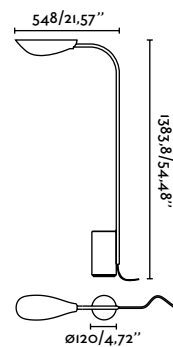
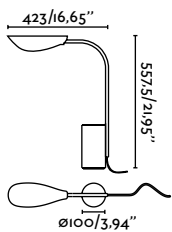

# Liggera



Liggera table Ref. 20076

Its aesthetic lightness adapts to any space in a natural way.

Its soft and natural forms are inspired by ancient Japanese minimalism.



Liggera floor Ref. 20075

**Shan**  
Pepe Llaudet



20069

● ● White + Beige

<b>Material</b>	<b>Body</b> Steel
	<b>Shade</b> Parchment
<b>Light Source</b>	1 E27 max. 15W
<b>Bulb incl.</b>	No
<b>Class</b>	II
<b>Voltage (V/Hz)</b>	100V-240V/50-60Hz
<b>Cable</b>	2.1 MT

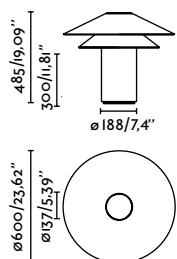



# Shan

NEW

Designed by Pepe Llaudet

Composed of three handmade parchment shades, its essence is inspired by the architecture and materials of Japanese Zen culture. Shan transcends time and fashion.



**Amelia table**  
Héctor Serrano



- 28430  Matt White
- 28431  Matt Black

<b>Material</b>	<b>Body Steel</b>
	<b>Diff Opal White Glass</b>
<b>Light Source</b>	E27 max. 15W
<b>Bulb incl.</b>	No
<b>Class</b>	II
<b>Voltage (V/Hz)</b>	100V-240V/50-60Hz
<b>Cable</b>	1.5 MT



**Ceiling**  
284

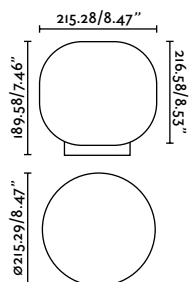

# Amelia NEW

Designed by Héctor Serrano

A calm lamp that blends into the space and uplifts it delicately all at once.



**Inviting**  
Bohman And Folenius



- 57315  Matt White
- 57316  Matt Black
- 57317  Yellow

<b>Material</b>	<b>Body</b> Aluminium
	<b>Diff</b> Transparent PMMA
<b>Power</b>	6W
<b>Lumen Output</b>	410lm
<b>Light Source</b>	SMD LED
<b>Dimmable K</b>	2700 - 4800K
<b>Class</b>	II
<b>CRI</b>	>80
<b>Voltage (V/Hz)</b>	100V-240V/50-60Hz
<b>Cable</b>	1.9 MT

**Inviting**  
Bohman And Folenius



- 57312  Matt White
- 57313  Black
- 57314  Yellow

<b>Material</b>	<b>Body</b> Aluminium+Steel
	<b>Diff</b> Transparent PMMA
<b>Power</b>	6W
<b>Lumen Output</b>	410lm
<b>Light Source</b>	SMD LED
<b>Dimmable K</b>	2700 - 4800K
<b>Class</b>	II
<b>CRI</b>	>80
<b>Voltage (V/Hz)</b>	100V-240V/50-60Hz
<b>Cable</b>	1.9 MT



Wall  
350

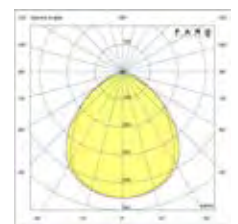
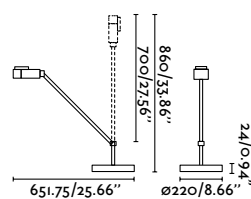
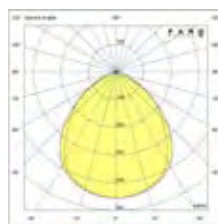
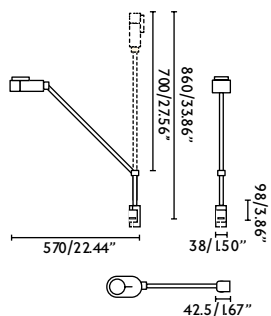

# Inviting

Designed by Bohman And Folenius

Ergonomic  
and human  
centred design.



Colour temperature and  
intensity can be easily adjusted.



reddot award 2019  
winner



GERMAN  
DESIGN  
AWARD  
SPECIAL  
2019



**Ten**  
Faro Lab



- 62156 Shiny Copper
- 62157 Satin Gold
- 62168 Matt White
- 62169 Matt Black

<b>Material</b>	Body Steel
<b>Light Source</b>	1 E27 max. 15W
<b>Bulb incl.</b>	No
<b>Class</b>	II
<b>Voltage (V/Hz)</b>	100V-240V/50-60Hz
<b>Cable</b>	1.5 MT

**Hoshi**  
Xjer Studio



- 28387 Satin Gold + Matt Black
- 28388 Black + Copper

<b>Material</b>	Body Steel
	Diff Opal PC
<b>Power</b>	12W
<b>Lumen Output</b>	930lm
<b>Light Source</b>	SMD LED 2700K
<b>Class</b>	II
<b>CRI</b>	>80
<b>Voltage (V/Hz)</b>	100V-240V/50-60Hz
<b>Cable</b>	2 MT



Wall  
464

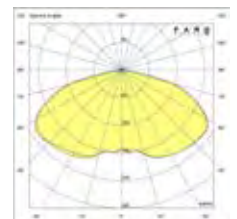
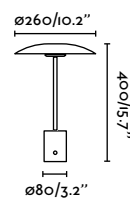
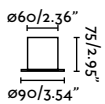

# Ten & Hoshi



Hoshi Ref. 28388



Ten Ref. 62169

**Niko PC**  
Nahtrang



01025A ● ● Matt White + Wood

<b>Material</b>	<b>Body</b> Aluminium+Wood
	<b>Diff</b> Opal PC
<b>Power</b>	7W
<b>Lumen Output</b>	500lm
<b>Light Source</b>	SMD LED 3000K
<b>Dimmable W</b>	1w 80lm / 4w 250lm / 7w 500lm
<b>Class</b>	II
<b>CRI</b>	>80
<b>Voltage (V/Hz)</b>	100V-240V/50-60Hz

**Niko Glass**  
Nahtrang



01007A ● ● Matt White + Wood

<b>Material</b>	<b>Body</b> Aluminium+Wood
	<b>Diff</b> Opal Glass
<b>Power</b>	7W
<b>Lumen Output</b>	500lm
<b>Light Source</b>	SMD LED 3000K
<b>Dimmable W</b>	1w 80lm / 4w 250lm / 7w 500lm
<b>Class</b>	II
<b>CRI</b>	>80
<b>Voltage (V/Hz)</b>	100V-240V/50-60Hz



Wall  
372

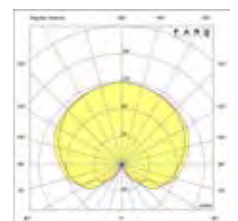
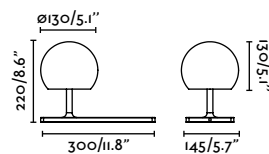
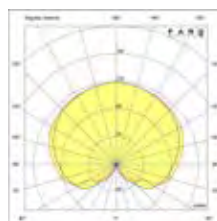
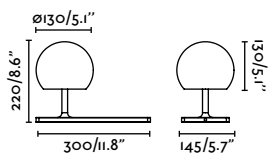

# Niko

Designed by Nahtrang



its structure has a wooden  
induction charger without cables  
and a USB port.

**Mine PC**  
Nahtrang



- 28211   Matt White + Wood
- 28212   Dark Grey + Wood

<b>Material</b>	<b>Body</b> Aluminium+Wood
	<b>Diff</b> Opal PC
<b>Light Source</b>	1 E27 max. 15W
<b>Bulb incl.</b>	No
<b>Class</b>	II
<b>Voltage (V/Hz)</b>	100V-240V/50-60Hz
<b>Cable</b>	1.8 MT

**Mine Glass**  
Nahtrang



- 28378   Matt White + Wood
- 28379   Dark Grey + Wood

<b>Material</b>	<b>Body</b> Aluminium+Wood
	<b>Diff</b> Opal Glass
<b>Light Source</b>	1 E27 max. 15W
<b>Bulb incl.</b>	No
<b>Class</b>	II
<b>Voltage (V/Hz)</b>	100V-240V/50-60Hz
<b>Cable</b>	1.8 MT



**Suspended**  
210

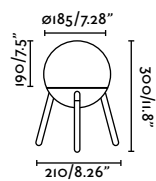
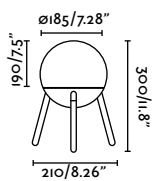



indoor

Table & Floor

# Mine

Designed by Nahtrang





**Lula S**  
Marina Milá



- 28380  Matt White + White
- 28382  Matt Black + White

<b>Material</b>	<b>Body</b> Steel
	<b>Shade</b> Textile
<b>Light Source</b>	1 E27 max. 15W
<b>Bulb incl.</b>	No
<b>Class</b>	II
<b>Voltage (V/Hz)</b>	100V-240V/50-60Hz
<b>Cable</b>	1.7 MT

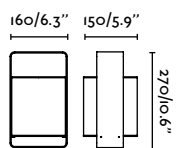

**Lula M**  
Marina Milá



- 28383  Matt White + White
- 28385  Matt Black + White

<b>Material</b>	<b>Body</b> Steel
	<b>Shade</b> Textile
<b>Light Source</b>	1 E27 max. 15W
<b>Bulb incl.</b>	No
<b>Class</b>	II
<b>Voltage (V/Hz)</b>	100V-240V/50-60Hz
<b>Cable</b>	1.7 MT

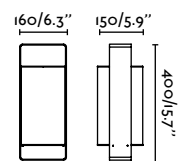

indoor

Table & Floor

# Lula

Designed by Marina Milá



**Eterna**  
Lucid Product Design



- 24008-13  Chrome + White
- 24008-14  Chrome + Beige
- 24008-15  Chrome + Black

<b>Material</b>	<b>Body</b> Steel
	<b>Shade</b> Textile
<b>Light Source</b>	1 E27 max. 15W
<b>Bulb incl.</b>	No
<b>Class</b>	II
<b>Voltage (V/Hz)</b>	100V-240V/50-60Hz
<b>Cable</b>	1.8 MT

**Sumba table S**  
Faro Lab



- 64317-71  Black + Rattan

<b>Material</b>	<b>Body</b> Steel
	<b>Shade</b> Rattan
<b>Light Source</b>	1 E27 max. 15W
<b>Bulb incl.</b>	No
<b>Class</b>	II
<b>Voltage (V/Hz)</b>	100V-240V/50-60Hz
<b>Cable</b>	1.5 MT



**Wall**  
392



**Suspended**  
230



**Wall**  
386

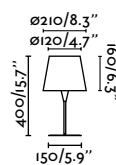
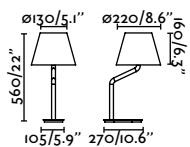

\*Structures and shades also sold separately 1408-1409

# Eterna & Sumba



Eterna Ref. 24008-14

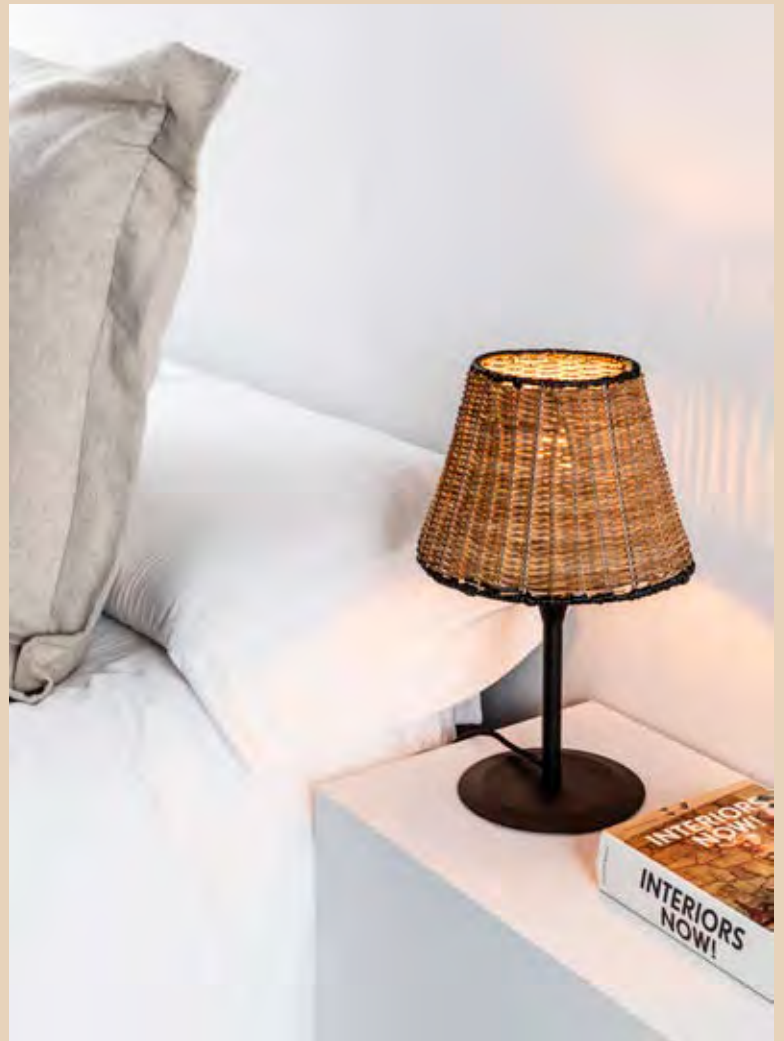

Sumba table S Ref. 64317-71



## Bliss



28401

● ● Ash Tree + White

<b>Material</b>	<b>Body</b> Wood
	<b>Shade</b> Textile
<b>Light Source</b>	1 E27 max. 15W
<b>Bulb incl.</b>	No
<b>Class</b>	II
<b>Voltage (V/Hz)</b>	100V-240V/50-60Hz
<b>Cable</b>	1.8 MT

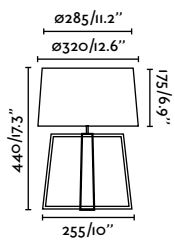

## Nidia



68423

● ● Satin Nickel + White

<b>Material</b>	<b>Body</b> Steel
	<b>Shade</b> Textile
<b>Light Source</b>	1 E27 max. 15W
<b>Bulb incl.</b>	No
<b>Class</b>	II
<b>Voltage (V/Hz)</b>	100V-240V/50-60Hz
<b>Cable</b>	1.8 MT

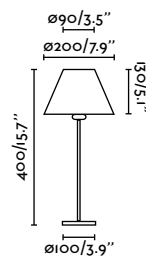

Bliss

indoor

Table & Floor



## Anouk



53415 ● Matt Black

<b>Material</b>	<b>Body ABS</b>
	<b>Diff Translucent PMMA</b>
<b>Power</b>	8W
<b>Lumen Output</b>	530lm
<b>Light Source</b>	SMD LED 4000K
<b>Class</b>	II
<b>CRI</b>	>80
<b>Voltage (V/Hz)</b>	100V-240V/50-60Hz
<b>Cable</b>	1.5 MT

## Anouk induction



53416 ● Shiny White

<b>Material</b>	<b>Body ABS</b>
	<b>Diff Translucent PMMA</b>
<b>Power</b>	8W
<b>Lumen Output</b>	607lm
<b>Light Source</b>	SMD LED
<b>Dimmable K</b>	2700 - 6500K
<b>Class</b>	II
<b>Voltage (V/Hz)</b>	100V-240V/50-60Hz

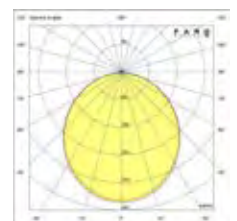
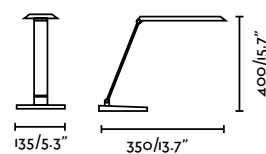
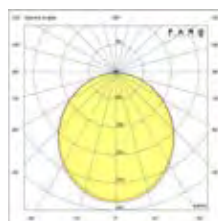
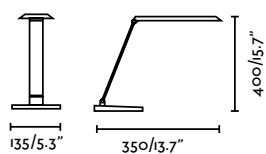



# Anouk

indoor

Table & Floor



# Otto



- 52065-110 ● Matt White
- 52064-110 ● Matt Black

<b>Material</b>	<b>Body</b> ABS+Silicone <b>Diff</b> Opal PMMA
<b>Power</b>	6W
<b>Lumen Output</b>	500lm
<b>Light Source</b>	SMD LED 4000K
<b>Class</b>	II
<b>CRI</b>	>80
<b>Voltage (V/Hz)</b>	110V/50-60Hz
<b>Cable</b>	1.8 MT

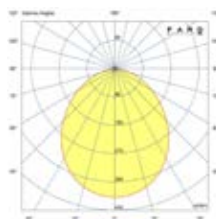
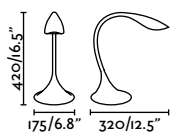



Otto

indoor

Table & Floor



**Snap**  
Faro Lab



57400

● White

57401

● Dark Grey

<b>Material</b>	Body Steel
<b>Light Source</b>	1 E27 max. 15W
<b>Bulb incl.</b>	No
<b>Class</b>	II
<b>Voltage (V/Hz)</b>	100V-240V/50-60Hz
<b>Cable</b>	1.8 MT



**Wall**  
472

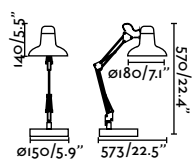

Snap

indoor

Table & Floor



**Banker**



**68334** Old Gold + Green

<b>Material</b>	<b>Body Steel</b>
	<b>Diff Glass</b>
<b>Light Source</b>	1 E27 max. 15W
<b>Bulb incl.</b>	No
<b>Class</b>	II
<b>Voltage (V/Hz)</b>	100V-240V/50-60Hz
<b>Cable</b>	1.9 MT

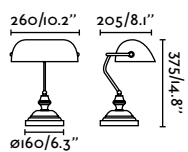

**Gru**



**51916** Matt White  
**51917** Matt Black

<b>Material</b>	<b>Body Steel</b>
<b>Light Source</b>	1 E27 max. 15W
<b>Bulb incl.</b>	No
<b>Class</b>	II
<b>Voltage (V/Hz)</b>	100V-240V/50-60Hz
<b>Cable</b>	1.7 MT

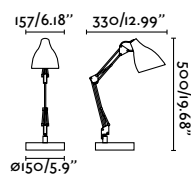

**Baobab**



**51908** Matt White  
**51909** Matt Black  
**51910** Grey

<b>Material</b>	<b>Body Steel</b>
<b>Light Source</b>	1 E14 max. 8W
<b>Bulb incl.</b>	No
<b>Class</b>	II
<b>Voltage (V/Hz)</b>	100V-240V/50-60Hz
<b>Cable</b>	1.7 MT

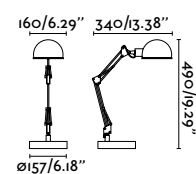



# Baobab

indoor

Table & Floor





**Guadalupe table**  
Faro Lab



- 20033-80  Matt Black + Beige
- 20033-81  Matt Black + Green

<b>Material</b>	<b>Body Steel</b>
	<b>Shade Steel</b>
<b>Light Source</b>	1 E27 max. 15W
<b>Bulb incl.</b>	No
<b>Class</b>	II
<b>Voltage (V/Hz)</b>	100V-240V/50-60Hz
<b>Cable</b>	1.5 MT

**Guadalupe floor**  
Faro Lab



- 20034-80  Matt Black + Beige
- 20034-81  Matt Black + Green

<b>Material</b>	<b>Body Steel</b>
	<b>Shade Steel</b>
<b>Light Source</b>	1 E27 max. 15W
<b>Bulb incl.</b>	No
<b>Class</b>	II
<b>Voltage (V/Hz)</b>	100V-240V/50-60Hz
<b>Cable</b>	3.5 MT



Wall  
370

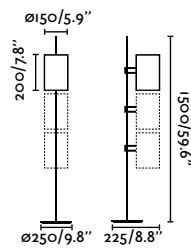
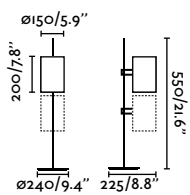

# Guadalupe

Designed by Faro Lab



Guadalupe table Ref. 20033-81

With a tube-shaped shade, it channels the light creating a theatrical effect.



Guadalupe floor Ref. 20034-80

**Levita table**  
Nahtrang

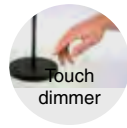

- 29692D-110 ● Shiny Gold
- 29697-110 ● Matt Black

<b>Material</b>	<b>Body Steel</b>
	<b>Diff Opal Glass</b>
<b>Power</b>	7W
<b>Lumen Output</b>	700lm
<b>Light Source</b>	SMD LED 2700K
<b>Dimmable W</b>	1w 95lm / 4w 380lm / 6w 570lm
<b>Class</b>	II
<b>CRI</b>	>80
<b>Voltage (V/Hz)</b>	110V/50-60Hz
<b>Cable</b>	2 MT

**Levita floor**  
Nahtrang

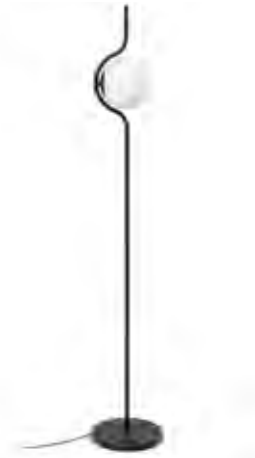

- 29693D ● Shiny Gold
- 29698 ● Matt Black

<b>Material</b>	<b>Body Steel</b>
	<b>Diff Opal Glass</b>
<b>Power</b>	7W
<b>Lumen Output</b>	700lm
<b>Light Source</b>	SMD LED 2700K
<b>Dimmable W</b>	1w 95lm / 4w 380lm / 6w 570lm
<b>Class</b>	II
<b>CRI</b>	>80
<b>Voltage (V/Hz)</b>	100V-240V/50-60Hz
<b>Cable</b>	2 MT



Wall  
362

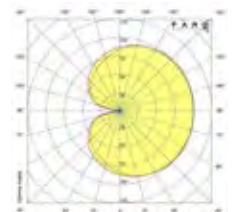
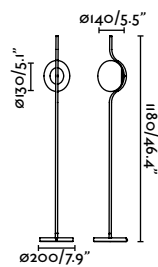
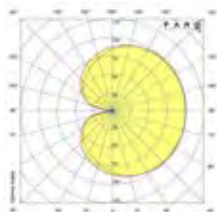
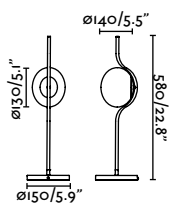

# Levita

Designed by Nahtrang



Levita table Ref. 29692D-110

Thanks to its glass diffuser, it offers a homogeneous and dim light, avoiding glare.



Le vita floor Ref. 29698

**Loop table**  
Estudi Ribaudí



- 29398-110   Matt Black + Ash Tree
- 29568-110   Matt Black + Cherry

<b>Material</b>	<b>Body Steel</b>
	<b>Diff Translucent PMMA</b>
	<b>Shade Wood</b>
<b>Power</b>	6W
<b>Lumen Output</b>	600lm
<b>Light Source</b>	SMD LED 2700K
<b>Dimmable W</b>	1w 100lm / 3w 300lm / 6w 600lm
<b>Class</b>	II
<b>CRI</b>	>80
<b>Voltage (V/Hz)</b>	110V/50-60Hz
<b>Cable</b>	2 MT

**Loop floor**  
Estudi Ribaudí



- 29399-110   Matt Black + Ash Tree
- 29569-110   Matt Black + Cherry

<b>Material</b>	<b>Body Steel</b>
	<b>Diff Translucent PMMA</b>
	<b>Shade Wood</b>
<b>Power</b>	6W
<b>Lumen Output</b>	600lm
<b>Light Source</b>	SMD LED 2700K
<b>Dimmable W</b>	1w 100lm / 3w 300lm / 6w 600lm
<b>Class</b>	II
<b>CRI</b>	>80
<b>Voltage (V/Hz)</b>	110V/50-60Hz
<b>Cable</b>	2 MT

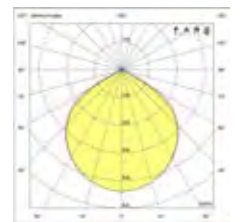
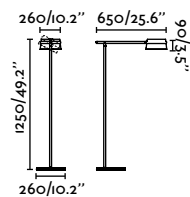
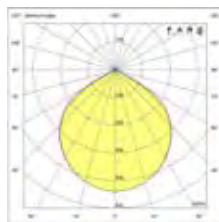
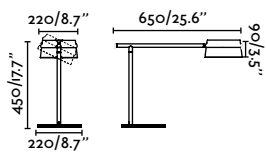



# Loop

Designed by Estudi Ribaudí



Natural laminated wood of American origin.



1W 100lm



3W 300lm



6W 600lm



**Stood table**  
Lucid Product Design



29846

●● Matt Black + Cherry

<b>Material</b>	<b>Body Steel</b>
	<b>Shade Wood</b>
<b>Light Source</b>	1 E27 max. 15W
<b>Bulb incl.</b>	No
<b>Class</b>	II
<b>Voltage (V/Hz)</b>	100V-240V/50-60Hz
<b>Cable</b>	2 MT

**Stood floor**  
Lucid Product Design



29847

●● Matt Black + Cherry

<b>Material</b>	<b>Body Steel</b>
	<b>Shade Wood</b>
<b>Light Source</b>	1 E27 max. 15W
<b>Bulb incl.</b>	No
<b>Class</b>	II
<b>Voltage (V/Hz)</b>	100V-240V/50-60Hz
<b>Cable</b>	2 MT



**Suspended**  
204



**Wall**  
376

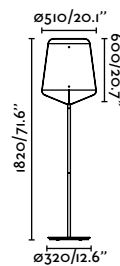
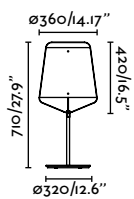

# Stood

Designed by Lucid Product Design



Stood table Ref. 29846

Nothing provides more wellbeing and warmth than natural wood.



Stood floor Ref. 29847

**Link table**  
Estudi Ribaudí

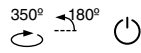

- 29881  Matt White
- 29882  Matt Black
- 29898  Bronze

<b>Material</b>	Body Steel
<b>Light Source</b>	1 GU10 max. 8W
<b>Bulb incl.</b>	No
<b>Class</b>	II
<b>Voltage (V/Hz)</b>	100V-240V/50-60Hz
<b>Cable</b>	1.9 MT

**Link floor**  
Estudi Ribaudí



- 29883  Matt White
- 29884  Matt Black
- 29899  Bronze

<b>Material</b>	Body Steel
<b>Light Source</b>	1 GU10 max. 8W
<b>Bulb incl.</b>	No
<b>Class</b>	II
<b>Voltage (V/Hz)</b>	100V-240V/50-60Hz
<b>Cable</b>	1.9 MT

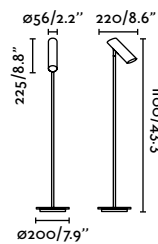
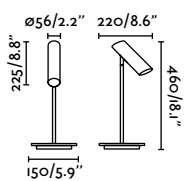
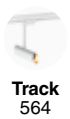
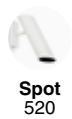

indoor

Table & Floor

# Link

Designed by Estudi Ribaudí



Link table Ref. 29881



**Akane 350**  
Pepe Llaudet



28370 ●● Matt Black + Beige

<b>Material</b>	<b>Body</b> Steel
	<b>Shade</b> Parchment
<b>Light Source</b>	1 E27 max. 15W
<b>Bulb incl.</b>	No
<b>Class</b>	II
<b>Voltage (V/Hz)</b>	100V-240V/50-60Hz
<b>Cable</b>	1.7 MT

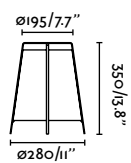

**Akane 595**  
Pepe Llaudet



28371 ●● Matt Black + Beige

<b>Material</b>	<b>Body</b> Steel
	<b>Shade</b> Parchment
<b>Light Source</b>	1 E27 max. 15W
<b>Bulb incl.</b>	No
<b>Class</b>	II
<b>Voltage (V/Hz)</b>	100V-240V/50-60Hz
<b>Cable</b>	1.7 MT

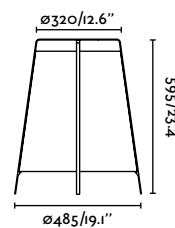

# Akane

Designed by Pepe Llaudet



Akane 595 Ref. 28371



Akane 350 Ref. 28370

With a parchment diffuser, it is inspired by the traditional lanterns of the Far East.

**Drum table**  
Nahtrang



- 24020-31  Matt Black + Beige
- 24020-32  Matt Black + Grey

<b>Material</b>	<b>Body</b> Steel
	<b>Diff</b> Opal PC
	<b>Shade</b> Textile
<b>Light Source</b>	1 E27 max. 15W
<b>Bulb incl.</b>	No
<b>Class</b>	II
<b>Voltage (V/Hz)</b>	100V-240V/50-60Hz
<b>Cable</b>	1.8 MT

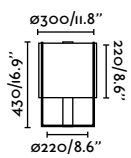

**Drum floor**  
Nahtrang



- 24023-33  Matt Black + Beige
- 24023-34  Matt Black + Grey

<b>Material</b>	<b>Body</b> Steel
	<b>Diff</b> Opal PC
	<b>Shade</b> Textile
<b>Light Source</b>	1 E27 max. 15W
<b>Bulb incl.</b>	No
<b>Class</b>	II
<b>Voltage (V/Hz)</b>	100V-240V/50-60Hz
<b>Cable</b>	2.1 MT

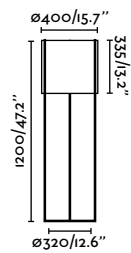

# Drum

Designed by Nahrang



Drum table Ref. 24020-31



Drum floor Ref. 24023-34

**Mambo table S**  
Faro Lab



64317-47 ●● Black + Rattan

**Mambo table**  
Faro Lab



64311-48 ●● Matt Black + Rattan

**Mambo floor**  
Faro Lab



Switch

64313-49 ●● Matt Black + Rattan

<b>Material</b>	<b>Body Steel</b>
	<b>Shade Rattan</b>
<b>Light Source</b>	1 E27 max. 15W
<b>Bulb incl.</b>	No
<b>Class</b>	II
<b>Voltage (V/Hz)</b>	100V-240V/50-60Hz
<b>Cable</b>	1.5 MT

<b>Material</b>	<b>Body Steel</b>
	<b>Shade Rattan</b>
<b>Light Source</b>	1 E27 max. 15W
<b>Bulb incl.</b>	No
<b>Class</b>	II
<b>Voltage (V/Hz)</b>	100V-240V/50-60Hz
<b>Cable</b>	1.5 MT

<b>Material</b>	<b>Body Steel</b>
	<b>Shade Rattan</b>
<b>Light Source</b>	1 E27 max. 15W
<b>Bulb incl.</b>	No
<b>Class</b>	II
<b>Voltage (V/Hz)</b>	100V-240V/50-60Hz
<b>Cable</b>	1.8 MT



**Suspended**  
281



**Wall**  
388

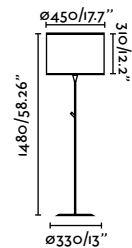
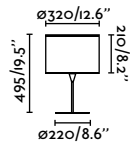
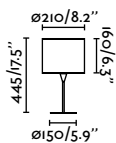

\*Structures and shades also sold separately 1408-1409



indoor

Table & Floor

# Mambo

Designed by Faro Lab



Mambo table Ref. 64311-48

**Samba table S**  
Faro Lab



- 64316-35  White + Beige
- 64316-36  White + Yellow
- 64316-37  White + Green
- 64317-35  Black + Beige
- 64317-36  Black + Yellow
- 64317-37  Black + Green

<b>Material</b>	<b>Body</b> Steel
	<b>Shade</b> Textile
<b>Light Source</b>	1 E27 max. 15W
<b>Bulb incl.</b>	No
<b>Class</b>	II
<b>Voltage (V/Hz)</b>	100V-240V/50-60Hz
<b>Cable</b>	1.5 MT

**Samba table**  
Faro Lab



- 64310-38  Matt White + Beige
- 64310-39  Matt White + Yellow
- 64310-40  Matt White + Green
- 64311-38  Matt Black + Beige
- 64311-39  Matt Black + Yellow
- 64311-40  Matt Black + Green

<b>Material</b>	<b>Body</b> Steel
	<b>Shade</b> Textile
<b>Light Source</b>	1 E27 max. 15W
<b>Bulb incl.</b>	No
<b>Class</b>	II
<b>Voltage (V/Hz)</b>	100V-240V/50-60Hz
<b>Cable</b>	1.5 MT

**Samba floor**  
Faro Lab



- 64312-41  Matt White + Beige
- 64312-42  Matt White + Yellow
- 64312-43  Matt White + Green
- 64313-41  Matt Black + Beige
- 64313-42  Matt Black + Yellow
- 64313-43  Matt Black + Green

<b>Material</b>	<b>Body</b> Steel
	<b>Shade</b> Textile
<b>Light Source</b>	1 E27 max. 15W
<b>Bulb incl.</b>	No
<b>Class</b>	II
<b>Voltage (V/Hz)</b>	100V-240V/50-60Hz
<b>Cable</b>	1.8 MT



**Suspended**  
238



**Wall**  
380

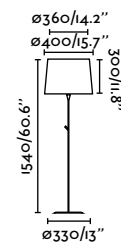
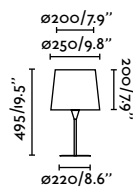
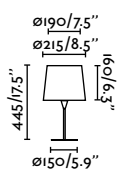

\*Structures and shades also sold separately 1408-1409

indoor

Table & Floor

# Samba

Designed by Faro Lab



Samba floor Ref. 64312-41

**Conga table S**  
Faro Lab



- 64316-01  White + White
- 64316-02  White + Beige
- 64317-03  Black + Black

**Conga table**  
Faro Lab



- 64310-04  Matt White + White
- 64310-05  Matt White + Beige
- 64311-06  Matt Black + Black

**Conga floor**  
Faro Lab

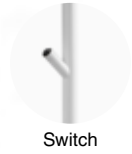

- 64312-07  Matt White + White
- 64312-08  Matt White + Beige
- 64313-09  Matt Black + Black

<b>Material</b>	<b>Body</b> Steel
	<b>Shade</b> Textile
<b>Light Source</b>	1 E27 max. 15W
<b>Bulb incl.</b>	No
<b>Class</b>	II
<b>Voltage (V/Hz)</b>	100V-240V/50-60Hz
<b>Cable</b>	1.5 MT

<b>Material</b>	<b>Body</b> Steel
	<b>Shade</b> Textile
<b>Light Source</b>	1 E27 max. 15W
<b>Bulb incl.</b>	No
<b>Class</b>	II
<b>Voltage (V/Hz)</b>	100V-240V/50-60Hz
<b>Cable</b>	1.5 MT

<b>Material</b>	<b>Body</b> Steel
	<b>Shade</b> Textile
<b>Light Source</b>	1 E27 max. 15W
<b>Bulb incl.</b>	No
<b>Class</b>	II
<b>Voltage (V/Hz)</b>	100V-240V/50-60Hz
<b>Cable</b>	1.8 MT

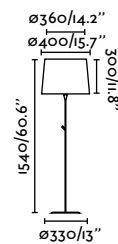
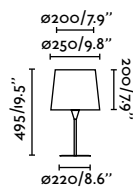
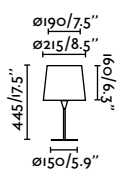
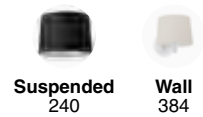

\*Structures and shades also sold separately 1408-1409

# Conga

Designed by Faro Lab



Conga table S Ref. 64317-03



Conga floor Ref. 64312-07



**Montreal table**  
Nahtrang



- 24034-04  Matt White + White
- 24034-05  Matt White + Beige

<b>Material</b>	<b>Body</b> Steel
	<b>Shade</b> Textile
<b>Light Source</b>	1 E27 max. 15W
<b>Bulb incl.</b>	No
<b>Class</b>	II
<b>Voltage (V/Hz)</b>	100V-240V/50-60Hz
<b>Cable</b>	1.8 MT

**Montreal floor**  
Nahtrang



- 24036-07  Matt White + White
- 24036-08  Matt White + Beige
- 24037-07  Chrome + White
- 24037-08  Chrome + Beige
- 24037-09  Chrome + Black

<b>Material</b>	<b>Body</b> Steel
	<b>Shade</b> Textile
<b>Light Source</b>	1 E27 max. 15W
<b>Bulb incl.</b>	No
<b>Class</b>	II
<b>Voltage (V/Hz)</b>	100V-240V/50-60Hz
<b>Cable</b>	2.1 MT



**Wall**  
382

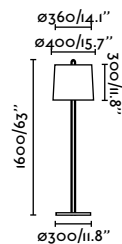
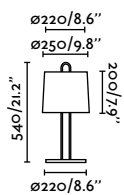

\*Structures and shades also sold separately 598-601

# Montreal

Designed by Nahtrang



**Savoy table**  
Isaac Piñeiro



- 20304-82  White + White
- 20305-83  Matt Black + Black
- 20305-84   Matt Black + Green

<b>Material</b>	<b>Body</b> Steel
	<b>Shade</b> Textile
<b>Light Source</b>	1 E27 max. 15W
<b>Bulb incl.</b>	No
<b>Class</b>	II
<b>Voltage (V/Hz)</b>	100V-240V/50-60Hz
<b>Cable</b>	2 MT

**Savoy floor**  
Isaac Piñeiro



- 20306-85  Matt White + White
- 20307-86  Matt Black + Black
- 20307-87   Matt Black + Green

<b>Material</b>	<b>Body</b> Steel
	<b>Shade</b> Textile
<b>Light Source</b>	1 E27 max. 15W
<b>Bulb incl.</b>	No
<b>Class</b>	II
<b>Voltage (V/Hz)</b>	100V-240V/50-60Hz
<b>Cable</b>	2 MT



**Suspended**  
242



**Wall**  
382

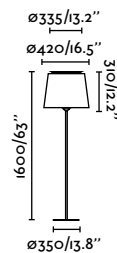
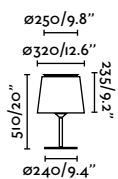

# Savoy

Designed by Isaac Piñeiro



Savoy table Ref. 20304-82



Savoy floor Ref. 20307-87

**Rem table**  
Àlex & Manel Llusçà



- 29685-04 Old Gold + White
- 29685-05 Old Gold + Beige
- 29685-06 Old Gold + Black

<b>Material</b>	<b>Body</b> Steel
	<b>Shade</b> Textile
<b>Light Source</b>	1 E27 max. 15W
<b>Bulb incl.</b>	No
<b>Class</b>	II
<b>Voltage (V/Hz)</b>	100V-240V/50-60Hz
<b>Cable</b>	1.6 MT

**Rem floor**  
Àlex & Manel Llusçà



- 29687-07 Old Gold + White
- 29687-08 Old Gold + Beige
- 29687-09 Old Gold + Black

<b>Material</b>	<b>Body</b> Steel
	<b>Shade</b> Textile
<b>Light Source</b>	1 E27 max. 15W
<b>Bulb incl.</b>	No
<b>Class</b>	II
<b>Voltage (V/Hz)</b>	100V-240V/50-60Hz
<b>Cable</b>	1.9 MT



Wall  
394

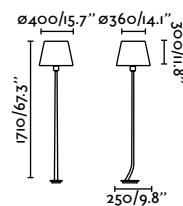
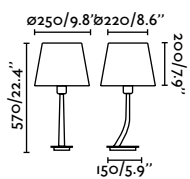

\*Structures and shades also sold separately 1408-1409



# Rem

Designed by Àlex & Manel Lluscà



**Artis table**  
Àlex & Manel Lluscà



68488 Bronze + White

<b>Material</b>	<b>Body</b> Steel
	<b>Shade</b> Textile
<b>Light Source</b>	1 E27 max. 15W
<b>Bulb incl.</b>	No
<b>Class</b>	II
<b>Voltage (V/Hz)</b>	100V-240V/50-60Hz
<b>Cable</b>	2.4 MT

**Artis floor**  
Àlex & Manel Lluscà



68489 Bronze + White

<b>Material</b>	<b>Body</b> Steel
	<b>Shade</b> Textile
<b>Light Source</b>	1 E27 max. 15W
<b>Bulb incl.</b>	No
<b>Class</b>	II
<b>Voltage (V/Hz)</b>	100V-240V/50-60Hz
<b>Cable</b>	3.2 MT



Wall  
390

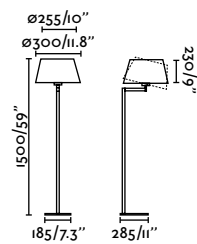
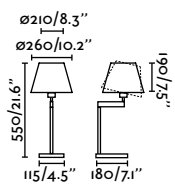

# Artis

Designed by Àlex & Manel Lluscà



Artis table Ref. 68488

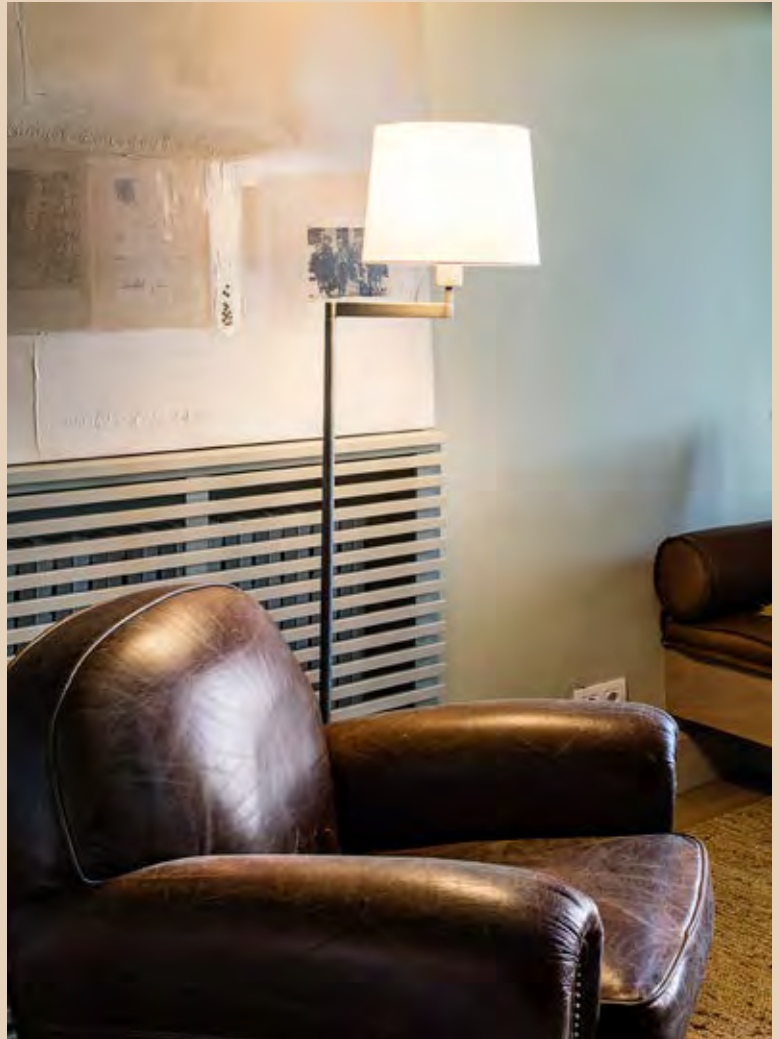

Artis floor Ref. 68489

## Nila table



20054

●● Matt Black + Off White

<b>Material</b>	<b>Body</b> Steel
	<b>Shade</b> Textile
<b>Light Source</b>	1 E27 max. 15W
<b>Bulb incl.</b>	No
<b>Class</b>	II
<b>Voltage (V/Hz)</b>	100V-240V/50-60Hz
<b>Cable</b>	1.5 MT

## Nila floor



20055

●● Matt Black + Off White

<b>Material</b>	<b>Body</b> Steel
	<b>Shade</b> Textile
<b>Light Source</b>	1 E27 max. 15W
<b>Bulb incl.</b>	No
<b>Class</b>	II
<b>Voltage (V/Hz)</b>	100V-240V/50-60Hz
<b>Cable</b>	2.3 MT



Wall  
342

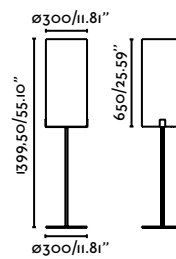
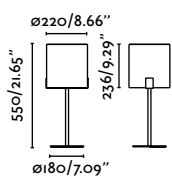



Nila table Ref. 20054



Nila floor Ref. 20055



**Vesper table**  
Nahtrang



- 29984  Matt White + Beige
- 29985  Brown + Beige

<b>Material</b>	<b>Body</b> Steel
	Diff Beige Textile
	<b>Shade</b> Textile
<b>Light Source</b>	2 E27 max. 15W
<b>Bulb incl.</b>	No
<b>Class</b>	II
<b>Voltage (V/Hz)</b>	100V-240V/50-60Hz
<b>Cable</b>	1.7 MT

**Vesper floor**  
Nahtrang

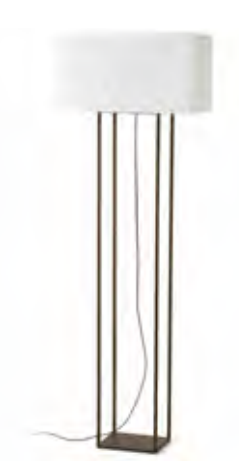

- 29979  Brown + Beige

<b>Material</b>	<b>Body</b> Steel
	Diff Beige Textile
	<b>Shade</b> Textile
<b>Light Source</b>	2 E27 max. 15W
<b>Bulb incl.</b>	No
<b>Class</b>	II
<b>Voltage (V/Hz)</b>	100V-240V/50-60Hz
<b>Cable</b>	3.5 MT



**Suspended**  
244



**Wall**  
406

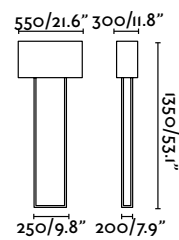
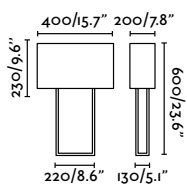

# Vesper

Designed by Nahtrang



Vesper table Ref. 29985



Vesper floor Ref. 29979

**Linda table**  
Estudi Ribaudí



- 29307  Matt White + Beige
- 29311  Matt Black + Beige

<b>Material</b>	<b>Body</b> Steel
	<b>Shade</b> Textile
<b>Light Source</b>	1 E27 max. 15W
<b>Bulb incl.</b>	No
<b>Class</b>	II
<b>Voltage (V/Hz)</b>	100V-240V/50-60Hz
<b>Cable</b>	2 MT

**Linda floor**  
Estudi Ribaudí



- 29312  Matt Black + Beige

<b>Material</b>	<b>Body</b> Steel
	<b>Shade</b> Textile
<b>Light Source</b>	1 E27 max. 15W
<b>Bulb incl.</b>	No
<b>Class</b>	II
<b>Voltage (V/Hz)</b>	100V-240V/50-60Hz
<b>Cable</b>	2.8 MT



**Suspended**  
246



**Wall**  
474

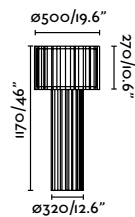
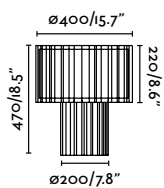

# Linda

Designed by Estudi Ribaudí

Indoor

Table & Floor

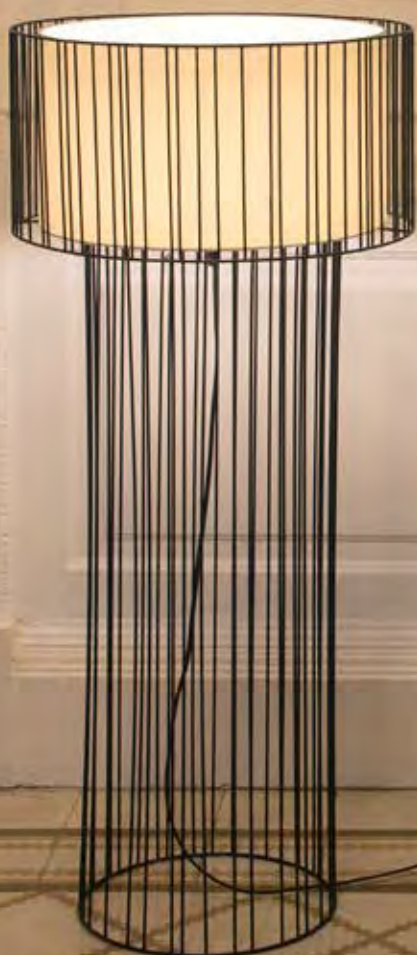

**Lupe table**  
Jordi Busquets



29997 Chrome + Beige

<b>Material</b>	<b>Body</b> Steel
	<b>Shade</b> Textile
<b>Light Source</b>	1 E27 max. 15W
<b>Bulb incl.</b>	No
<b>Class</b>	II
<b>Voltage (V/Hz)</b>	100V-240V/50-60Hz
<b>Cable</b>	1.8 MT

**Lupe**  
Jordi Busquets

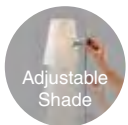

20034-88 Matt Black + Beige  
29998 Chrome + Beige

<b>Material</b>	<b>Body</b> Steel
	<b>Shade</b> Textile
<b>Light Source</b>	1 E27 max. 15W
<b>Bulb incl.</b>	No
<b>Class</b>	II
<b>Voltage (V/Hz)</b>	100V-240V/50-60Hz
<b>Cable</b>	3.5 MT



**Wall**  
398

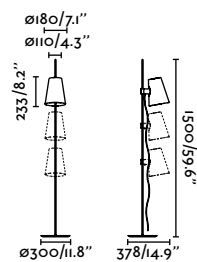
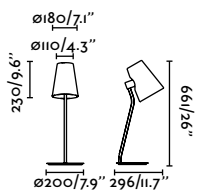



# Lupe

Designed by Jordi Busquets



Lupe table Ref. 29997

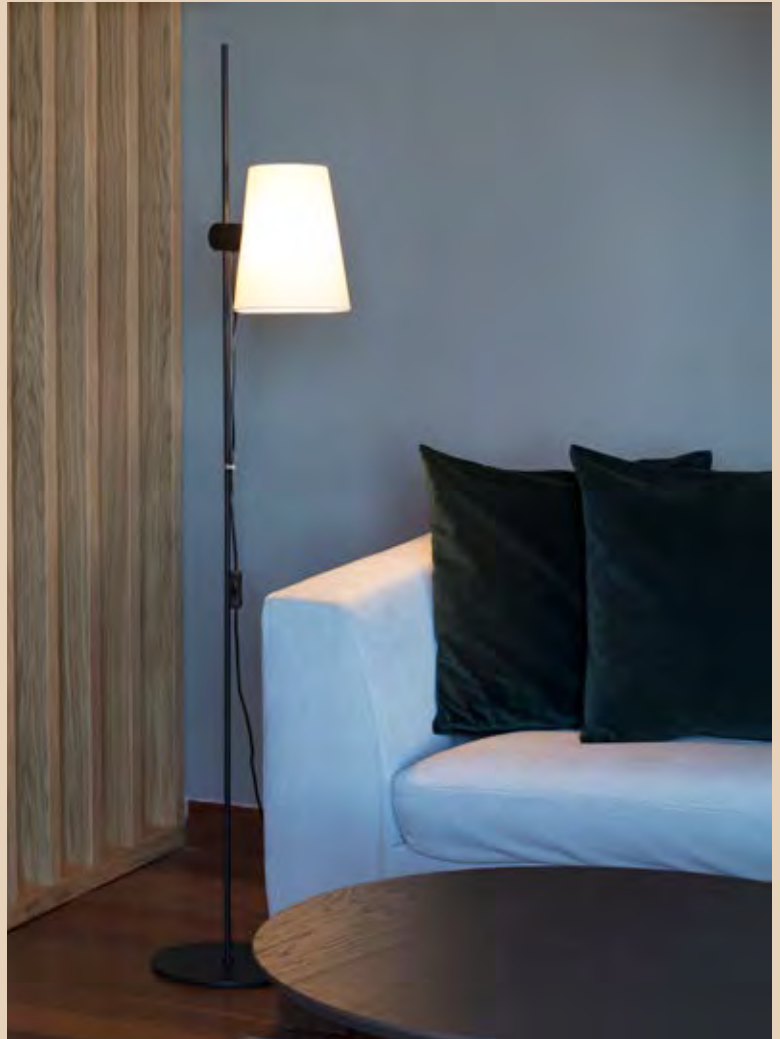

Lupe Ref. 20034-88

**Tree table**  
Estudi Ribaudí



- 29866  Matt Black + Black
- 29867  Matt White + White

<b>Material</b>	<b>Body</b> Steel
	<b>Shade</b> Textile
<b>Light Source</b>	1 E27 max. 15W
<b>Bulb incl.</b>	No
<b>Class</b>	II
<b>Voltage (V/Hz)</b>	100V-240V/50-60Hz
<b>Cable</b>	1.8 MT

**Tree floor**  
Estudi Ribaudí



- 29868  Matt Black + Black
- 29869  Matt White + White

<b>Material</b>	<b>Body</b> Steel
	<b>Shade</b> Textile
<b>Light Source</b>	1 E27 max. 15W
<b>Bulb incl.</b>	No
<b>Class</b>	II
<b>Voltage (V/Hz)</b>	100V-240V/50-60Hz
<b>Cable</b>	2 MT



**Suspended**  
246

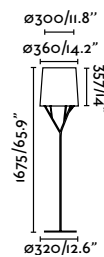
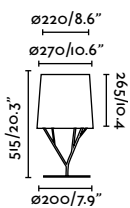

# Tree

Designed by Estudi Ribaudí



**Berni table**  
Nahtrang



- 29332  Matt White + White
- 29333  Matt Black + Black

<b>Material</b>	<b>Body</b> Steel
	<b>Shade</b> Textile
<b>Light Source</b>	1 E27 max. 15W
<b>Bulb incl.</b>	No
<b>Class</b>	II
<b>Voltage (V/Hz)</b>	100V-240V/50-60Hz
<b>Cable</b>	1.5 MT

**Berni floor**  
Nahtrang



- 29335  Matt White + White
- 29336  Matt Black + Black

<b>Material</b>	<b>Body</b> Steel
	<b>Shade</b> Textile
<b>Light Source</b>	1 E27 max. 15W
<b>Bulb incl.</b>	No
<b>Class</b>	II
<b>Voltage (V/Hz)</b>	100V-240V/50-60Hz
<b>Cable</b>	1.5 MT



**Wall**  
408

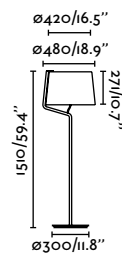
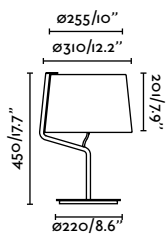

# Berni

Designed by Nahtrang





**Hotel floor**  
Àlex & Manel Llusçà



29948

●● Matt Black + Black

<b>Material</b>	<b>Body</b> Steel
	<b>Diff</b> Black Textile
	<b>Shade</b> Textile
<b>Light Source</b>	1 E27 max. 15W
<b>Bulb incl.</b>	No
<b>Class</b>	II
<b>Voltage (V/Hz)</b>	100V-240V/50-60Hz
<b>Cable</b>	1.9 MT



**Suspended**  
246



**Wall**  
402

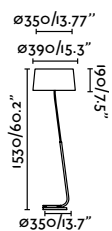

# Hotel

Designed by Àlex & Manel Llusca



**Volta table**  
Estudi Ribaudí



- 20025  Matt White + White
- 20026  Matt Black + Black

<b>Material</b>	<b>Body</b> Steel
	<b>Shade</b> Textile
<b>Light Source</b>	1 E27 max. 15W
<b>Bulb incl.</b>	No
<b>Class</b>	II
<b>Voltage (V/Hz)</b>	100V-240V/50-60Hz
<b>Cable</b>	2 MT

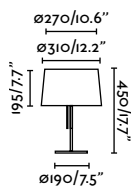

**Volta floor**  
Estudi Ribaudí



- 20029  Matt White + White
- 20030  Matt Black + Black

<b>Material</b>	<b>Body</b> Steel
	<b>Shade</b> Textile
<b>Light Source</b>	1 E27 max. 15W
<b>Bulb incl.</b>	No
<b>Class</b>	II
<b>Voltage (V/Hz)</b>	100V-240V/50-60Hz
<b>Cable</b>	2 MT

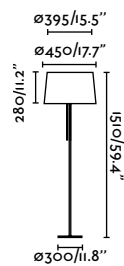

# Volta

Designed by Estudi Ribaudí



Volta table Ref. 20025



Volta floor Ref. 20030

**Stand Up**  
Estudi Ribaudí



- 57211-01  Matt Black + White
- 57211-03  Matt Black + Grey

<b>Material</b>	<b>Body</b> Aluminium
	<b>Shade</b> Textilene
<b>Light Source</b>	1 E27 max. 15W
<b>Bulb incl.</b>	No
<b>Class</b>	II
<b>Voltage (V/Hz)</b>	100V-240V/50-60Hz
<b>Cable</b>	2 MT

**Whizz**  
Christoph F.W.



- 20164-95  Matt Black + Black
- 20164-96  Matt Black + Satin Gold

<b>Material</b>	<b>Body</b> Steel
	<b>Shade</b> Steel
<b>Light Source</b>	1 E27 max. 15W
<b>Bulb incl.</b>	No
<b>Class</b>	II
<b>Voltage (V/Hz)</b>	100V-240V/50-60Hz
<b>Cable</b>	3.4 MT

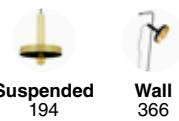

**Suspended**  
194

**Wall**  
366

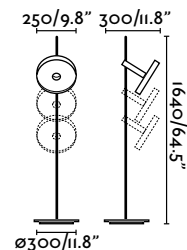
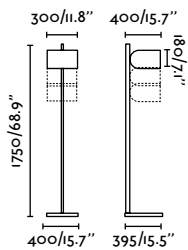



# Stand Up & Whizz



Stand Up Ref. 57211-03



Whizz Ref. 20164-95

**Guest**  
Andreu Carulla



01046

● Matt Black

<b>Material</b>	Body Steel
<b>Light Source</b>	1 E27 max. 15W
<b>Bulb incl.</b>	No
<b>Class</b>	II
<b>Voltage (V/Hz)</b>	100V-240V/50-60Hz
<b>Cable</b>	1.8 MT

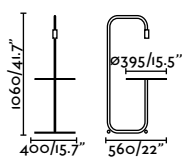

# Guest

Designed by Andreu Carulla



## Moma table



- 68500  Chrome + White
- 68501  Chrome + Black

<b>Material</b>	<b>Body</b> Steel
	<b>Diff</b> Opal PC
	<b>Shade</b> Textile
<b>Light Source</b>	1 E27 max. 15W
<b>Bulb incl.</b>	No
<b>Class</b>	II
<b>Voltage (V/Hz)</b>	100V-240V/50-60Hz
<b>Cable</b>	1.9 MT

## Moma floor



- 68503  Chrome + Black

<b>Material</b>	<b>Body</b> Steel
	<b>Diff</b> Opal PC
	<b>Shade</b> Textile
<b>Light Source</b>	1 E27 max. 15W
<b>Bulb incl.</b>	No
<b>Class</b>	II
<b>Voltage (V/Hz)</b>	100V-240V/50-60Hz
<b>Cable</b>	2.1 MT



Wall  
416

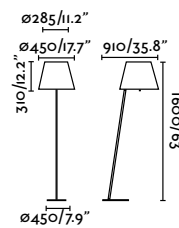
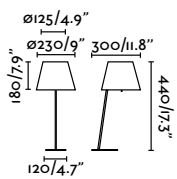

Moma

indoor

Table & Floor





**Sweet table**  
Estudi Ribaudí



29955

●● Matt Black + Black

<b>Material</b>	<b>Body</b> Steel
	<b>Diff</b> Black Textile
	<b>Shade</b> Textile
<b>Light Source</b>	1 E27 max. 15W
<b>Bulb incl.</b>	No
<b>Class</b>	II
<b>Voltage (V/Hz)</b>	100V-240V/50-60Hz
<b>Cable</b>	1.9 MT

**Sweet floor**  
Estudi Ribaudí



29958

●● Matt White + White

<b>Material</b>	<b>Body</b> Steel
	<b>Diff</b> White Textile
	<b>Shade</b> Textile
<b>Light Source</b>	1 E27 max. 15W
<b>Bulb incl.</b>	No
<b>Class</b>	II
<b>Voltage (V/Hz)</b>	100V-240V/50-60Hz
<b>Cable</b>	1.7 MT



Wall  
410

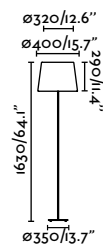
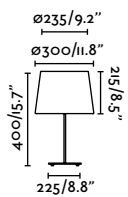

# Sweet

Designed by Estudi Ribaudí



Sweet floor Ref. 29958

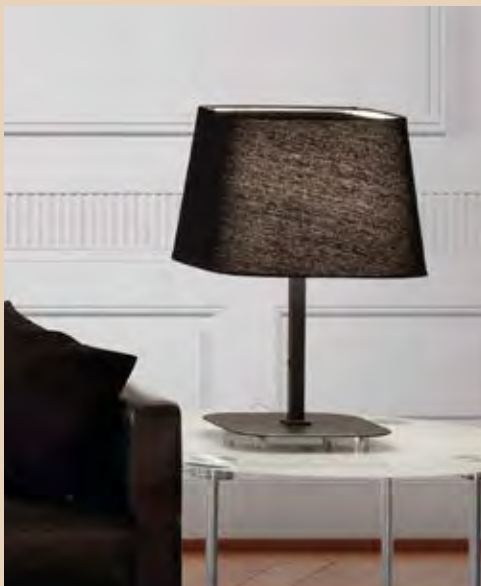

Sweet table Ref. 29955

## Papua



- 68462  Matt White + White
- 68463  Matt Black + Black

<b>Material</b>	<b>Body</b> Steel
	<b>Shade</b> Textile
<b>Light Source</b>	1 E27 max. 15W
<b>Bulb incl.</b>	No
<b>Class</b>	II
<b>Voltage (V/Hz)</b>	100V-240V/50-60Hz
<b>Cable</b>	2 MT

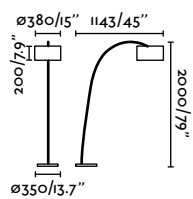

## Black



- 29764  Shiny Black + Black

<b>Material</b>	<b>Body</b> Steel
	<b>Shade</b> Textile
<b>Light Source</b>	1 E27 max. 15W
<b>Bulb incl.</b>	No
<b>Class</b>	II
<b>Voltage (V/Hz)</b>	100V-240V/50-60Hz
<b>Cable</b>	2.5 MT

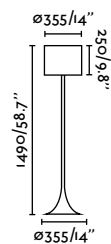

# Papua & Black



Black Ref. 29764



Papua Ref. 68463





# SUSPENDED

**Studio 110**  
Nahrang



- 28260  Matt Black + Black
- 28261   Matt Black + White
- 28262   Matt Black + Green
- 28277   Matt Black + Blue
- 28278   Matt Black + Pink

<b>Material</b>	<b>Body Steel</b>
	<b>Shade Steel</b>
<b>Light Source</b>	1 E14 max. 8W
<b>Bulb incl.</b>	No
<b>Class</b>	II
<b>Voltage (V/Hz)</b>	100V-240V/50-60Hz
<b>Cable</b>	2 MT

**Studio 160**  
Nahrang



- 28263   Matt Black + Black
- 28264   Matt Black + White
- 28265   Matt Black + Green
- 28279   Matt Black + Blue
- 28280   Matt Black + Pink

<b>Material</b>	<b>Body Steel</b>
	<b>Shade Steel</b>
<b>Light Source</b>	1 E27 max. 15W
<b>Bulb incl.</b>	No
<b>Class</b>	II
<b>Voltage (V/Hz)</b>	100V-240V/50-60Hz
<b>Cable</b>	2 MT

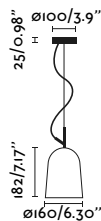

**Studio 290**  
Nahrang



- 28283   Matt Black + Black
- 28284   Matt Black + White
- 28285   Matt Black + Green
- 28286   Matt Black + Blue
- 28287   Matt Black + Pink

<b>Material</b>	<b>Body Steel</b>
	<b>Shade Steel</b>
<b>Light Source</b>	1 E27 max. 18W
<b>Bulb incl.</b>	No
<b>Class</b>	II
<b>Voltage (V/Hz)</b>	100V-240V/50-60Hz
<b>Cable</b>	2 MT

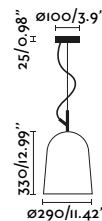

indoor

Suspended

# Studio NEW

Designed by Nahtrang

Studio brings back lines from the 1950s and reinterprets them to fit into a modern context.



Studio 290 Ref. 28287



Studio 110 Ref. 28277

The main feature of its design that makes it unique is the way the cable is attached to the structure.

**Studio lineal**  
Nahrang

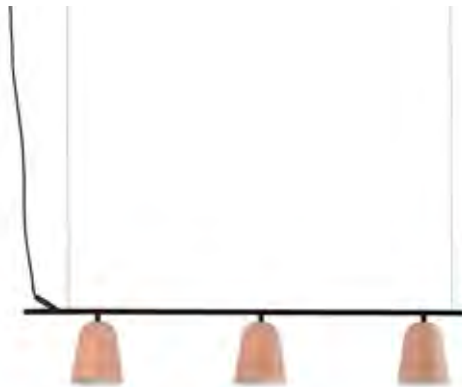

- 28266 ●● Matt Black + Black
- 28267 ●● Matt Black + White
- 28268 ●● Matt Black + Green
- 28281 ●● Matt Black + Blue
- 28282 ●● Matt Black + Pink

<b>Material</b>	<b>Body</b> Steel
	<b>Shade</b> Steel
<b>Light Source</b>	3 E14 max. 8W
<b>Bulb incl.</b>	No
<b>Class</b>	II
<b>Voltage (V/Hz)</b>	100V-240V/50-60Hz
<b>Cable</b>	2 MT



**Table&Floor**  
72



**Wall**  
324

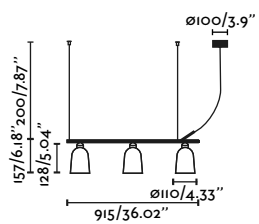

indoor

Suspended





**Isabelle 310**  
Héctor Serrano



**28300** ●● Matt White + Opal

**Isabelle 400**  
Héctor Serrano



**28301** ●● Matt White + Opal

**Isabelle 500**  
Héctor Serrano



**28302** ●● Matt White + Opal

<b>Material</b>	<b>Body Steel</b>
	<b>Shade Glass</b>
<b>Light Source</b>	1 E27 max. 15W
<b>Bulb incl.</b>	No
<b>Class</b>	II
<b>Voltage (V/Hz)</b>	100V-240V/50-60Hz
<b>Cable</b>	2 MT

<b>Material</b>	<b>Body Steel</b>
	<b>Shade Glass</b>
<b>Light Source</b>	1 E27 max. 15W
<b>Bulb incl.</b>	No
<b>Class</b>	II
<b>Voltage (V/Hz)</b>	100V-240V/50-60Hz
<b>Cable</b>	2 MT

<b>Material</b>	<b>Body Steel</b>
	<b>Shade Glass</b>
<b>Light Source</b>	1 E27 max. 15W
<b>Bulb incl.</b>	No
<b>Class</b>	II
<b>Voltage (V/Hz)</b>	100V-240V/50-60Hz
<b>Cable</b>	2 MT

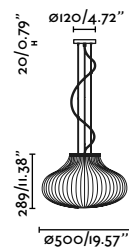
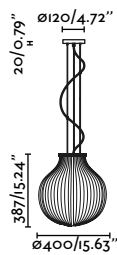
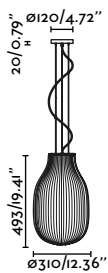

# Isabelle

NEW

Designed by Héctor Serrano

Three models that can be implemented individually or together depending on architectural needs.



The opal glass diffuser emits a soft, warm light filtered by its waves.



Isabelle 500 Ref. 28302

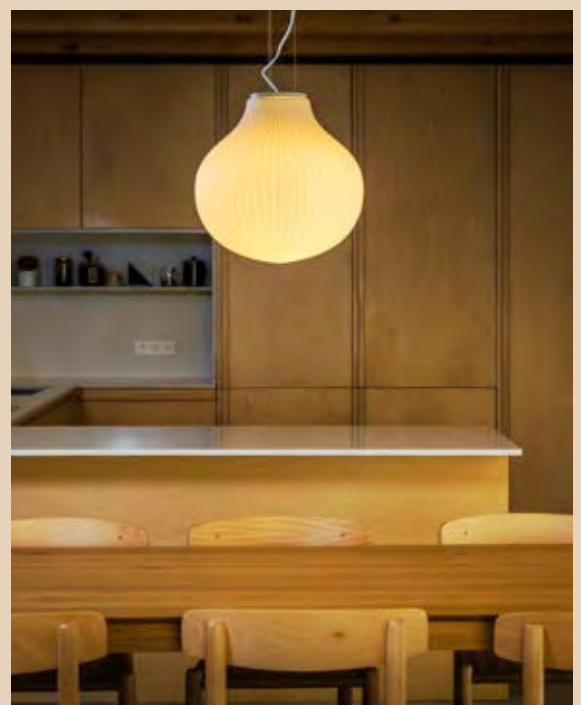

Isabelle 400 Ref. 28301

**Tatawin S**  
Adolfo Abejón



- 20339-116 ●● Satin Black + Opal
- 20339-117 ●● Satin Black + Shiny Black

<b>Material</b>	<b>Body</b> Steel
	<b>Shade</b> Glass
<b>Light Source</b>	1 E27 G45 max. 15W
<b>Bulb incl.</b>	No
<b>Class</b>	II
<b>Voltage (V/Hz)</b>	100V-240V/50-60Hz
<b>Cable</b>	1.5 MT

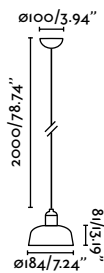

**Tatawin M**  
Adolfo Abejón



- 20339-119 ●● Satin Black + Opal
- 20339-120 ●● Satin Black + Shiny Black

<b>Material</b>	<b>Body</b> Steel
	<b>Shade</b> Glass
<b>Light Source</b>	1 E27 max. 15W
<b>Bulb incl.</b>	No
<b>Class</b>	II
<b>Voltage (V/Hz)</b>	100V-240V/50-60Hz
<b>Cable</b>	1.5 MT

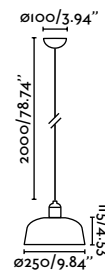

indoor

Suspended

# Tatawin

Designed by Adolfo Abejón

Inspired by  
the houses  
of Tataouine,  
Tunisia.



**Tatawin lineal S**  
Adolfo Abejón

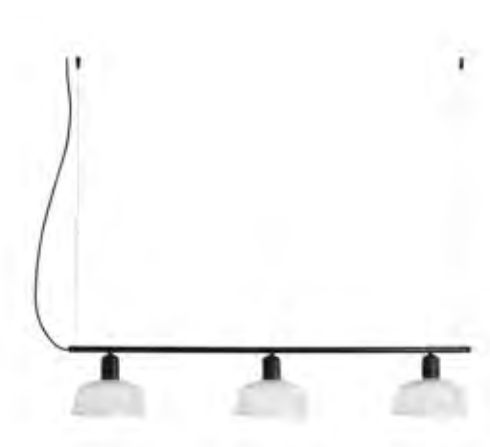

- 20338-116 ●○ Satin Black + Opal
- 20338-117 ●● Satin Black + Shiny Black

<b>Material</b>	<b>Body Steel</b>
	<b>Shade Glass</b>
<b>Light Source</b>	3 E27 G45 max. 15W
<b>Bulb incl.</b>	No
<b>Class</b>	II
<b>Voltage (V/Hz)</b>	100V-240V/50-60Hz
<b>Cable</b>	2 MT

**Tatawin lineal M**  
Adolfo Abejón



- 20338-119 ●○ Satin Black + Opal
- 20338-120 ●● Satin Black + Shiny Black

<b>Material</b>	<b>Body Steel</b>
	<b>Shade Glass</b>
<b>Light Source</b>	3 E27 max. 15W
<b>Bulb incl.</b>	No
<b>Class</b>	II
<b>Voltage (V/Hz)</b>	100V-240V/50-60Hz
<b>Cable</b>	2 MT

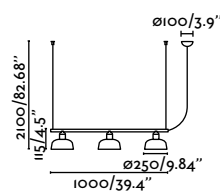
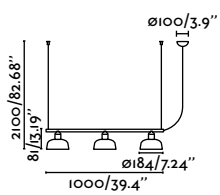



indoor

Suspended



**Tatawin circular**  
Adolfo Abejón

NEW



- 20343-116-5L ● ○ Satin Black + Opal
- 20343-117-5L ● ● Satin Black + Shiny Black

<b>Material</b>	<b>Body Steel</b>
	<b>Shade Glass</b>
<b>Light Source</b>	5 E27 G45 max. 15W
<b>Bulb incl.</b>	No
<b>Class</b>	II
<b>Voltage (V/Hz)</b>	100V-240V/50-60Hz
<b>Cable</b>	2.5 MT

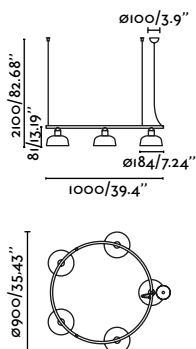

**Tatawin circular**  
Adolfo Abejón

NEW



- 20343-119-5L ● ○ Satin Black + Opal
- 20343-120-5L ● ● Satin Black + Shiny Black

<b>Material</b>	<b>Body Steel</b>
	<b>Shade Glass</b>
<b>Light Source</b>	5 E27 G45 max. 15W
<b>Bulb incl.</b>	No
<b>Class</b>	II
<b>Voltage (V/Hz)</b>	100V-240V/50-60Hz
<b>Cable</b>	2.5 MT

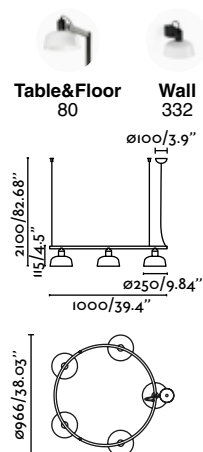

indoor

Suspended



# Venice

**Designed by** Adolfo Abejón

Designed and handcrafted  
in Barcelona.



Installation is easy and intuitive, thanks  
to a thin slit through which the cable  
passes and the light escapes.









**Venice 160**  
Adolfo Abejón



- 64255 ●● Shiny Black + Shiny White
- 64256 ●● Shiny Black + Shiny Black
- 64258 ●||| Shiny Black + Black & White Gloss
- 64257 ●● Shiny Black + Gloss Pink
- 64259 ●● Shiny Black + Blue

<b>Material</b>	<b>Body</b> Steel
	<b>Shade</b> Ceramic
<b>Light Source</b>	1 E27 max. 15W
<b>Bulb incl.</b>	No
<b>Class</b>	II
<b>Voltage (V/Hz)</b>	100V-240V/50-60Hz
<b>Cable</b>	1.5 MT

**Venice 200**  
Adolfo Abejón



- 64255-124 ●● Black + White
- 64255-125 ●● Black + Shiny Black
- 64255-126 ●● Black + Pink
- 64255-128 ●● Black + Blue
- 64255-127 ●||| Black + Black & White Gloss

<b>Material</b>	<b>Body</b> Steel
	<b>Shade</b> Ceramic
<b>Light Source</b>	1 E27 max. 15W
<b>Bulb incl.</b>	No
<b>Class</b>	II
<b>Voltage (V/Hz)</b>	100V-240V/50-60Hz
<b>Cable</b>	1.5 MT



**Table&Floor**  
84



**Wall**  
354

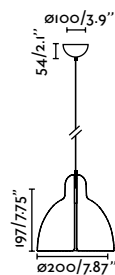
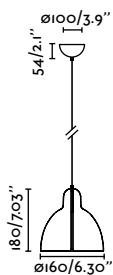

indoor

Suspended



**Whizz**  
Christoph F.W.

NEW



- 20160   Black + Satin Gold
- 20161   Satin Gold + Black
- 20169   Blue + Matt White

<b>Material</b>	<b>Body</b> Steel
	<b>Shade</b> Steel
<b>Light Source</b>	1 E27 max. 15W
<b>Bulb incl.</b>	No
<b>Class</b>	II
<b>Voltage (V/Hz)</b>	100V-240V/50-60Hz
<b>Cable</b>	1.5 MT

**Whizz pendant floor**  
Christoph F.W.



- 20166-95   Matt Black + Black
- 20166-96   Matt Black + Satin Gold

<b>Material</b>	<b>Body</b> Steel
	<b>Shade</b> Steel
<b>Light Source</b>	1 E27 max. 15W
<b>Bulb incl.</b>	No
<b>Class</b>	II
<b>Voltage (V/Hz)</b>	100V-240V/50-60Hz
<b>Cable</b>	3.4 MT



**Floor**  
166



**Wall**  
366

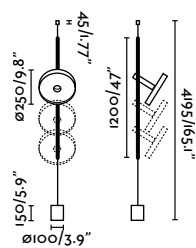
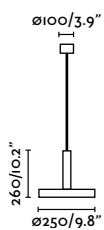

indoor

Suspended

# Whizz

Designed by Christoph F.W.

Whizz incorporates current trends by combining different finishes in a wonderfully stylish way.

salone  
satellite  
20 years  
of new  
creativity



Whizz Ref. 20169



Whizz pendant floor Ref. 20166-95



# Liggera

350°



20079

● Matt Black

<b>Material</b>	<b>Body Steel</b>
	<b>Shade Steel</b>
<b>Light Source</b>	6 G9 max. 6W
<b>Bulb incl.</b>	No
<b>Class</b>	II
<b>Voltage (V/Hz)</b>	100V-240V/50-60Hz



**Table&Floor**  
94



**Wall**  
336

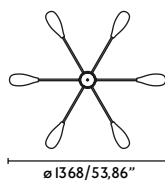
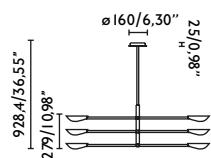



indoor

Suspended

# Liggera NEW

Its soft and natural forms are inspired by ancient Japanese minimalism.



**Confetti 300**  
Nutcreatives



68600-50  Matt Black + White & Black

<b>Material</b>	<b>Body</b> Aluminium
	<b>Shade</b> Recycled PET
<b>Light Source</b>	1 E27 max. 15W
<b>Bulb incl.</b>	No
<b>Class</b>	II
<b>Voltage (V/Hz)</b>	100V-240V/50-60Hz
<b>Cable</b>	1.5 MT

**Confetti 450**  
Nutcreatives



68600-51  Matt Black + White & Black

<b>Material</b>	<b>Body</b> Aluminium
	<b>Shade</b> Recycled PET
<b>Light Source</b>	1 E27 max. 15W
<b>Bulb incl.</b>	No
<b>Class</b>	II
<b>Voltage (V/Hz)</b>	100V-240V/50-60Hz
<b>Cable</b>	1.5 MT



**Wall**  
346

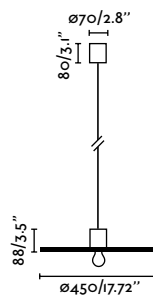
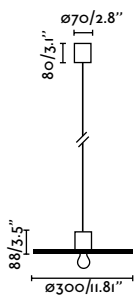

indoor

Suspended

# Confetti

**Designed by** Nutcreatives

Locally produced,  
made from recycled  
plastic from bottle caps.



Less is more!  
Made from recycled plastic  
shavings.

**Vico 600**  
Faro Lab

incl. DIM TRIAC L



61101-110 ● Matt Black

**Vico 600 canopy recessed**

61105-110 ● Matt Black

<b>Material</b>	<b>Body</b> Aluminium
	Diff Opal PC
<b>Power</b>	15W
<b>Lumen Output</b>	1500lm
<b>Light Source</b>	SMD LED 2700K
<b>Class</b>	II
<b>CRI</b>	>=90
<b>Voltage (V/Hz)</b>	110V/50Hz
<b>Cable</b>	2 MT

**Vico 1150**  
Faro Lab

incl. DIM TRIAC L



61103-110 ● Matt Black

**Vico 1150 canopy recessed**

61104-110 ● Matt Black

<b>Material</b>	<b>Body</b> Aluminium
	Diff Opal PC
<b>Power</b>	30W
<b>Lumen Output</b>	2800lm
<b>Light Source</b>	MODULO LED 2700K
<b>Class</b>	II
<b>CRI</b>	>=90
<b>Voltage (V/Hz)</b>	110V/50Hz
<b>Cable</b>	2 MT



**Join kir accessory**

61117 ● Matt Black

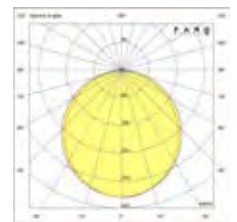
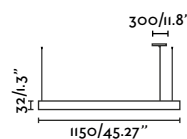
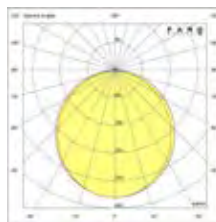
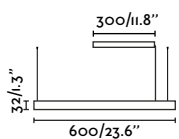

\*More dimmable options under request

# Vico

Designed by Faro Lab



Provides homogeneous and soft light without causing glare.

Pure lines,  
comfort and  
elegance.











Vico 600 canopy recessed Ref. 61105-110



**Saigon in 700**  
Nahtrang











- 20116  Matt Black + Beige
- 20117  Matt Black + White
- 20118  Matt Black + Terracotta
- 20119  Matt Black + Black
- 20120  Matt Black + Yellow
- 20121  Matt Black + Garnet
- 20122  Matt Black + Green
- 20123  Matt Black + Brown

<b>Material</b>	<b>Body Steel</b>
	Diff Beige Papyrus
	Shade Textile ribbon
<b>Light Source</b>	3 E27 max. 15W
<b>Bulb incl.</b>	No
<b>Class</b>	II
<b>Voltage (V/Hz)</b>	100V-240V/50-60Hz
<b>Cable</b>	1.6 MT

**Saigon in 1300**  
Nahtrang



- 20124  Matt Black + Beige
- 20125  Matt Black + White
- 20126  Matt Black + Terracotta
- 20127  Matt Black + Black
- 20128  Matt Black + Yellow
- 20129  Matt Black + Garnet
- 20130  Matt Black + Green
- 20131  Matt Black + Brown

<b>Material</b>	<b>Body Steel</b>
	Diff Beige Papyrus
	Shade Textile ribbon
<b>Light Source</b>	4 E27 max. 15W
<b>Bulb incl.</b>	No
<b>Class</b>	II
<b>Voltage (V/Hz)</b>	100V-240V/50-60Hz
<b>Cable</b>	1.6 MT

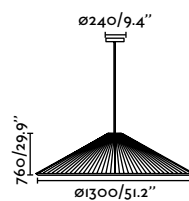
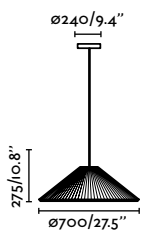

indoor

Suspended

# Saigon

Designed by Nahtrang

It offers an infinite number of combinations and functionalities.



Saigon in 1300 Ref. 20128



The high quality of its materials and the attention to detail on its finishing are essential.

**Stood**  
Lucid Product Design



29848

●● Matt Black + Cherry

<b>Material</b>	<b>Body</b> Steel
	<b>Shade</b> Wood
<b>Light Source</b>	1 E27 max. 15W
<b>Bulb incl.</b>	No
<b>Class</b>	II
<b>Voltage (V/Hz)</b>	100V-240V/50-60Hz
<b>Cable</b>	2 MT

**Stood 5L**  
Lucid Product Design



29849

●● Matt Black + Cherry

<b>Material</b>	<b>Body</b> Steel
	<b>Shade</b> Wood
<b>Light Source</b>	5 E27 max. 15W
<b>Bulb incl.</b>	No
<b>Class</b>	II
<b>Voltage (V/Hz)</b>	100V-240V/50-60Hz
<b>Cable</b>	2 MT



**Table&Floor**  
128



**Wall**  
376

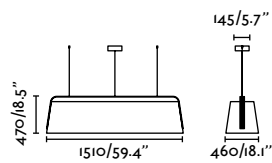
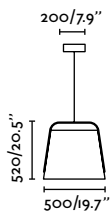

indoor

Suspended

# Stood

Designed by Lucid Product Design



**Retro**  
Àlex & Manel Llusca



- 20046   Matt Copper + Matt Black
- 20050   Matt Black + Chrome

<b>Material</b>	Body Steel
<b>Light Source</b>	1 E14 max. 8W
<b>Bulb incl.</b>	No
<b>Class</b>	I
<b>Voltage (V/Hz)</b>	100V-240V/50-60Hz
<b>Cable</b>	1.6 MT

**Retro 12L**  
Àlex & Manel Llusca



- 20047   Matt Copper + Matt Black
- 20048   Matt Black + Chrome
- 20051   Matt Black + Satin Gold

<b>Material</b>	Body Steel
<b>Light Source</b>	12 E14 max. 8W
<b>Bulb incl.</b>	No
<b>Class</b>	I
<b>Voltage (V/Hz)</b>	100V-240V/50-60Hz
<b>Cable</b>	3 MT



Wall  
474

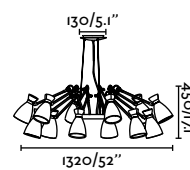
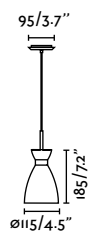



indoor

Suspended

# Retro

Designed by Àlex & Manel Llusçà



Retro Ref. 20050



**Le vita**  
Nahtrang

incl. 

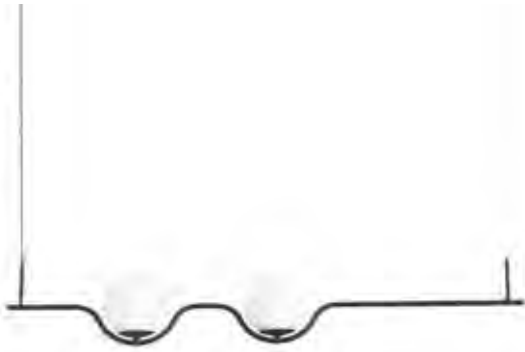

- 29691-110  Shiny Gold
- 29696-110  Matt Black

	Diff Opal Glass
<b>Power</b>	13W
<b>Lumen Output</b>	600lm
<b>Light Source</b>	SMD LED 2700K
<b>CRI</b>	>80
<b>Voltage (V/Hz)</b>	110V/50-60Hz
<b>Cable</b>	1.5 MT



**Table&Floor**  
124



**Wall**  
362

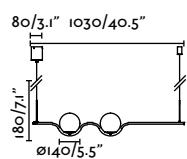

indoor

Suspended

# Levita

Designed by Nahtrang



Ref. 29691-110

Thanks to Estudio Ana Martí

**Mine Glass**  
Nahtrang



- 28375  Matt White
- 28376  Dark Grey

<b>Material</b>	<b>Body</b> Aluminium+Wood
	<b>Diff</b> Opal Glass
<b>Light Source</b>	1 E27 max. 15W
<b>Bulb incl.</b>	No
<b>Class</b>	II
<b>Voltage (V/Hz)</b>	100V-240V/50-60Hz
<b>Cable</b>	4 MT

**Mine PC**  
Nahtrang



- 28209  Matt White
- 28210  Dark Grey

<b>Material</b>	<b>Body</b> Aluminium+Wood
	<b>Diff</b> Opal PC
<b>Light Source</b>	1 E27 max. 15W
<b>Bulb incl.</b>	No
<b>Class</b>	II
<b>Voltage (V/Hz)</b>	100V-240V/50-60Hz
<b>Cable</b>	4 MT



**Table**  
106

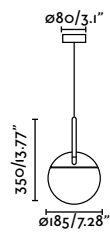
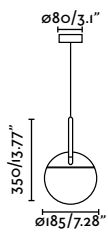

# Mine

**Designed by** Nahtrang

Sober and nordic style.  
It presents a relaxed  
aesthetic thanks to its  
shapes and soft finishes.



Mine PC Ref. 28376

**Mine Glass Space**  
Nahrang



- 28375-1L  Matt White
- 28376-1L  Dark Grey

<b>Material</b>	<b>Body</b> Aluminium+Wood
	<b>Diff</b> Glass
<b>Light Source</b>	1 E27 max. 15W
<b>Bulb incl.</b>	No
<b>Class</b>	II
<b>Voltage (V/Hz)</b>	100V-240V/50-60Hz
<b>Cable</b>	2 MT

**Mine PC Space**  
Nahrang



- 28209-1L  Matt White
- 28210-1L  Dark Grey

<b>Material</b>	<b>Body</b> Aluminium+Wood
	<b>Diff</b> PC
<b>Light Source</b>	1 E27 max. 15W
<b>Bulb incl.</b>	No
<b>Class</b>	II
<b>Voltage (V/Hz)</b>	100V-240V/50-60Hz
<b>Cable</b>	2 MT

**Mine Glass Space 2L**  
Nahrang



- 28375-2L  Matt White
- 28376-2L  Dark Grey

<b>Material</b>	<b>Body</b> Aluminium+Wood
	<b>Diff</b> Glass
<b>Light Source</b>	2 E27 max. 15W
<b>Bulb incl.</b>	No
<b>Class</b>	II
<b>Voltage (V/Hz)</b>	100V-240V/50-60Hz
<b>Cable</b>	4 MT

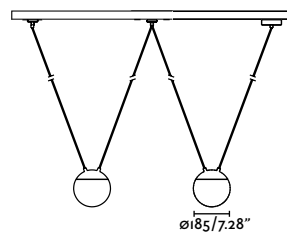
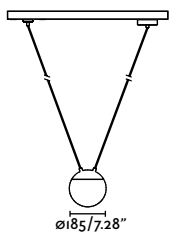
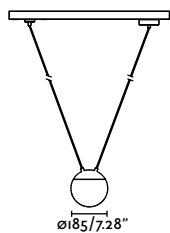



indoor

Suspended



**Mine PC Space 2L**  
Nahtrang



- 28209-2L  Matt White
- 28210-2L  Dark Grey

<b>Material</b>	<b>Body</b> Aluminium+Wood
	<b>Diff</b> PC
<b>Light Source</b>	2 E27 max. 15W
<b>Bulb incl.</b>	No
<b>Class</b>	II
<b>Voltage (V/Hz)</b>	100V-240V/50-60Hz
<b>Cable</b>	4 MT

**Mine Glass Space 3L**  
Nahtrang



- 28375-3L  Matt White
- 28376-3L  Dark Grey

<b>Material</b>	<b>Body</b> Aluminium+Wood
	<b>Diff</b> Glass
<b>Light Source</b>	3 E27 max. 15W
<b>Bulb incl.</b>	No
<b>Class</b>	II
<b>Voltage (V/Hz)</b>	100V-240V/50-60Hz
<b>Cable</b>	6 MT

**Mine PC Space 3L**  
Nahtrang



- 28209-3L  Matt White
- 28210-3L  Dark Grey

<b>Material</b>	<b>Body</b> Aluminium+Wood
	<b>Diff</b> PC
<b>Light Source</b>	3 E27 max. 15W
<b>Bulb incl.</b>	No
<b>Class</b>	II
<b>Voltage (V/Hz)</b>	100V-240V/50-60Hz
<b>Cable</b>	6 MT

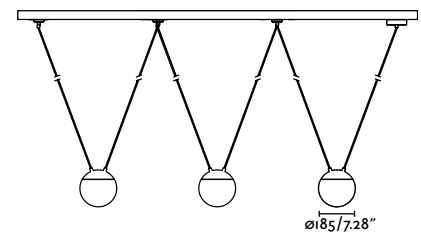
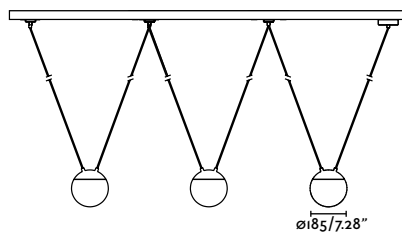
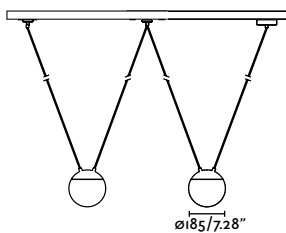



indoor

Suspended



Mine PC Space 3L Ref. 28376-3L  
Thanks to DOS architects Tavis Wright | Photo by Tomeu Canyellas

## Mine Glass Space 4L

Nahträng



- 28375-4L  Matt White
- 28376-4L  Dark Grey

<b>Material</b>	<b>Body</b> Aluminium+Wood
	<b>Diff</b> Opal Glass
<b>Light Source</b>	4 E27 max. 15W
<b>Bulb incl.</b>	No
<b>Class</b>	II
<b>Voltage (V/Hz)</b>	100V-240V/50-60Hz
<b>Cable</b>	8 MT

## Mine PC Space 4L

Nahträng



- 28209-4L  Matt White
- 28210-4L  Dark Grey

<b>Material</b>	<b>Body</b> Aluminium+Wood
	<b>Diff</b> Opal PC
<b>Light Source</b>	4 E27 max. 15W
<b>Bulb incl.</b>	No
<b>Class</b>	II
<b>Voltage (V/Hz)</b>	100V-240V/50-60Hz
<b>Cable</b>	8 MT

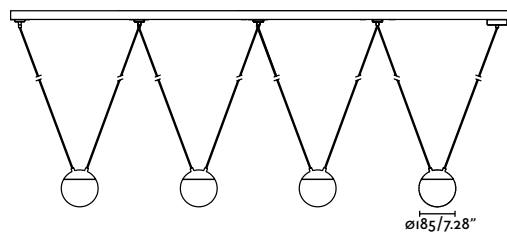
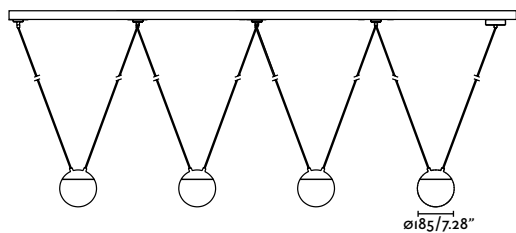



indoor

Suspended



**Mine Glass Space 5L**  
Nahträng



- 28375-5L  Matt White
- 28376-5L  Dark Grey

<b>Material</b>	<b>Body</b> Aluminium+Wood
	<b>Diff</b> Opal Glass
<b>Light Source</b>	5 E27 max. 15W
<b>Bulb incl.</b>	No
<b>Class</b>	II
<b>Voltage (V/Hz)</b>	100V-240V/50-60Hz
<b>Cable</b>	10 MT

**Mine PC Space 5L**  
Nahträng



- 28209-5L  Matt White
- 28210-5L  Dark Grey

<b>Material</b>	<b>Body</b> Aluminium+Wood
	<b>Diff</b> Opal PC
<b>Light Source</b>	5 E27 max. 15W
<b>Bulb incl.</b>	No
<b>Class</b>	II
<b>Voltage (V/Hz)</b>	100V-240V/50-60Hz
<b>Cable</b>	10 MT



**Hook accessory**  
28373  Matt White



**Hook accessory**  
28374  Dark Grey

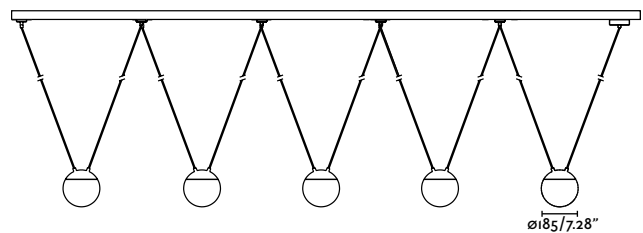
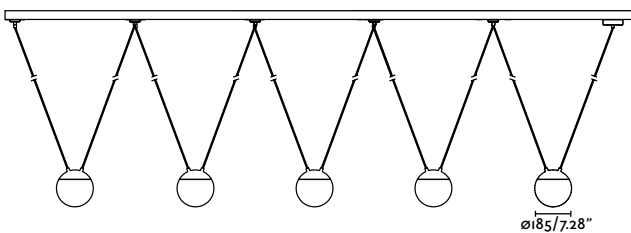

**Tell us your needs and we will make it happen**

Send your demand on [customize@faro.es](mailto:customize@faro.es)



indoor

Suspended



**Cocotte 430**  
Jordi Llopis



- 64262-110  Shiny White
- 64263-110  Shiny Black

<b>Material</b>	<b>Body</b> Aluminium <b>Diff</b> Opal PMMA
<b>Power</b>	30W
<b>Lumen Output</b>	1300lm
<b>Light Source</b>	SMD LED 3000K
<b>Class</b>	I
<b>CRI</b>	>80
<b>Voltage (V/Hz)</b>	110V/50-60Hz
<b>Cable</b>	1.1 MT

**Cocotte 550**  
Jordi Llopis



- 64261  Shiny Black

<b>Material</b>	<b>Body</b> Aluminium <b>Diff</b> Opal PMMA
<b>Power</b>	38W
<b>Lumen Output</b>	1700lm
<b>Light Source</b>	SMD LED 3000K
<b>Class</b>	I
<b>CRI</b>	>80
<b>Voltage (V/Hz)</b>	100V-240V/50-60Hz
<b>Cable</b>	1.1 MT

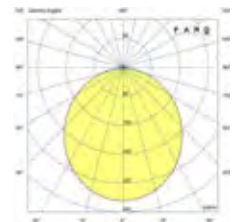
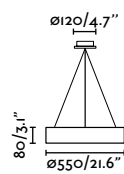
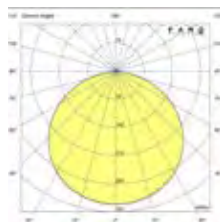
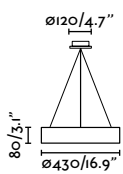

indoor

Suspended

# Cocotte

Designed by Jordi Llopis



Cocotte 550 Ref. 64261

**Kombo 120**  
Nutcreatives



- 68591-1L   Matt Black + Grey
- 68592-1L   Matt Black + Beige

**Kombo 200**  
Nutcreatives



- 68593-1L   Matt Black + Grey
- 68594-1L   Matt Black + Beige

**Kombo 400**  
Nutcreatives



- 68595-1L   Matt Black + Grey
- 68596-1L   Matt Black + Beige
- 68597-1L   Matt Black + Terracotta

<b>Material</b>	<b>Body Steel</b>
<b>Light Source</b>	1 E27 max. 15W
<b>Bulb incl.</b>	No
<b>Class</b>	II
<b>Voltage (V/Hz)</b>	100V-240V/50-60Hz
<b>Cable</b>	1.5 MT

<b>Material</b>	<b>Body Steel</b>
<b>Light Source</b>	1 E27 max. 15W
<b>Bulb incl.</b>	No
<b>Class</b>	II
<b>Voltage (V/Hz)</b>	100V-240V/50-60Hz
<b>Cable</b>	1.5 MT

<b>Material</b>	<b>Body Steel</b>
<b>Light Source</b>	1 E27 max. 15W
<b>Bulb incl.</b>	No
<b>Class</b>	II
<b>Voltage (V/Hz)</b>	100V-240V/50-60Hz
<b>Cable</b>	1.5 MT

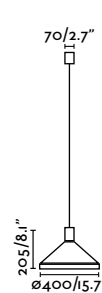
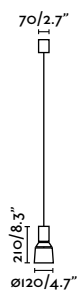



indoor

Suspended

# Kombo

Designed by Nutcreatives



Kombo 120 Ref. 68591-1L

223



## Naos 233

Àlex & Manel Lluscà



64500

● Beige + Terracotta

<b>Material</b>	<b>Body</b> Steel+Glass
	<b>Diff</b> Opal Glass
	<b>Shade</b> Steel
<b>Light Source</b>	1 E27 max. 15W
<b>Bulb incl.</b>	No
<b>Class</b>	I
<b>Voltage (V/Hz)</b>	100V-240V/50-60Hz
<b>Cable</b>	1.8 MT

## Naos 400

Àlex & Manel Lluscà



64501

● Beige + Terracotta

<b>Material</b>	<b>Body</b> Steel+Glass
	<b>Diff</b> Opal Glass
	<b>Shade</b> Steel
<b>Light Source</b>	1 E27 max. 15W
<b>Bulb incl.</b>	No
<b>Class</b>	I
<b>Voltage (V/Hz)</b>	100V-240V/50-60Hz
<b>Cable</b>	1.8 MT

Two-colour ring accessory incl.

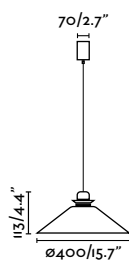
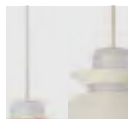

indoor

Suspended

# Naos

Designed by Àlex & Manel Llusçà



---

**Side 200**

Àlex &amp; Manel Llusçà



62139

 Matt Black + Satin Copper

---

<b>Material</b>	<b>Body</b> Steel
	<b>Diff</b> Opal Glass
<b>Light Source</b>	1 G9 max. 6W
<b>Bulb incl.</b>	No
<b>Class</b>	II
<b>Voltage (V/Hz)</b>	100V-240V/50-60Hz
<b>Cable</b>	1.5 MT

---

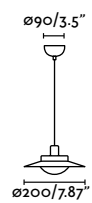

# Side

Designed by Àlex & Manel Lluscà

indoor

Suspended



**Costas 600**  
Àlex & Manel Llusçà



68590-69 ●● Matt Black + Rattan

<b>Material</b>	<b>Body Steel</b>
	<b>Shade Rattan</b>
<b>Light Source</b>	1 E27 max. 15W
<b>Bulb incl.</b>	No
<b>Class</b>	II
<b>Voltage (V/Hz)</b>	100V-240V/50-60Hz
<b>Cable</b>	1.5 MT

**Costas 1000**  
Àlex & Manel Llusçà



68590-70 ●● Matt Black + Rattan

<b>Material</b>	<b>Body Steel</b>
	<b>Shade Rattan</b>
<b>Light Source</b>	1 E27 max. 15W
<b>Bulb incl.</b>	No
<b>Class</b>	II
<b>Voltage (V/Hz)</b>	100V-240V/50-60Hz
<b>Cable</b>	1.5 MT

Hook accessory incl.



Wall  
358

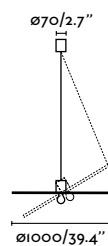
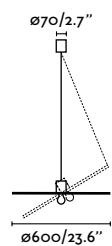



# Costas

Designed by Àlex & Manel Lluscà



It is handmade, which reduces the impact on the planet.

It brings a Mediterranean touch to the space where you place it.



Costas 600 Ref. 68590-69

**Saipan**  
Faro Lab



65134-76 ●● Black + Rattan

**Tupai**  
Faro Lab



65134-77 ●● Black + Rattan

**Sumba**  
Faro Lab



65134-72 ●● Black + Rattan

<b>Material</b>	<b>Body Steel</b>
	<b>Shade Rattan</b>
<b>Light Source</b>	1 E27 max. 15W
<b>Bulb incl.</b>	No
<b>Class</b>	I
<b>Voltage (V/Hz)</b>	100V-240V/50-60Hz
<b>Cable</b>	2 MT

<b>Material</b>	<b>Body Steel</b>
	<b>Shade Rattan</b>
<b>Light Source</b>	1 E27 max. 15W
<b>Bulb incl.</b>	No
<b>Class</b>	I
<b>Voltage (V/Hz)</b>	100V-240V/50-60Hz
<b>Cable</b>	2 MT

<b>Material</b>	<b>Body Steel</b>
	<b>Shade Rattan</b>
<b>Light Source</b>	1 E27 max. 15W
<b>Bulb incl.</b>	No
<b>Class</b>	I
<b>Voltage (V/Hz)</b>	100V-240V/50-60Hz
<b>Cable</b>	2 MT



**Table**  
110



**Wall**  
386

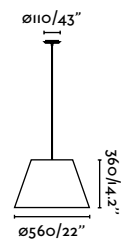
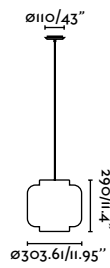

indoor

Suspended

# Saipan, Tupai & Sumba

Designed by Faro Lab



Tupai Ref. 65134-77



Sumba Ref. 65134-72

**Haka 250**  
Faro Lab



65134-73 ●● Black + Rattan

**Haka 300**  
Faro Lab



65134-74 ●● Black + Rattan

**Haka 530**  
Faro Lab



65134-75 ●● Black + Rattan

<b>Material</b>	<b>Body</b> Steel
	<b>Shade</b> Rattan
<b>Light Source</b>	1 E27 max. 15W
<b>Bulb incl.</b>	No
<b>Class</b>	I
<b>Voltage (V/Hz)</b>	100V-240V/50-60Hz
<b>Cable</b>	2 MT

<b>Material</b>	<b>Body</b> Steel
	<b>Shade</b> Rattan
<b>Light Source</b>	1 E27 max. 15W
<b>Bulb incl.</b>	No
<b>Class</b>	I
<b>Voltage (V/Hz)</b>	100V-240V/50-60Hz
<b>Cable</b>	2 MT

<b>Material</b>	<b>Body</b> Steel
	<b>Shade</b> Rattan
<b>Light Source</b>	1 E27 max. 15W
<b>Bulb incl.</b>	No
<b>Class</b>	I
<b>Voltage (V/Hz)</b>	100V-240V/50-60Hz
<b>Cable</b>	2 MT

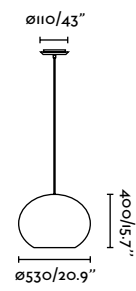
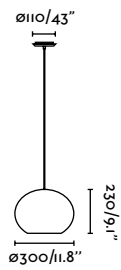
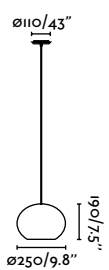

indoor

Suspended

# Haka

Designed by Faro Lab



Haka 530 Ref. 65134-75





**Mambo 210**  
Faro Lab



64315-47 Matt Black + Rattan

**Mambo 320**  
Faro Lab



64315-48 Matt Black + Rattan

**Mambo 450**  
Faro Lab



64315-49 Matt Black + Rattan

<b>Material</b>	<b>Body Steel</b>
	<b>Shade Rattan</b>
<b>Light Source</b>	1 E27 max. 15W
<b>Bulb incl.</b>	No
<b>Class</b>	II
<b>Voltage (V/Hz)</b>	100V-240V/50-60Hz
<b>Cable</b>	1.7 MT

<b>Material</b>	<b>Body Steel</b>
	<b>Shade Rattan</b>
<b>Light Source</b>	1 E27 max. 15W
<b>Bulb incl.</b>	No
<b>Class</b>	II
<b>Voltage (V/Hz)</b>	100V-240V/50-60Hz
<b>Cable</b>	1.7 MT

<b>Material</b>	<b>Body Steel</b>
	<b>Shade Rattan</b>
<b>Light Source</b>	1 E27 max. 15W
<b>Bulb incl.</b>	No
<b>Class</b>	II
<b>Voltage (V/Hz)</b>	100V-240V/50-60Hz
<b>Cable</b>	1.7 MT



**Table&Floor**  
136



**Wall**  
388

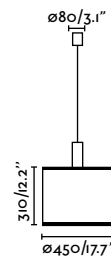
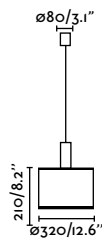
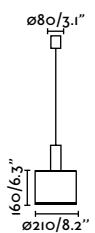

\*Structures and shades also sold separately 1406-1409

indoor

Suspended

# Mambo

Designed by Faro Lab



Mambo 450 Ref. 64315-49

**Mambo 210 displaced canopy**  
Faro Lab



64314-47 Matt Black + Rattan

**Mambo 320 displaced canopy**  
Faro Lab



64314-48 Matt Black + Rattan

**Mambo 450 displaced canopy**  
Faro Lab



64314-49 Matt Black + Rattan

<b>Material</b>	<b>Body Steel</b>
	<b>Shade Rattan</b>
<b>Light Source</b>	1 E27 max. 15W
<b>Bulb incl.</b>	No
<b>Class</b>	II
<b>Voltage (V/Hz)</b>	100V-240V/50-60Hz
<b>Cable</b>	1.5 MT

<b>Material</b>	<b>Body Steel</b>
	<b>Shade Rattan</b>
<b>Light Source</b>	1 E27 max. 15W
<b>Bulb incl.</b>	No
<b>Class</b>	II
<b>Voltage (V/Hz)</b>	100V-240V/50-60Hz
<b>Cable</b>	1.5 MT

<b>Material</b>	<b>Body Steel</b>
	<b>Shade Rattan</b>
<b>Light Source</b>	1 E27 max. 15W
<b>Bulb incl.</b>	No
<b>Class</b>	II
<b>Voltage (V/Hz)</b>	100V-240V/50-60Hz
<b>Cable</b>	1.5 MT

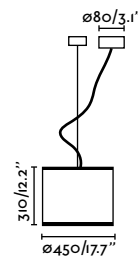
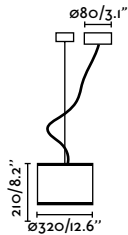
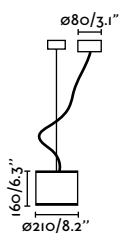

\*Structures and shades also sold separately 1406-1409

indoor

Suspended

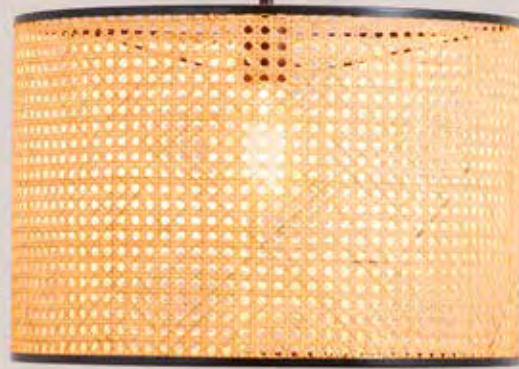



**Samba**  
Faro Lab



- 64315-44  Matt Black + Beige
- 64315-45  Matt Black + Yellow
- 64315-46  Matt Black + Green

<b>Material</b>	<b>Body</b> Steel
	<b>Diff</b> Papyrus
	<b>Shade</b> Textile
<b>Light Source</b>	1 E27 max. 15W
<b>Bulb incl.</b>	No
<b>Class</b>	II
<b>Voltage (V/Hz)</b>	100V-240V/50-60Hz
<b>Cable</b>	1.7 MT

**Samba displaced canopy**  
Faro Lab



- 64314-44  Matt Black + Beige
- 64314-45  Matt Black + Yellow
- 64314-46  Matt Black + Green

<b>Material</b>	<b>Body</b> Steel
	<b>Diff</b> Papyrus
	<b>Shade</b> Textile
<b>Light Source</b>	1 E27 max. 15W
<b>Bulb incl.</b>	No
<b>Class</b>	II
<b>Voltage (V/Hz)</b>	100V-240V/50-60Hz
<b>Cable</b>	1.5 MT



**Table&Floor**  
138



**Wall**  
380

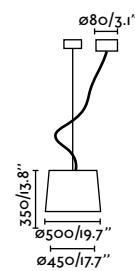
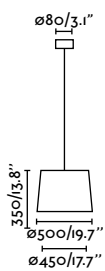

\*Structures and shades also sold separately 1406-1409



indoor

Suspended

# Samba

Designed by Faro Lab



Samba Ref. 64315-45

**Conga**  
Faro Lab



- 64315-54   Matt Black + White
- 64315-55   Matt Black + Beige
- 64315-56   Matt Black + Black

<b>Material</b>	<b>Body</b> Steel
	<b>Diff</b> Papyrus
	<b>Shade</b> Textile
<b>Light Source</b>	1 E27 max. 15W
<b>Bulb incl.</b>	No
<b>Class</b>	II
<b>Voltage (V/Hz)</b>	100V-240V/50-60Hz
<b>Cable</b>	1.7 MT

**Conga displaced canopy**  
Faro Lab



- 64314-54   Matt Black + White
- 64314-55   Matt Black + Beige
- 64314-56   Matt Black + Black

<b>Material</b>	<b>Body</b> Steel
	<b>Diff</b> Papyrus
	<b>Shade</b> Textile
<b>Light Source</b>	1 E27 max. 15W
<b>Bulb incl.</b>	No
<b>Class</b>	II
<b>Voltage (V/Hz)</b>	100V-240V/50-60Hz
<b>Cable</b>	1.5 MT



**Table&Floor**  
140



**Wall**  
384

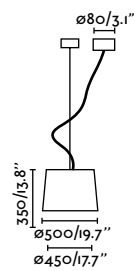
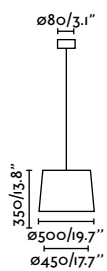

\*Structures and shades also sold separately 1406-1409

indoor

Suspended

# Conga

Designed by Faro Lab



Conga Ref. 64315-56

**Savoy**  
Isaac Piñeiro



- 20308-89  White + White
- 20309-90  Black + Black
- 20309-91  Black + Green

<b>Material</b>	<b>Body</b> Steel
	<b>Diff</b> Opal PMMA
	<b>Shade</b> Textile
<b>Light Source</b>	1 E27 max. 15W
<b>Bulb incl.</b>	No
<b>Class</b>	II
<b>Voltage (V/Hz)</b>	100V-240V/50-60Hz
<b>Cable</b>	0.8 MT

**Fusta**  
Àlex & Manel Llusçà



- 28394  Matt White + White

<b>Material</b>	<b>Body</b> Steel+Wood
	<b>Shade</b> Textile
<b>Light Source</b>	1 E27 max. 15W
<b>Bulb incl.</b>	No
<b>Class</b>	I
<b>Voltage (V/Hz)</b>	100V-240V/50-60Hz
<b>Cable</b>	1.7 MT

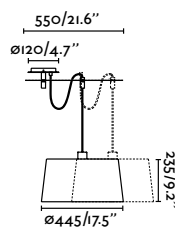
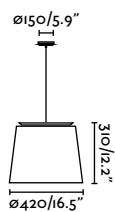

indoor

Suspended

# Fusta

Designed by Àlex & Manel Llusçà



Fusta Ref. 28394



**Vesper 400**  
Nahtrang



29988 ●● Matt White + Beige

<b>Material</b>	<b>Body</b> Steel
	<b>Diff</b> Opal PC
	<b>Shade</b> Textile
<b>Light Source</b>	3 E27 max. 15W
<b>Bulb incl.</b>	No
<b>Class</b>	I
<b>Voltage (V/Hz)</b>	100V-240V/50-60Hz
<b>Cable</b>	2 MT

**Vesper 600**  
Nahtrang



29986 ●● Matt White + Beige

<b>Material</b>	<b>Body</b> Steel
	<b>Diff</b> Opal PC
	<b>Shade</b> Textile
<b>Light Source</b>	2 E27 max. 15W
<b>Bulb incl.</b>	No
<b>Class</b>	I
<b>Voltage (V/Hz)</b>	100V-240V/50-60Hz
<b>Cable</b>	2 MT



**Table&Floor**  
152



**Wall**  
406

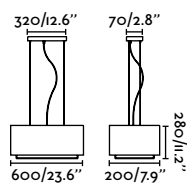
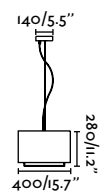

indoor

Suspended

# Vesper

Designed by Nahtrang

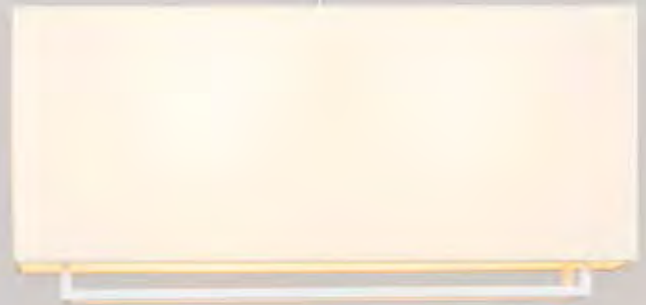

Vesper 600 Ref. 29986

**Hotel**  
Àlex & Manel Llusçà



**29944** ●● Matt White + White

**Linda**  
Estudi Ribaudí



**29309** ●● Matt White + Beige  
**29313** ●● Matt Black + Beige

**Tree**  
Estudi Ribaudí



**29864** ●● Matt Black + Black  
**29865** ●● Matt White + White

<b>Material</b>	<b>Body</b> Steel
	<b>Shade</b> Textile
<b>Light Source</b>	3 E27 max. 15W
<b>Bulb incl.</b>	No
<b>Class</b>	I
<b>Voltage (V/Hz)</b>	100V-240V/50-60Hz
<b>Cable</b>	1 MT

<b>Material</b>	<b>Body</b> Steel
	<b>Shade</b> Textile
<b>Light Source</b>	1 E27 max. 15W
<b>Bulb incl.</b>	No
<b>Class</b>	I
<b>Voltage (V/Hz)</b>	100V-240V/50-60Hz
<b>Cable</b>	1.2 MT

<b>Material</b>	<b>Body</b> Steel
	<b>Shade</b> Textile
<b>Light Source</b>	1 E27 max. 15W
<b>Bulb incl.</b>	No
<b>Class</b>	I
<b>Voltage (V/Hz)</b>	100V-240V/50-60Hz
<b>Cable</b>	1.3 MT

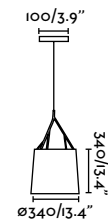
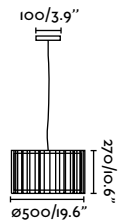
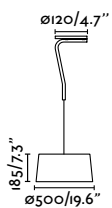
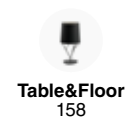
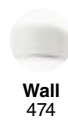

indoor

Suspended

# Hotel, Linda & Tree



Hotel Ref. 29944



Linda Ref. 29313



Tree Ref. 29864

## Crater



68461   Matt Black + Matt Gold

<b>Material</b>	<b>Body</b> Aluminium
<b>Light Source</b>	3 E27 max. 15W
<b>Bulb incl.</b>	No
<b>Class</b>	II
<b>Voltage (V/Hz)</b>	100V-240V/50-60Hz
<b>Cable</b>	1.5 MT

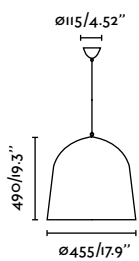

## Magma



28398   Matt White + Matt Silver  
 28399   Matt White + Matt Gold  
 29468   Black + Matt Gold

<b>Material</b>	<b>Body</b> Fiber glass
<b>Light Source</b>	3 E27 max. 15W
<b>Bulb incl.</b>	No
<b>Class</b>	I
<b>Voltage (V/Hz)</b>	100V-240V/50-60Hz
<b>Cable</b>	2 MT

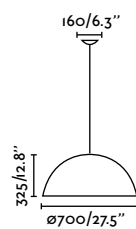



# Crater & Magma

indoor

Suspended



Magma Ref. 29468



Crater Ref. 68461

## Margot



- 68561  Matt Black + Wood  
 68564  Matt White + Wood

<b>Material</b>	<b>Body</b> Steel+Wood
<b>Light Source</b>	1 E27 max. 15W
<b>Bulb incl.</b>	No
<b>Class</b>	I
<b>Voltage (V/Hz)</b>	100V-240V/50-60Hz
<b>Cable</b>	1.2 MT

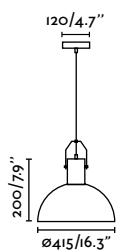

## Charlotte



- 68562  Dark Grey  
 68563  Matt White

<b>Material</b>	<b>Body</b> Steel
	<b>Diff</b> Opal PC
<b>Light Source</b>	1 E27 max. 15W
<b>Bulb incl.</b>	No
<b>Class</b>	I
<b>Voltage (V/Hz)</b>	100V-240V/50-60Hz
<b>Cable</b>	1.2 MT

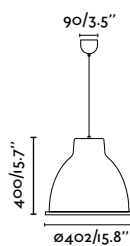

Margot

indoor

Suspended



Margot Ref. 68561

251

## Art



- 64137  Old Gold  
65134  Black

<b>Material</b>	Body Steel
<b>Light Source</b>	1 E27 max. 15W
<b>Bulb incl.</b>	No
<b>Class</b>	I
<b>Voltage (V/Hz)</b>	100V-240V/50-60Hz
<b>Cable</b>	1.5 MT

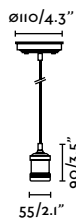

indoor

Suspended





## Rose



65082

● Matt Black

<b>Material</b>	<b>Body Steel</b>
	<b>Diff Transparent Glass</b>
<b>Light Source</b>	1 E27 max. 15W
<b>Bulb incl.</b>	No
<b>Class</b>	II
<b>Voltage (V/Hz)</b>	100V-240V/50-60Hz
<b>Cable</b>	1.5 MT

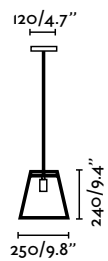

## Rose 4L



65081

● Matt Black

<b>Material</b>	<b>Body Steel</b>
	<b>Diff Transparent Glass</b>
<b>Light Source</b>	4 E27 max. 15W
<b>Bulb incl.</b>	No
<b>Class</b>	I
<b>Voltage (V/Hz)</b>	100V-240V/50-60Hz

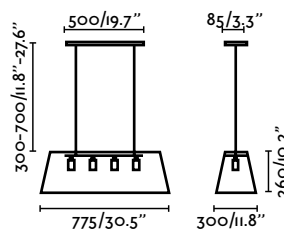

indoor

Suspended

# Rose



Rose Ref. 65082



Rose 4L Ref. 65081

## Clara



64128

● ● Matt Black + Transparent

<b>Material</b>	<b>Body</b> Steel
	<b>Shade</b> Glass
<b>Light Source</b>	1 E27 max. 15W
<b>Bulb incl.</b>	No
<b>Class</b>	I
<b>Voltage (V/Hz)</b>	100V-240V/50-60Hz
<b>Cable</b>	2 MT

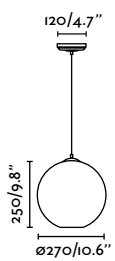

## Mou

350°



62806

● Shiny Black

<b>Material</b>	<b>Body</b> Steel
	<b>Shade</b> Steel
<b>Light Source</b>	1 E27 max. 15W
<b>Bulb incl.</b>	No
<b>Class</b>	I
<b>Voltage (V/Hz)</b>	100V-240V/50-60Hz
<b>Cable</b>	1.1 MT

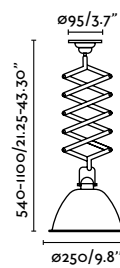

Mou

indoor

Suspended



## Halita



65071

● Old Gold + Transparent

<b>Material</b>	<b>Body</b> Steel+Glass
	<b>Shade</b> Glass
<b>Light Source</b>	1 E27 max. 15W
<b>Bulb incl.</b>	No
<b>Class</b>	I
<b>Voltage (V/Hz)</b>	100V-240V/50-60Hz
<b>Cable</b>	1.5 MT

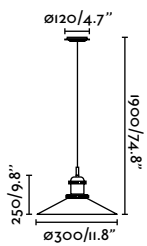

## Marlin



64133

● Old Gold + Black

<b>Material</b>	<b>Body</b> Steel
	<b>Shade</b> Steel
<b>Light Source</b>	1 E27 max. 15W
<b>Bulb incl.</b>	No
<b>Class</b>	I
<b>Voltage (V/Hz)</b>	100V-240V/50-60Hz
<b>Cable</b>	1.5 MT



**Wall**  
470

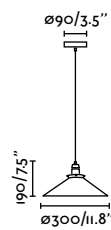



# Halita & Marlin

indoor

Suspended



Marlin Ref. 64133



Halita Ref. 65071

## Plat



- 68145  Matt Black
- 68146  Matt White

<b>Material</b>	Body Steel
<b>Light Source</b>	1 E27 max. 15W
<b>Bulb incl.</b>	No
<b>Class</b>	II
<b>Voltage (V/Hz)</b>	100V-240V/50-60Hz
<b>Cable</b>	1.5 MT

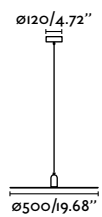

## Marina



- 60004  Matt Black

<b>Material</b>	Body Steel
	Diff Transparent Glass
<b>Light Source</b>	1 E27 max. 15W
<b>Bulb incl.</b>	No
<b>Class</b>	II
<b>Voltage (V/Hz)</b>	100V-240V/50-60Hz
<b>Cable</b>	1.5 MT

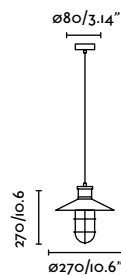

indoor

Suspended

# Plat



Plat Ref. 68145  
Thanks to SALTO Proyectos de Arquitectura | Photo by Architectural Matter

## Lou



- 62800 ● Shiny Black
- 62801 ● Shiny Green

<b>Material</b>	<b>Body Steel</b>
<b>Light Source</b>	1 E27 max. 15W
<b>Bulb incl.</b>	No
<b>Class</b>	I
<b>Voltage (V/Hz)</b>	100V-240V/50-60Hz
<b>Cable</b>	0.9 MT

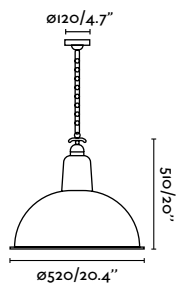

## Lang



- 62804 ● Shiny Black
- 62805 ● Shiny Green

<b>Material</b>	<b>Body Steel</b>
<b>Light Source</b>	1 E27 max. 15W
<b>Bulb incl.</b>	No
<b>Class</b>	I
<b>Voltage (V/Hz)</b>	100V-240V/50-60Hz
<b>Cable</b>	1.4 MT

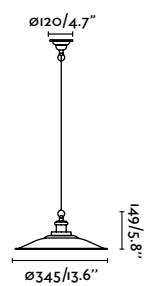

## Claire



- 62802 ● Shiny Black
- 62803 ● Shiny Green

<b>Material</b>	<b>Body Steel</b>
<b>Light Source</b>	1 E27 max. 15W
<b>Bulb incl.</b>	No
<b>Class</b>	I
<b>Voltage (V/Hz)</b>	100V-240V/50-60Hz
<b>Cable</b>	1.4 MT





# Claire

indoor

Suspended





## Liana



68569

● ● Black + Natural Hemp

<b>Material</b>	<b>Body</b> Steel
	<b>Shade</b> Hemp
<b>Light Source</b>	1 E27 max. 15W
<b>Bulb incl.</b>	No
<b>Class</b>	I
<b>Voltage (V/Hz)</b>	100V-240V/50-60Hz
<b>Cable</b>	1.2 MT

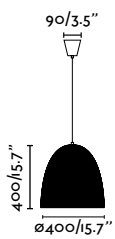

## Nido



68153

● ● Matt Black + Brown

<b>Material</b>	<b>Body</b> Steel
	<b>Shade</b> Cane
<b>Light Source</b>	1 E27 max. 15W
<b>Bulb incl.</b>	No
<b>Class</b>	I
<b>Voltage (V/Hz)</b>	100V-240V/50-60Hz
<b>Cable</b>	1.5 MT

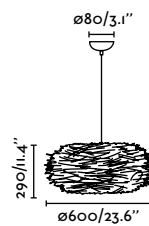

# Liana

indoor

Suspended



## Ora

incl.



- 29894  Matt White
- 29895  Matt Black

<b>Material</b>	<b>Body Aluminium</b>
	<b>Diff PMMA</b>
<b>Power</b>	4W
<b>Lumen Output</b>	350lm
<b>Light Source</b>	SMD LED 3000K
<b>Class</b>	II
<b>CRI</b>	>80
<b>Voltage (V/Hz)</b>	100V-240V/50-60Hz
<b>Beam angle</b>	°
<b>Cable</b>	1.5 MT

## Sabi

incl.



- 64321  Matt Black

<b>Material</b>	<b>Body Aluminium</b>
	<b>Diff PMMA</b>
<b>Power</b>	3W
<b>Lumen Output</b>	280lm
<b>Light Source</b>	SMD LED 2700K
<b>Class</b>	I
<b>CRI</b>	>80
<b>Voltage (V/Hz)</b>	100V-240V/50-60Hz
<b>Beam angle</b>	30°
<b>Cable</b>	1.2 MT

## Stan



- 43754  Matt White
- 43755  Matt Black
- 43756  Satin Gold

<b>Material</b>	<b>Body Aluminium</b>
<b>Light Source</b>	1 GU10 max. 5W
<b>Bulb incl.</b>	No
<b>Class</b>	I
<b>Voltage (V/Hz)</b>	100V-240V/50-60Hz
<b>Cable</b>	1.2 MT

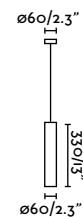
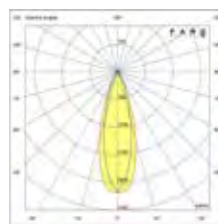
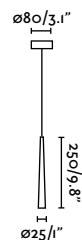
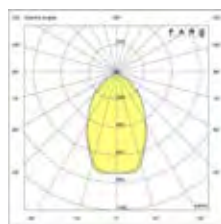
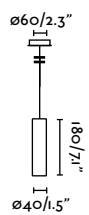

indoor

Suspended

# Ora



Ora Ref. 29895  
Thanks to Hernández Arquitectos | Photo by Maite Piera

## Cosmos

incl.

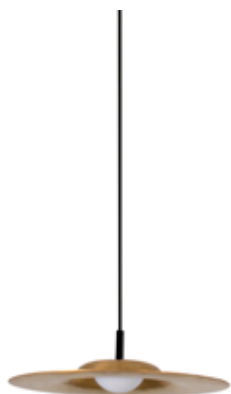

64224-110

● Bronze

<b>Material</b>	<b>Body</b> Aluminium+Steel
	<b>Diff</b> Opal Glass
<b>Power</b>	5W
<b>Lumen Output</b>	360lm
<b>Light Source</b>	SMD LED 3000K
<b>Class</b>	II
<b>CRI</b>	>80
<b>Voltage (V/Hz)</b>	110V/50-60Hz
<b>Beam angle</b>	180°
<b>Cable</b>	1.4 MT

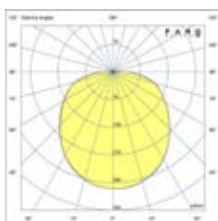



indoor

Suspended



# Danka

indoor

Suspended



Danka Ref. 64223  
Thanks to Puccio Collodoro Architetti | Photo by Puccio Collodoro Architetti

## Pam 165

incl.



- 64159-110 ● Matt White
- 64160-110 ● Black

<b>Material</b>	<b>Body Steel</b>
	<b>Diff Opal PMMA</b>
<b>Power</b>	11W
<b>Lumen Output</b>	900lm
<b>Light Source</b>	SMD LED 3000K
<b>Class</b>	II
<b>CRI</b>	>80
<b>Voltage (V/Hz)</b>	110V/50-60Hz
<b>Beam angle</b>	120°
<b>Cable</b>	1.5 MT

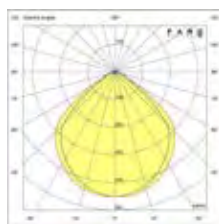
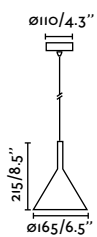

## Pam 250

incl.



- 64162-110 ●● Black + Matt Gold

<b>Material</b>	<b>Body Steel</b>
	<b>Diff Opal PMMA</b>
<b>Power</b>	24W
<b>Lumen Output</b>	1875lm
<b>Light Source</b>	SMD LED 3000K
<b>Class</b>	II
<b>CRI</b>	>80
<b>Voltage (V/Hz)</b>	110V/50-60Hz
<b>Beam angle</b>	120°
<b>Cable</b>	1.5 MT

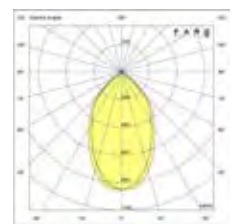
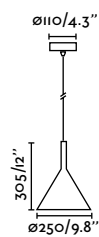

indoor

Suspended

# Pam



Pam 165 Ref. 64159-110  
Thanks to Distura Design

## Seven 400



68283

● Matt White

<b>Material</b>	<b>Body Steel</b>
	<b>Diff White Textile</b>
	<b>Shade Textile</b>
<b>Light Source</b>	2 E27 max. 15W
<b>Bulb incl.</b>	No
<b>Class</b>	I
<b>Voltage (V/Hz)</b>	100V-240V/50-60Hz
<b>Cable</b>	0.9 MT

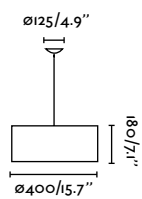

## Seven 500



68284

● Matt White

<b>Material</b>	<b>Body Steel</b>
	<b>Diff White Textile</b>
	<b>Shade Textile</b>
<b>Light Source</b>	3 E27 max. 15W
<b>Bulb incl.</b>	No
<b>Class</b>	I
<b>Voltage (V/Hz)</b>	100V-240V/50-60Hz
<b>Cable</b>	0.9 MT



**Ceiling**  
308

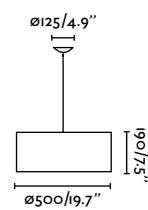



indoor

Suspended



# Installation solutions

Canopy recessed



Multiple light composition



Send your demand on [customize@faro.es](mailto:customize@faro.es)

# Multiple light composition

3 lights

5 lights

7 lights

## Kombo



68591-3L ● ●  
68592-3L ● ●

68591-5L ● ●  
68592-5L ● ●

68591-7L ● ●  
68592-7L ● ●



68593-3L ● ●  
68594-3L ● ●

68593-5L ● ●  
68594-5L ● ●

68593-7L ● ●  
68594-7L ● ●



68595-3L ● ●  
68596-3L ● ●  
68597-3L ● ●

68595-5L ● ●  
68596-5L ● ●  
68597-5L ● ●

68595-7L ● ●  
68596-7L ● ●  
68597-7L ● ●

## Mambo



64314-47-3L ● ●

64314-47-5L ● ●

64314-47-7L ● ●



64314-48-3L ● ●

64314-48-5L ● ●

64314-48-7L ● ●



64314-49-3L ● ●

64314-49-5L ● ●

64314-49-7L ● ●

3 lights

5 lights

7 lights

Conga



64314-54-3L ● ●  
64314-55-3L ● ●  
64314-56-3L ● ●

64314-54-5L ● ●  
64314-55-5L ● ●  
64314-56-5L ● ●

64314-54-7L ● ●  
64314-55-7L ● ●  
64314-56-7L ● ●

Samba

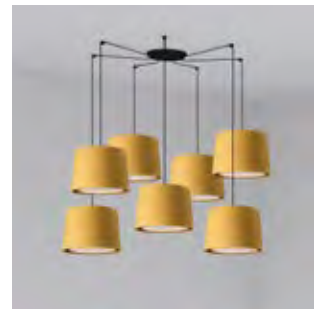

64314-44-3L ● ●  
64314-45-3L ● ●  
64314-46-3L ● ●

64314-44-5L ● ●  
64314-45-5L ● ●  
64314-46-5L ● ●

64314-44-7L ● ●  
64314-45-7L ● ●  
64314-46-7L ● ●

Retro



20046-3L ●  
20050-3L ●

20046-5L ●  
20050-5L ●

20046-7L ●  
20050-7L ●

Plat



68145-3L ●  
68146-3L ●

68145-5L ●  
68146-5L ●

68145-7L ●  
68146-7L ●

3 lights

5 lights

7 lights

Art



64135-3L ●  
64137-3L ●



64135-5L ●  
64137-5L ●



64135-7L ●  
64137-7L ●

Marlin



64133-3L ●



64133-5L ●



64133-7L ●

Clara



64128-3L ●



64128-5L ●



64128-7L ●

Claire



62802-3L ●  
62803-3L ●



62802-5L ●  
62803-5L ●



62802-7L ●  
62803-7L ●



3 lights

5 lights

7 lights

Lang



62804-3L ●  
62805-3L ●



62804-5L ●  
62805-5L ●



62804-7L ●  
62805-7L ●

Whizz



20160-3L ●  
20161-3L ●



20160-5L ●  
20161-5L ●

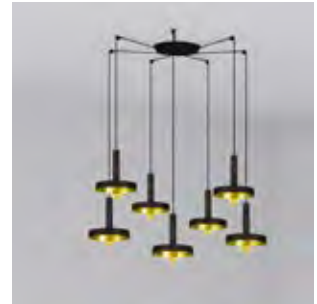

20160-7L ●  
20161-7L ●

Tatawin S



20340-116-3L ● ●  
20340-117-3L ● ●



20340-116-5L ● ●  
20340-117-5L ● ●



20340-116-7L ● ●  
20340-117-7L ● ●

Tatawin M



20340-119-3L ● ●  
20340-120-3L ● ●



20340-119-5L ● ●  
20340-120-5L ● ●



20340-119-7L ● ●  
20340-120-7L ● ●

indoor

Suspended

3 lights

5 lights

7 lights

Venice 160



- 64255-115-3L ●●●
- 64255-111-3L ●●○
- 64255-112-3L ●●●
- 64255-113-3L ●●●
- 64255-114-3L ●●●

- 64255-115-5L ●●●
- 64255-111-5L ●●○
- 64255-112-5L ●●●
- 64255-113-5L ●●●
- 64255-114-5L ●●●

- 64255-115-7L ●●●
- 64255-111-7L ●●○
- 64255-112-7L ●●●
- 64255-113-7L ●●●
- 64255-114-7L ●●●

Venice 200

NEW



- 64255-124-3L ●●○
- 64255-125-3L ●●●
- 64255-126-3L ●●●
- 64255-128-3L ●●●
- 64255-127-3L ●●●

- 64255-124-5L ●●○
- 64255-125-5L ●●●
- 64255-126-5L ●●●
- 64255-128-5L ●●●
- 64255-127-5L ●●●

- 64255-124-7L ●●○
- 64255-125-7L ●●●
- 64255-126-7L ●●●
- 64255-128-7L ●●●
- 64255-127-7L ●●●

# Canopy recessed

**With frame**



64231 ●

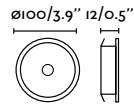

**Trimless**



64232

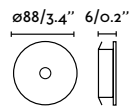

**Compatible in these situations**

<p>✓ Electrical wire+Turnbuckle</p>	<p>✓ Canopy with lamp holder E14   E27</p>	<p>✗ Canopy with turnbuckle</p>	<p>✗ Canopy with driver</p>
-------------------------------------	--	---------------------------------	-----------------------------

# Other solutions

**Hook**



68602 ●



**\*Track connector for suspension**

**Track**



- 64210A ●
- 64231A ●
- 64212A ●
- 64213A ●
- 64214A ●
- 64215A ●

\*Accessories compatible with all pendants with bulb and without turnbuckle.

Conga



68604-54 ●●



68604-55 ●●



68604-56 ●●

Samba



68604-44 ●●



68604-45 ●●



68604-46 ●●

Kombo



68604-62 ●●  
68604-63 ●●



68604-64 ●●  
68604-65 ●●



68604-66 ●●  
68604-67 ●●  
68604-68 ●●

Mambo



68604-47 ●●



68604-48 ●●



68604-49 ●●





# CEILING

**Amelia**  
Héctor Serrano

IP44



- 68610  Matt White
- 68611  Matt Black

<b>Material</b>	Body Steel
	Diff Opal White Glass
<b>Light Source</b>	1 E27 max. 15W
<b>Bulb incl.</b>	No
<b>Class</b>	II
<b>Voltage (V/Hz)</b>	100V-240V/50-60Hz

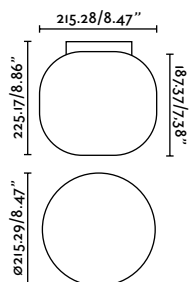

# Amelia NEW

Designed by Héctor Serrano

A calm lamp that  
blends into the space  
and at the same time  
delicately enriches it.



**Shoku 350**  
Ernest Perera Studio

incl. DIM TRIAC L



- 64277-110 ●● White + White
- 64278-110 ●● White + Black
- 64279-110 ●● Black + Black
- 64280-110 ●● Light Grey + White

<b>Material</b>	<b>Body</b> Aluminium
	<b>Diff</b> Opal White PMMA
<b>Power</b>	24W
<b>Lumen Output</b>	1213,4lm
<b>Light Source</b>	SMD LED 2700K
<b>Class</b>	II
<b>CRI</b>	>90
<b>Voltage (V/Hz)</b>	110V/50-60Hz

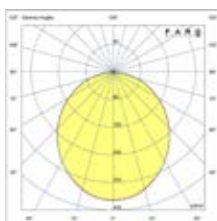
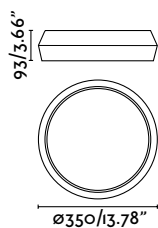

indoor

Ceiling

# Shoku

Designed by Ernest Perera Studio





**Shoku 600**  
Ernest Perera Studio

incl. DIM TRIAC L



- 64281-110 ●● White + White  
64282-110 ●● Black + Black

<b>Material</b>	<b>Body</b> Aluminium <b>Diff</b> Opal White PMMA
<b>Power</b>	40W
<b>Lumen Output</b>	2441.5lm
<b>Light Source</b>	SMD LED 2700K
<b>Class</b>	II
<b>CRI</b>	>90
<b>Voltage (V/Hz)</b>	110V/50-60Hz

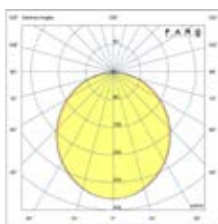
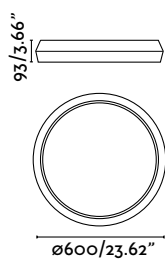

indoor

Ceiling



**Side 200**  
Àlex & Manel Llusçà



- 62132  Matt White
- 62133  Matt White + Satin Nickel
- 62134   Matt Black + Satin Gold
- 62135   Matt Black + Satin Copper

<b>Material</b>	<b>Body Steel</b>
	<b>Diff Glass</b>
<b>Light Source</b>	1 G9 max. 6W
<b>Bulb incl.</b>	No
<b>Class</b>	I
<b>Voltage (V/Hz)</b>	100V-240V/50-60Hz

**Side 390**  
Àlex & Manel Llusçà



- 62141-110   Matt White + Satin Nickel
- 62142-110   Matt Black + Satin Gold
- 62143-110   Matt Black + Satin Copper
- 62140-110  Matt White

<b>Material</b>	<b>Body Steel</b>
	<b>Diff Glass</b>
<b>Power</b>	15W
<b>Lumen Output</b>	1200lm
<b>Light Source</b>	SMD LED 3000K
<b>Class</b>	I
<b>CRI</b>	>80
<b>Voltage (V/Hz)</b>	110V/50-60Hz

**Side 450**  
Àlex & Manel Llusçà



- 62144-110  Matt White
- 62145-110  Matt White + Satin Nickel
- 62146-110   Matt Black + Satin Gold
- 62147-110   Matt Black + Satin Copper

<b>Material</b>	<b>Body Steel</b>
	<b>Diff Glass</b>
<b>Power</b>	20W
<b>Lumen Output</b>	1700lm
<b>Light Source</b>	SMD LED 3000K
<b>Class</b>	I
<b>CRI</b>	>80
<b>Voltage (V/Hz)</b>	110V/50-60Hz



**Suspended**  
226

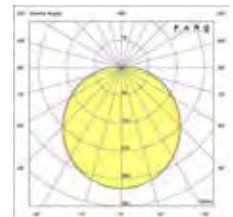
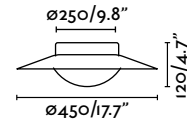
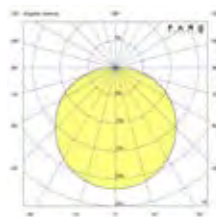
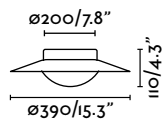
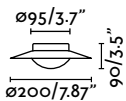

indoor

Ceiling

# Side

Designed by Àlex & Manel Llusçà

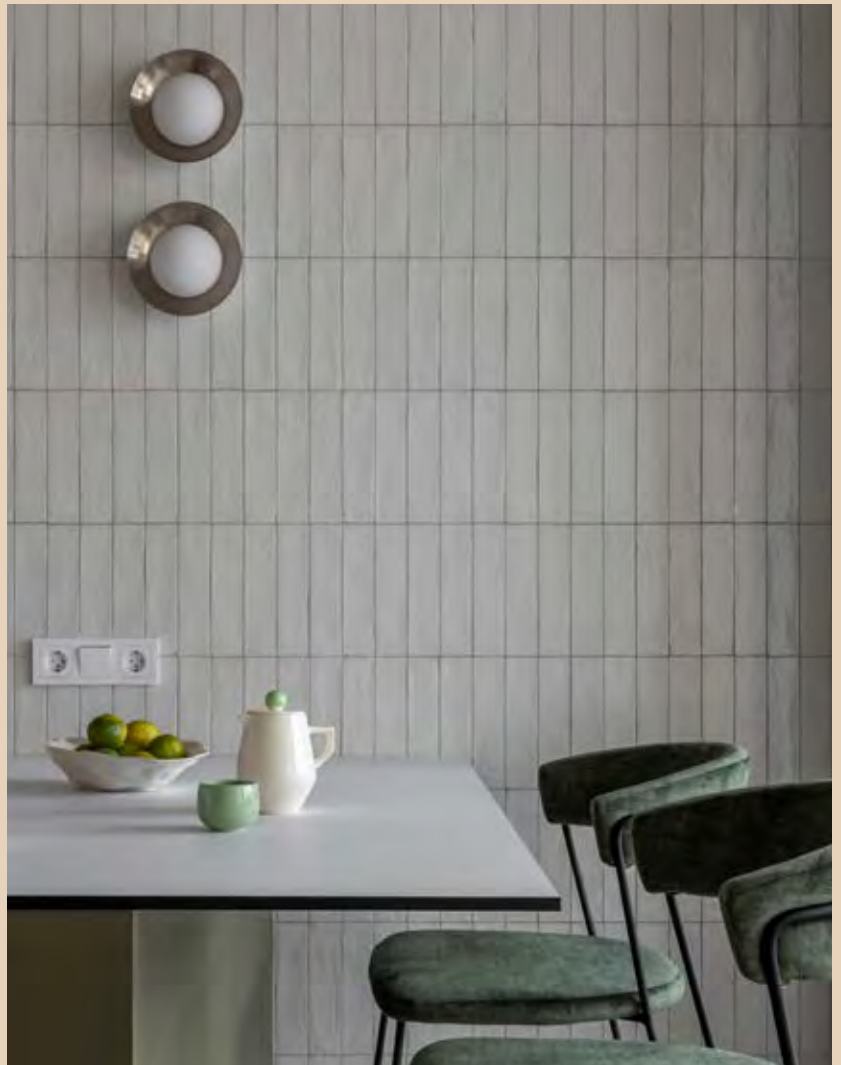

Side 200 Ref. 62133  
Thanks to Margarita Pavelka



Side 450 Ref. 62146-110

**Cocotte 430**  
Jordi Llopis



- 64250-110  Shiny White
- 64251-110  Shiny Black

<b>Material</b>	<b>Body</b> Aluminium
	<b>Diff</b> Opal PMMA
<b>Power</b>	30W
<b>Lumen Output</b>	1300lm
<b>Light Source</b>	SMD LED 3000K
<b>Class</b>	I
<b>CRI</b>	>80
<b>Voltage (V/Hz)</b>	110V/50-60Hz

**Cocotte 550**  
Jordi Llopis



- 64183  Shiny Black

<b>Material</b>	<b>Body</b> Aluminium
	<b>Diff</b> Opal PMMA
<b>Power</b>	38W
<b>Lumen Output</b>	1700lm
<b>Light Source</b>	SMD LED 3000K
<b>Class</b>	I
<b>CRI</b>	>80
<b>Voltage (V/Hz)</b>	100V-240V/50-60Hz

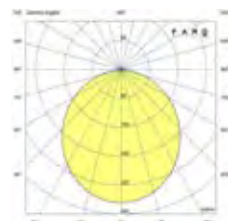
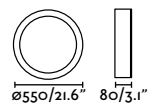
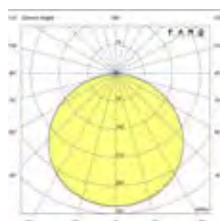
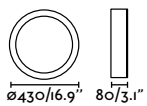



indoor

Ceiling

# Cocotte

Designed by Jordi Llopis



Cocotte 430 Ref. 64250-110



**Link**  
Estudi Ribaudí

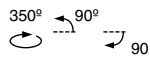

- 29877  Matt White
- 29878  Matt Black

**Orleans**  
Nahtrang



- 43529  Matt White
- 43531  Chrome + Matt Black

**Orleans 2L**  
Nahtrang

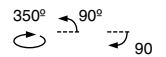

- 43534  Chrome + Matt Black

<b>Material</b>	Body Steel
<b>Light Source</b>	1 GU10 max. 8W
<b>Bulb incl.</b>	No
<b>Class</b>	I
<b>Voltage (V/Hz)</b>	100V-240V/50-60Hz

<b>Material</b>	Body Steel
<b>Light Source</b>	1 GU10 max. 8W
<b>Bulb incl.</b>	No
<b>Class</b>	I
<b>Voltage (V/Hz)</b>	100V-240V/50-60Hz

<b>Material</b>	Body Steel
<b>Light Source</b>	2 GU10 max. 8W
<b>Bulb incl.</b>	No
<b>Class</b>	I
<b>Voltage (V/Hz)</b>	100V-240V/50-60Hz



Spot  
520



Track  
564



Table&Floor  
130



Wall  
520



Spot  
518

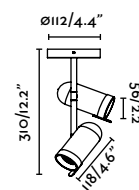
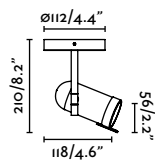
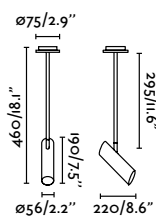

indoor

Ceiling

# Link

Designed by Estudi Ribaudí



Link Ref. 29877

## Tecto



- 63270  Matt White  
 63271  Matt Black

<b>Material</b>	<b>Body Aluminium</b>
<b>Light Source</b>	1 GU10 max. 8W
<b>Bulb incl.</b>	No
<b>Class</b>	I
<b>Voltage (V/Hz)</b>	100V-240V/50-60Hz

## Tecto 2L



- 63272  Matt White  
 63273  Matt Black

<b>Material</b>	<b>Body Aluminium</b>
<b>Light Source</b>	2 GU10 max. 8W
<b>Bulb incl.</b>	No
<b>Class</b>	I
<b>Voltage (V/Hz)</b>	100V-240V/50-60Hz

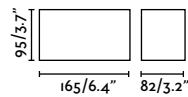
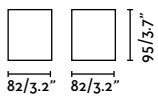

# Tecto

indoor

Ceiling



Tecto Ref. 63271

Thanks to SINCRO | Photo by Irene Diaz



## Tecto AR111

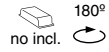

- 63274  Matt White
- 63275  Matt Black

<b>Material</b>	Body Aluminium
<b>Light Source</b>	1 G53 AR111 max. 15W
<b>Bulb incl.</b>	No
<b>Class</b>	III
<b>Voltage (V/Hz)</b>	100V-240V/50-60Hz

## Tecto 2L AR111

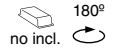

- 63276  Matt White
- 63277  Matt Black

<b>Material</b>	Body Aluminium
<b>Light Source</b>	2 G53 AR111 max. 30W
<b>Bulb incl.</b>	No
<b>Class</b>	III
<b>Voltage (V/Hz)</b>	100V-240V/50-60Hz

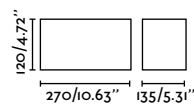
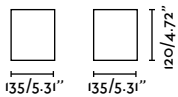



## Sven R



63268

● Matt White

<b>Material</b>	Body Plaster
<b>Light Source</b>	1 GU10 max. 8W
<b>Bulb incl.</b>	No
<b>Class</b>	I
<b>Voltage (V/Hz)</b>	100V-240V/50-60Hz

## Sven SQ



63269

● Matt White

<b>Material</b>	Body Plaster
<b>Light Source</b>	1 GU10 max. 8W
<b>Bulb incl.</b>	No
<b>Class</b>	I
<b>Voltage (V/Hz)</b>	100V-240V/50-60Hz

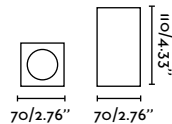
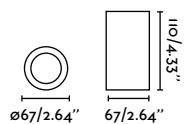

Sven

indoor

Ceiling



## Rel 75



- 64198-110  Matt White
- 64199-110  Matt Black

<b>Material</b>	<b>Body</b> Aluminium
	<b>Diff</b> Transparent Glass
<b>Power</b>	15W
<b>Lumen Output</b>	1340lm
<b>Light Source</b>	COB LED 2700K
<b>Class</b>	II
<b>CRI</b>	>80
<b>Voltage (V/Hz)</b>	110V/50-60Hz
<b>Beam angle</b>	60°

## Rel 100



- 64200-110  Matt White
- 64201-110  Matt Black

<b>Material</b>	<b>Body</b> Aluminium
	<b>Diff</b> Transparent Glass
<b>Power</b>	25W
<b>Lumen Output</b>	2230lm
<b>Light Source</b>	COB LED 2700K
<b>Class</b>	II
<b>CRI</b>	>80
<b>Voltage (V/Hz)</b>	110V/50-60Hz
<b>Beam angle</b>	60°

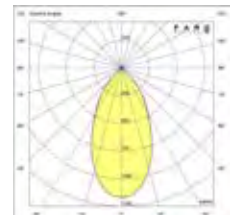
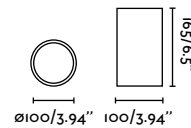
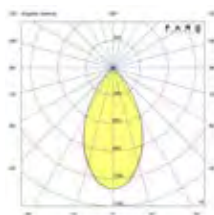
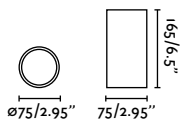



Rel

indoor

Ceiling



## Haru



- 64206  Matt White
- 64207  Matt Black

<b>Material</b>	<b>Body</b> Aluminium
	<b>Diff</b> Opal PMMA
<b>Power</b>	6W
<b>Lumen Output</b>	350lm
<b>Light Source</b>	SMD LED 3000K
<b>Class</b>	II
<b>CRI</b>	>80
<b>Voltage (V/Hz)</b>	100V-240V/50-60Hz
<b>Beam angle</b>	120°

## Natsu



- 64204-110  Matt White
- 64205-110  Matt Black

<b>Material</b>	<b>Body</b> Aluminium
	<b>Diff</b> Opal PMMA
<b>Power</b>	30W
<b>Lumen Output</b>	1500lm
<b>Light Source</b>	SMD LED 3000K
<b>Class</b>	II
<b>CRI</b>	>80
<b>Voltage (V/Hz)</b>	110V/50-60Hz
<b>Beam angle</b>	120°

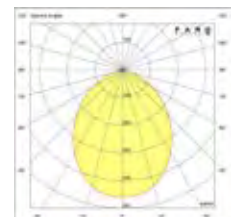
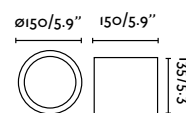
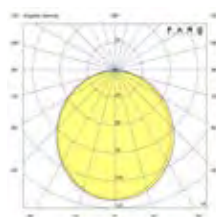
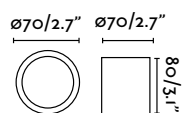

# Haru & Natsu



## Janet



65137 ● White

<b>Material</b>	Body Steel
<b>Light Source</b>	1 E27 max. 15W
<b>Bulb incl.</b>	No
<b>Class</b>	I
<b>Voltage (V/Hz)</b>	100V-240V/50-60Hz

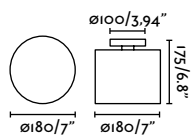

## Stan



43746 ● Matt White  
 43747 ● Matt Black  
 43758 ● Satin Gold  
 43764 ● Terracotta

<b>Material</b>	Body Aluminium
<b>Light Source</b>	1 GU10 max. 5W
<b>Bulb incl.</b>	No
<b>Class</b>	II
<b>Voltage (V/Hz)</b>	100V-240V/50-60Hz

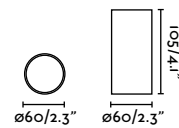

\*Accessories page 496



# Stan





---

## Pote



- 63124  Matt White  
63125  Matt Black

---

<b>Material</b>	<b>Body</b> Aluminium
<b>Light Source</b>	1 E27 max. 15W
<b>Bulb incl.</b>	No
<b>Class</b>	I
<b>Voltage (V/Hz)</b>	100V-240V/50-60Hz

---

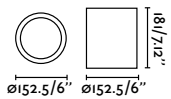

indoor

Ceiling



## Seven 400



68298

●● Matt White + White

<b>Material</b>	<b>Body</b> Steel
	<b>Diff</b> White Textile
	<b>Shade</b> Textile
<b>Light Source</b>	2 E27 max. 15W
<b>Bulb incl.</b>	No
<b>Class</b>	I
<b>Voltage (V/Hz)</b>	100V-240V/50-60Hz

## Seven 500



68317

●● Matt White + White

<b>Material</b>	<b>Body</b> Steel
	<b>Diff</b> White Textile
	<b>Shade</b> Textile
<b>Light Source</b>	3 E27 max. 15W
<b>Bulb incl.</b>	No
<b>Class</b>	I
<b>Voltage (V/Hz)</b>	100V-240V/50-60Hz



**Suspended**  
272

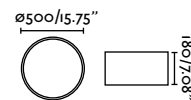
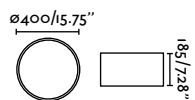

# Seven

indoor

Ceiling



Kao

IP44  incl.



63399

 Chrome

<b>Material</b>	<b>Body</b> Aluminium
	<b>Diff</b> Opal PMMA
<b>Power</b>	35W
<b>Lumen Output</b>	2800lm
<b>Light Source</b>	SMD LED 3000K
<b>Class</b>	II
<b>CRI</b>	>80
<b>Voltage (V/Hz)</b>	100V-240V/50-60Hz

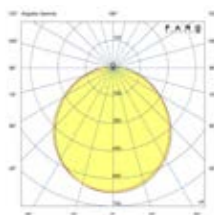
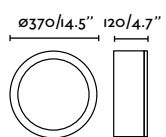





# Foro

IP44  incl. 



63404-110 ● Matt White

<b>Material</b>	<b>Body</b> Aluminium
	<b>Diff</b> Opal PMMA
<b>Power</b>	24W
<b>Lumen Output</b>	2000lm
<b>Light Source</b>	SMD LED 3000K
<b>Class</b>	II
<b>CRI</b>	>80
<b>Voltage (V/Hz)</b>	110V/50-60Hz

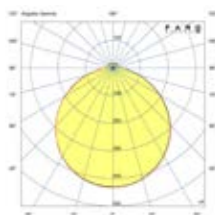
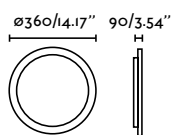

# Foro

indoor

Ceiling



## Logos 270

IP44



- 62965 ● Matt White
- 62980 ● Satin Nickel

<b>Material</b>	<b>Body</b> Aluminium
	<b>Diff</b> Opal PC
<b>Light Source</b>	1 E27 max. 15W
<b>Bulb incl.</b>	No
<b>Class</b>	II
<b>Voltage (V/Hz)</b>	100V-240V/50-60Hz

## Logos 350 2L

IP44



- 62966 ● Matt White
- 62981 ● Satin Nickel

<b>Material</b>	<b>Body</b> Aluminium
	<b>Diff</b> Opal PC
<b>Light Source</b>	2 E27 max. 15W
<b>Bulb incl.</b>	No
<b>Class</b>	II
<b>Voltage (V/Hz)</b>	100V-240V/50-60Hz

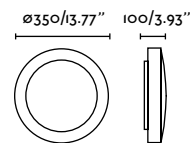
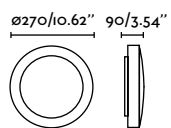

Logos

indoor

Ceiling





## Tola 270

IP44



62968

● Matt White

62983

● Satin Nickel

<b>Material</b>	<b>Body</b> Aluminium
	<b>Diff</b> Opal PC
<b>Light Source</b>	1 E27 max. 15W
<b>Bulb incl.</b>	No
<b>Class</b>	II
<b>Voltage (V/Hz)</b>	100V-240V/50-60Hz

## Tola 320

IP44



62969

● Matt White

<b>Material</b>	<b>Body</b> Aluminium
	<b>Diff</b> Opal PC
<b>Light Source</b>	2 E27 max. 15W
<b>Bulb incl.</b>	No
<b>Class</b>	II
<b>Voltage (V/Hz)</b>	100V-240V/50-60Hz

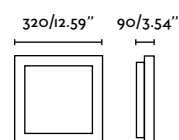
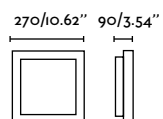

indoor

Ceiling





**INDOOR**

**LIGHTING**

# **SURFACE**

# Studio NEW

**Designed by** Nahtrang

Studio brings back lines of the 1950s and reinterprets them to fit into a modern context.



The main feature of its design that makes it unique is the way the cable is attached to the structure.



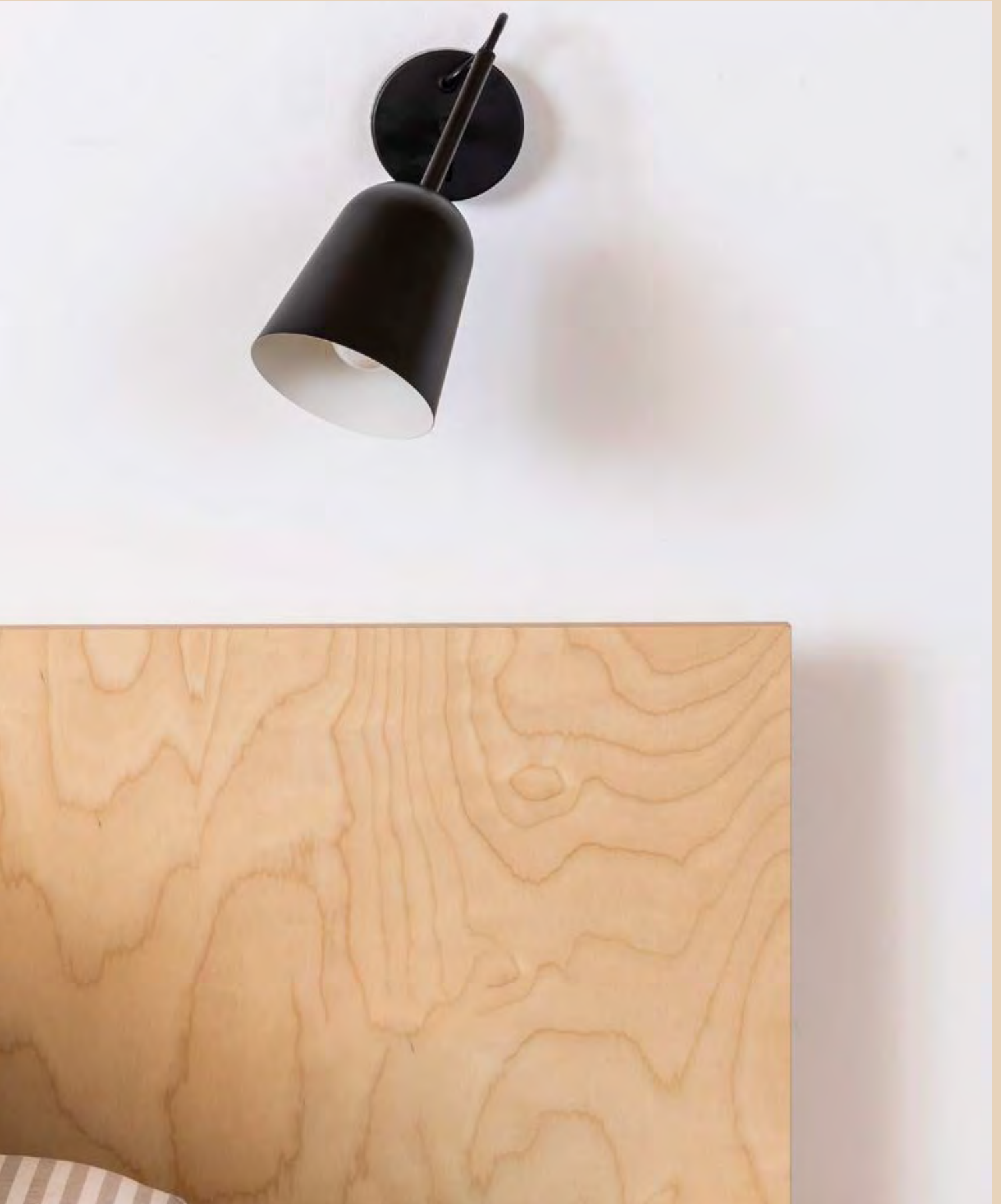

**Studio**  
Nahtrang

350°  
↻ ⏻



- 28257 ●● Matt Black + Black
- 28258 ●● Matt Black + White
- 28259 ●● Matt Black + Green
- 28274 ●● Matt Black + Blue
- 28275 ●● Matt Black + Pink

<b>Material</b>	<b>Body</b> Steel
	<b>Shade</b> Steel
<b>Light Source</b>	1 E14 max. 8W
<b>Bulb incl.</b>	No
<b>Class</b>	II
<b>Voltage (V/Hz)</b>	100V-240V/50-60Hz



**Suspended Table&Floor**  
178 72

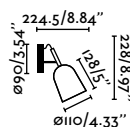

indoor

Surface



Studio Ref. 28274

325



# Dominica



**Designed by** Faro Lab

Its design of simple and friendly geometric shapes contrasts with its sober and industrial style.



Its shade is adjustable on the horizontal plane.







**Dominica**  
Faro Lab



- 20031-122 ●● Matt Black + Beige
- 20031-123 ●● Matt Black + Matt Black

**Dominica reader**  
Faro Lab



- 20032-122 ●● Matt Black + Beige
- 20032-123 ●● Matt Black + Matt Black

**Dominica XL**  
Faro Lab



- 20040-122 ●● Matt Black + Beige
- 20040-123 ●● Matt Black + Matt Black

<b>Material</b>	<b>Body Steel</b>
	<b>Shade Steel</b>
<b>Light Source</b>	1 E27 max. 15W
<b>Bulb incl.</b>	No
<b>Class</b>	II
<b>Voltage (V/Hz)</b>	100V-240V/50-60Hz

<b>Material</b>	<b>Body Steel</b>
	<b>Shade Steel</b>
<b>Light Source</b>	1 E27 max. 15W
<b>Bulb incl.</b>	No
<b>Reader</b>	1W, 3000K, 100lm
<b>Driver incl.</b>	Yes
<b>Class</b>	II
<b>Voltage (V/Hz)</b>	100V-240V/50-60Hz

<b>Material</b>	<b>Body Steel</b>
	<b>Shade Steel</b>
<b>Light Source</b>	1 E27 max. 15W
<b>Bulb incl.</b>	No
<b>Class</b>	II
<b>Voltage (V/Hz)</b>	100V-240V/50-60Hz
<b>Cable</b>	2.5 MT

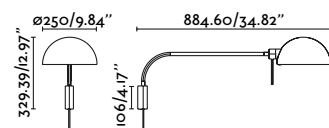
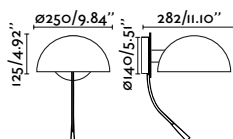
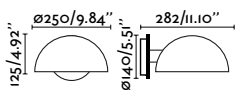

**Table&Floor**  
76

indoor

Surface





# Tatawin

**Designed by** Adolfo Abejón

Inspired by  
the houses  
of Tataouine,  
Tunisia.



Tatawin Ref. 20335-116



Its blown glass shade provides  
nostalgia and warmth.

**Tatawin**  
Adolfo Abejón

**Tatawin arm wall**  
Adolfo Abejón

150°  

NEW



- 20335-116  Satin Black + Opal
- 20335-117  Satin Black + Shiny Black

- 20342-116  Satin Black + Opal
- 20342-117  Satin Black + Shiny Black

<b>Material</b>	<b>Body</b> Aluminium
	<b>Shade</b> Glass
<b>Light Source</b>	1 E27 G45 max. 15W
<b>Bulb incl.</b>	No
<b>Class</b>	II
<b>Voltage (V/Hz)</b>	100V-240V/50-60Hz

<b>Material</b>	<b>Body</b> Steel
	<b>Shade</b> Glass
<b>Light Source</b>	1 E27 G45 max. 15W
<b>Bulb incl.</b>	No
<b>Class</b>	II
<b>Voltage (V/Hz)</b>	100V-240V/50-60Hz



**Suspended Table&Floor**  
186 80

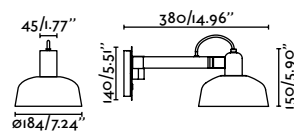
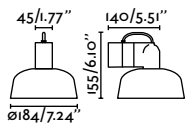





**Milo 280**  
Faro Lab



2 Installation Modes



63420

● White

<b>Material</b>	<b>Body Plaster</b>
	<b>Diff Opal PC</b>
<b>Light Source</b>	1 E14 max. 7W
<b>Bulb incl.</b>	No
<b>Class</b>	II
<b>Voltage (V/Hz)</b>	100V-240V/50-60Hz

**Milo 400**  
Faro Lab



2 Installation Modes



63421

● White

<b>Material</b>	<b>Body Plaster</b>
	<b>Diff Opal PC</b>
<b>Light Source</b>	2 E14 max. 7W
<b>Bulb incl.</b>	No
<b>Class</b>	II
<b>Voltage (V/Hz)</b>	100V-240V/50-60Hz

**Milo 500**  
Faro Lab

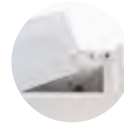

2 Installation Modes



63422

● White

<b>Material</b>	<b>Body Plaster</b>
	<b>Diff Opal PC</b>
<b>Light Source</b>	2 E14 max. 7W
<b>Bulb incl.</b>	No
<b>Class</b>	II
<b>Voltage (V/Hz)</b>	100V-240V/50-60Hz

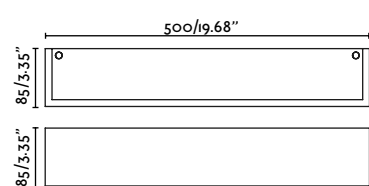
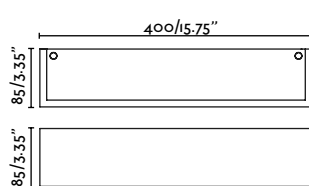
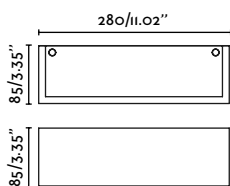

indoor

Surface

# Milo

NEW

Designed by Faro Lab

Architectural  
character to integrate  
in minimalist and  
elegant spaces.



# Liggera

350° 90°



20077

●● Matt Black + Matt Black

<b>Material</b>	<b>Body Steel</b>
	<b>Shade Steel</b>
<b>Light Source</b>	1 G9 max. 6W
<b>Bulb incl.</b>	No
<b>Class</b>	II
<b>Voltage (V/Hz)</b>	100V-240V/50-60Hz



Suspended Table&Floor  
196 94

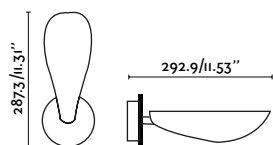

Liggera NEW

indoor

Surface



Its soft and natural forms are inspired by ancient Japanese minimalism.



Liggera Ref. 20077



# Luang

Designed by Faro Lab

Inspired by the Southeast Asian culture and its way of creating objects from paper art.



It is a design of proximity manufacturing: its structure is produced in Spain and its screen in Bulgaria.

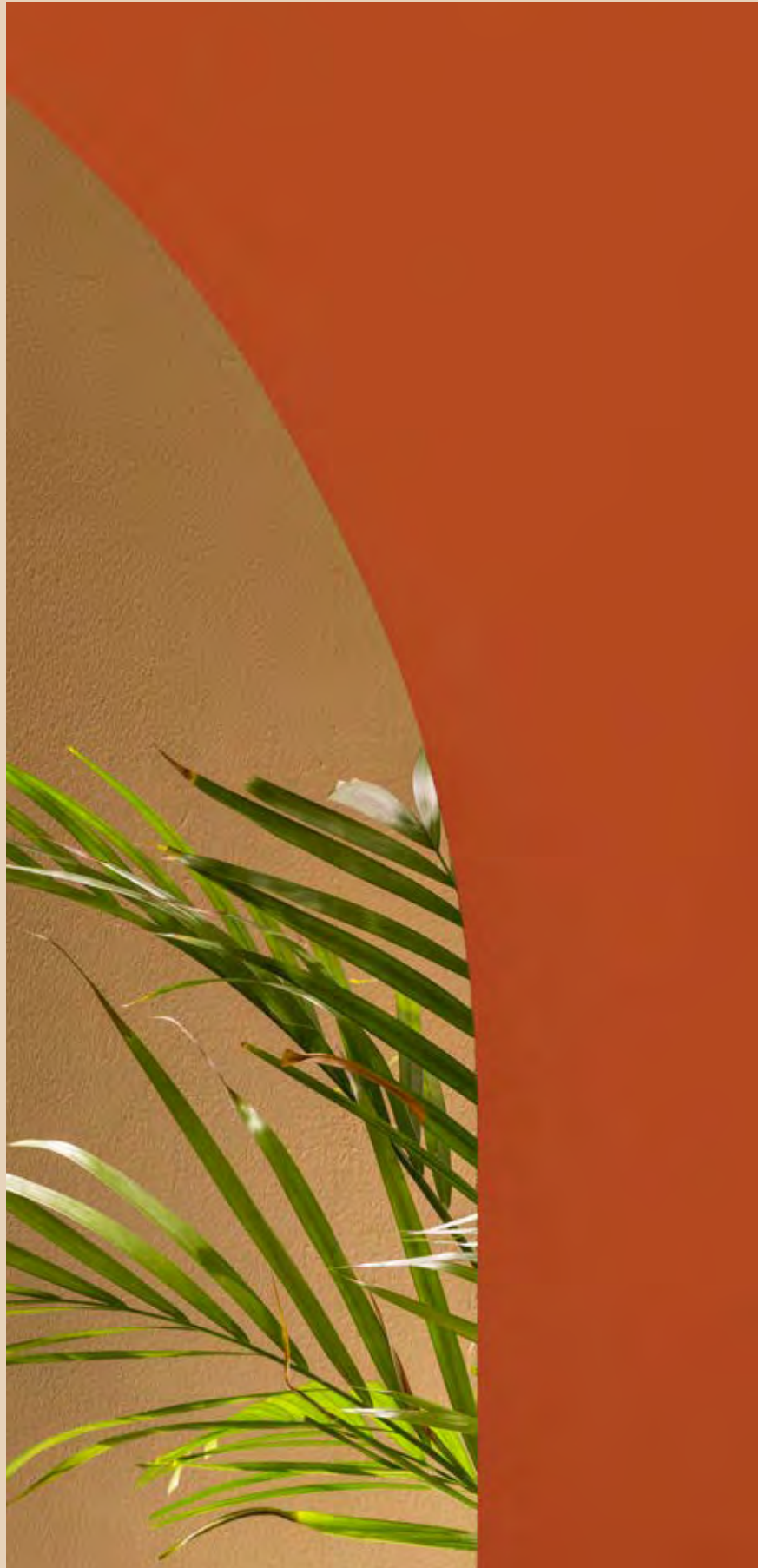



**Luang**  
Faro Lab

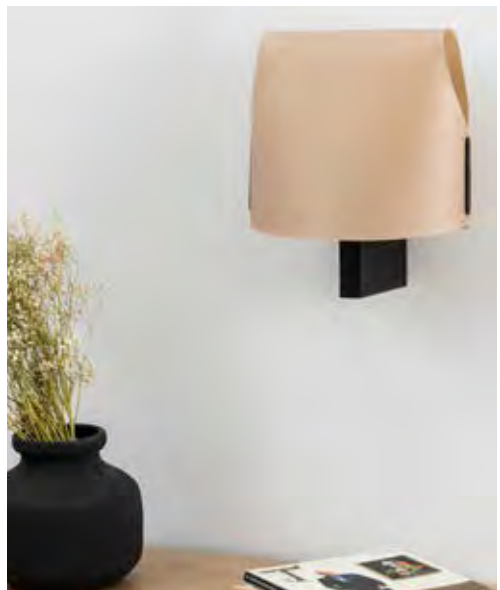

- 23004-57 ● Black + Beige
- 23004-58 ● Black + Camel

<b>Material</b>	<b>Body</b> Steel
	<b>Shade</b> Parchment
<b>Light Source</b>	1 E27 max. 15W
<b>Bulb incl.</b>	No
<b>Class</b>	I
<b>Voltage (V/Hz)</b>	100V-240V



**Table&Floor**  
90

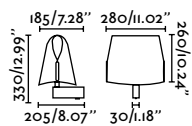

indoor

Surface



## Nila



20052

●● Matt Black + Off White

<b>Material</b>	<b>Body</b> Steel
	<b>Shade</b> Textile
<b>Light Source</b>	1 E27 max. 15W
<b>Bulb incl.</b>	No
<b>Class</b>	I
<b>Voltage (V/Hz)</b>	100V-240V/50-60Hz

## Nila reader



20053

●● Matt Black + Off White

<b>Material</b>	<b>Body</b> Steel
	<b>Shade</b> Textile
<b>Light Source</b>	1 E27 max. 15W
<b>Bulb incl.</b>	No
<b>Reader</b>	3W, 3000K, 280lm
<b>Driver incl.</b>	Yes
<b>Class</b>	I
<b>Voltage (V/Hz)</b>	100V-240V/50-60Hz



**Table&Floor**  
150

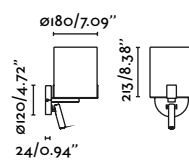
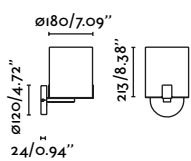



Nila

NEW

indoor

Surface



Nila Ref. 20052



# Confetti

**Designed by** Nutcreatives

Locally produced,  
made from recycled  
plastic from bottle caps.



Less is more!  
Made from recycled plastic  
shavings.

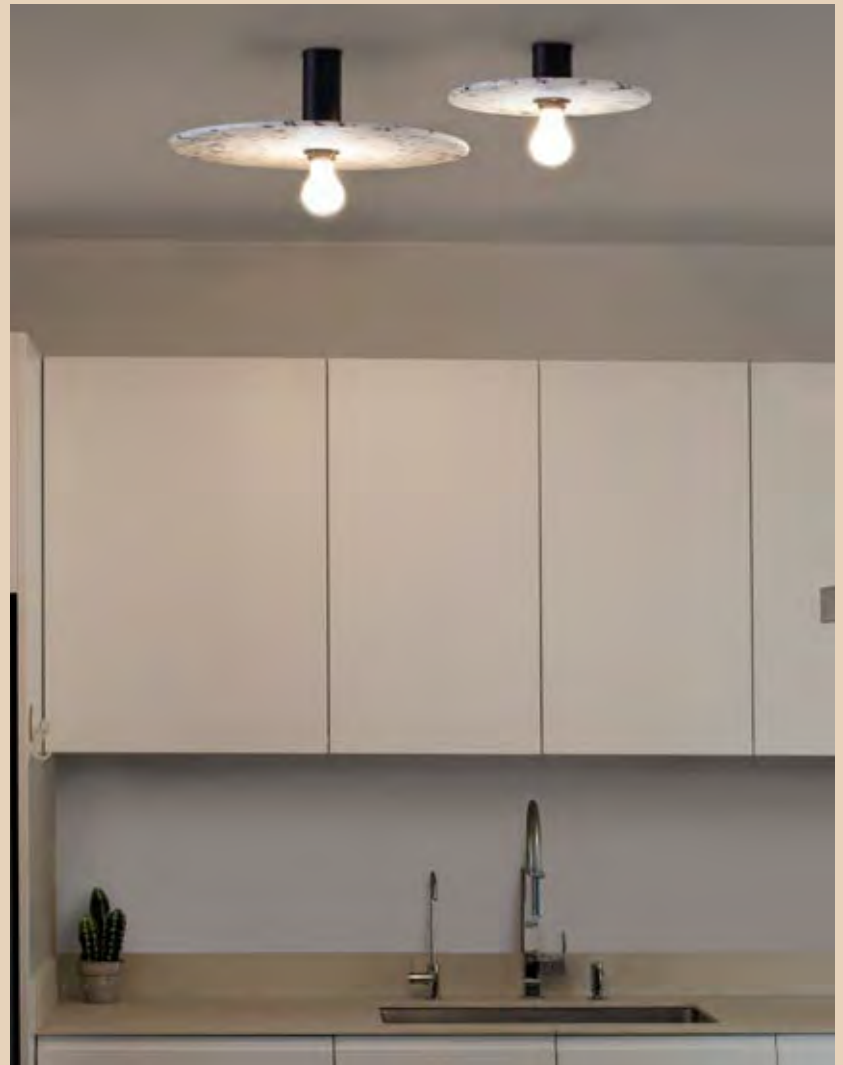

**Confetti 300 H70**  
Nutcreatives



62173-50  Matt Black + White & Black

<b>Material</b>	<b>Body</b> Aluminium
	<b>Shade</b> Recycled PET
<b>Light Source</b>	1 E27 max. 15W
<b>Bulb incl.</b>	No
<b>Class</b>	II
<b>Voltage (V/Hz)</b>	100V-240V/50-60Hz

**Confetti 300 H140**  
Nutcreatives



62174-50  Matt Black + White & Black

<b>Material</b>	<b>Body</b> Aluminium
	<b>Shade</b> Recycled PET
<b>Light Source</b>	1 E27 max. 15W
<b>Bulb incl.</b>	No
<b>Class</b>	II
<b>Voltage (V/Hz)</b>	100V-240V/50-60Hz



**Suspended**  
198

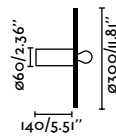
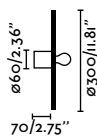

**Confetti 450 H70**  
Nutcreatives



62173-51  Matt Black + White & Black

**Confetti 450 H140**  
Nutcreatives



62174-51  Matt Black + White & Black

<b>Material</b>	<b>Body</b> Aluminium
	<b>Shade</b> Recycled PET
<b>Light Source</b>	1 E27 max. 15W
<b>Bulb incl.</b>	No
<b>Class</b>	II
<b>Voltage (V/Hz)</b>	100V-240V/50-60Hz

<b>Material</b>	<b>Body</b> Aluminium
	<b>Shade</b> Recycled PET
<b>Light Source</b>	1 E27 max. 15W
<b>Bulb incl.</b>	No
<b>Class</b>	II
<b>Voltage (V/Hz)</b>	100V-240V/50-60Hz

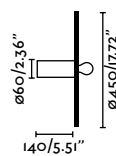
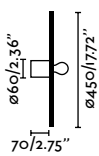





# Inviting

Designed by Bohman And Folenius

Ergonomic  
and human  
centred design.



Inviting Ref. 57301



Colour temperature and  
intensity can be easily adjusted.



reddot award 2019  
winner



GERMAN  
DESIGN  
AWARD  
SPECIAL  
2019

**Inviting**  
Bohman And Folenius



- 57318  Matt White
- 57319  Matt Black
- 57320  Yellow

<b>Material</b>	<b>Body</b> Aluminium
	<b>Diff</b> Transparent PMMA
<b>Power</b>	6W
<b>Lumen Output</b>	410lm
<b>Light Source</b>	SMD LED
<b>Dimmable K</b>	2700 - 4800K
<b>Class</b>	II
<b>CRI</b>	>80
<b>Voltage (V/Hz)</b>	100V-240V/50-60Hz
<b>Cable</b>	1.9 MT

**Inviting**  
Bohman And Folenius



- 57302  Yellow
- 57300  Matt White
- 57301  Matt Black

<b>Material</b>	<b>Body</b> Aluminium
	<b>Diff</b> Transparent PMMA
<b>Power</b>	6W
<b>Lumen Output</b>	410lm
<b>Light Source</b>	SMD LED
<b>Dimmable K</b>	2700 - 4800K
<b>Class</b>	II
<b>CRI</b>	>80
<b>Voltage (V/Hz)</b>	100V-240V/50-60Hz
<b>Cable</b>	1.9 MT

  
**Table&Floor**  
100

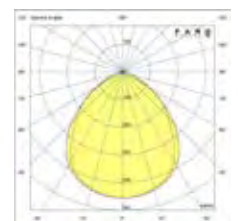
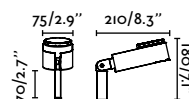
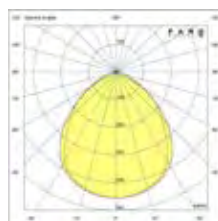
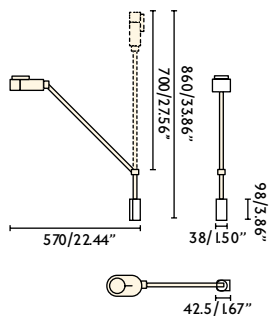

indoor

Surface



# Venice

Designed by Adolfo Abejón



Venice Ref. 64271



Following a traditional and manual process, the shade is produced by casting the ceramic.

Designed and produced locally and handcrafted in Barcelona.



indoor

Surface



**Venice**  
Adolfo Abejón



- 64270 ●● Shiny Black + White
- 64271 ●● Shiny Black + Shiny Black
- 64272 ●● Shiny Black + Pink
- 64273 ●||| Shiny Black + Black & White Gloss
- 64274 ●● Shiny Black + Blue

<b>Material</b>	<b>Body</b> Aluminium
	<b>Shade</b> Ceramic
<b>Light Source</b>	1 E27 max. 15W
<b>Bulb incl.</b>	No
<b>Class</b>	II
<b>Voltage (V/Hz)</b>	100V-240V/50-60Hz



**Suspended Table&Floor**  
192      84

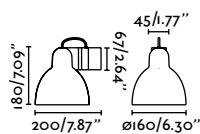







# Costas

Designed by Àlex & Manel Llusca

It brings a  
Mediterranean  
touch to the space  
where you place it.



It is handmade, which reduces  
the impact on the planet.



**Costas 400 H70**  
Àlex & Manel Llusçà



62173-78  Matt Black + Rattan

<b>Material</b>	<b>Body</b> Aluminium
	<b>Shade</b> Rattan
<b>Light Source</b>	1 E27 max. 15W
<b>Bulb incl.</b>	No
<b>Class</b>	II
<b>Voltage (V/Hz)</b>	100V-240V/50-60Hz

**Costas 400 H140**  
Àlex & Manel Llusçà



62174-78  Matt Black + Rattan

<b>Material</b>	<b>Body</b> Aluminium
	<b>Shade</b> Rattan
<b>Light Source</b>	1 E27 max. 15W
<b>Bulb incl.</b>	No
<b>Class</b>	II
<b>Voltage (V/Hz)</b>	100V-240V/50-60Hz



**Suspended**  
228

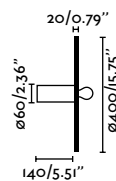
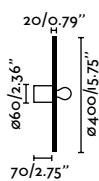

**Costas 600 H70**  
Àlex & Manel Llusçà



62173-69

●● Matt Black + Rattan

<b>Material</b>	<b>Body</b> Aluminium
	<b>Shade</b> Rattan
<b>Light Source</b>	1 E27 max. 15W
<b>Bulb incl.</b>	No
<b>Class</b>	II
<b>Voltage (V/Hz)</b>	100V-240V/50-60Hz

**Costas 600 H140**  
Àlex & Manel Llusçà



62174-69

●● Matt Black + Rattan

<b>Material</b>	<b>Body</b> Aluminium
	<b>Shade</b> Rattan
<b>Light Source</b>	1 E27 max. 15W
<b>Bulb incl.</b>	No
<b>Class</b>	II
<b>Voltage (V/Hz)</b>	100V-240V/50-60Hz

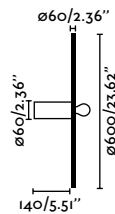
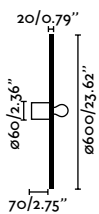

**May**  
Faro Lab

IP44  incl.



- 40095  White
- 40096  Black
- 40097  Blue
- 40098  Coral
- 40099  Green

<b>Material</b>	<b>Body Steel</b>
	Diff Opal White Glass
<b>Power</b>	4W
<b>Lumen Output</b>	300lm
<b>Light Source</b>	COB LED 2700K
<b>Class</b>	II
<b>Voltage (V/Hz)</b>	100V-240V/50-60Hz

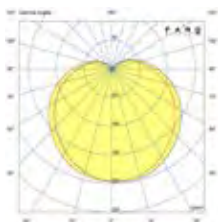
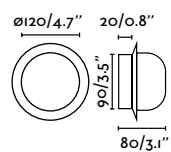

indoor

Surface

# May

Designed by Faro Lab



May Ref. 40095





Thanks to Ekaterina Tkachenko and Alisa Sivyakova | AE design

361

**Moy**  
Nahtrang

IP44 incl.



- 40090  Satin Gold
- 40091  Chrome
- 40092  Bronze
- 40093  Matt Black

<b>Material</b>	<b>Body Steel</b>
	<b>Diff Glass</b>
<b>Power</b>	4W
<b>Lumen Output</b>	300lm
<b>Light Source</b>	SMD LED 3000K
<b>Class</b>	II
<b>CRI</b>	>80
<b>Voltage (V/Hz)</b>	100V-240V/50-60Hz

**Joy**  
Nahtrang

incl.



- 64027  Matt Black
- 64028  Matt White

<b>Material</b>	<b>Body Aluminium</b>
	<b>Diff Glass</b>
<b>Power</b>	3W
<b>Lumen Output</b>	280lm
<b>Light Source</b>	SMD LED 3000K
<b>Class</b>	I
<b>CRI</b>	>80
<b>Voltage (V/Hz)</b>	100V-240V/50-60Hz

**Levita**  
Nahtrang

incl.



- 29690  Shiny Gold
- 29695  Matt Black

<b>Material</b>	<b>Body Steel</b>
	<b>Diff Glass</b>
<b>Power</b>	7W
<b>Lumen Output</b>	570lm
<b>Light Source</b>	SMD LED 2700K
<b>Class</b>	I
<b>CRI</b>	>80
<b>Voltage (V/Hz)</b>	100V-240V/50-60Hz



**Suspended Table&Floor**  
00 124

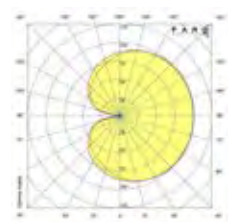
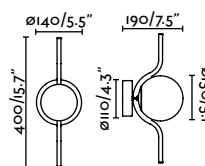
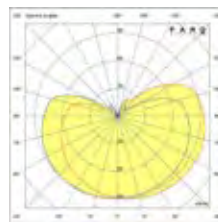
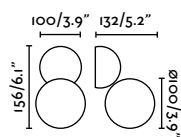
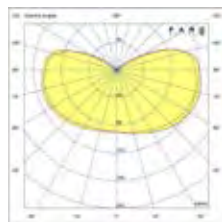
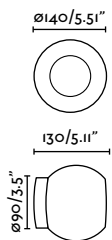



# Moy, Joy & Levita

Designed by Nahtrang



Joy Ref. 64027



Moy Ref. 40093



Levita Ref. 29690

**Magos**  
Faro Lab



- 20330 ● Black
- 20331 ● Maple
- 20332 ● Walnut

<b>Material</b>	<b>Body</b> Aluminium+ABS <b>Diff</b> Opal PC
<b>Power</b>	14W
<b>Lumen Output</b>	600lm
<b>Light Source</b>	SMD LED 2700K
<b>Reader</b>	3W, 2700K, 160lm
<b>Class</b>	II
<b>CRI</b>	>80
<b>Voltage (V/Hz)</b>	100V-240V/50-60Hz

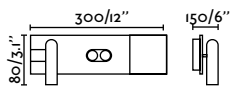

indoor

Surface

# Magos

Designed by Faro Lab



**Whizz extensible**  
Christoph F.W.



- 20167 Matt Black + Satin Gold
- 20168 Matt Black + Satin Gold

<b>Material</b>	<b>Body</b> Steel
	<b>Shade</b> Steel
<b>Light Source</b>	1 E27 max. 15W
<b>Bulb incl.</b>	No
<b>Class</b>	II
<b>Voltage (V/Hz)</b>	100V-240V/50-60Hz
<b>Cable</b>	2 MT

**Whizz**  
Christoph F.W.



- 20165-95 Matt Black + Satin Gold
- 20165-96 Satin Gold + Matt Black

<b>Material</b>	<b>Body</b> Steel
	<b>Shade</b> Steel
<b>Light Source</b>	1 E27 max. 15W
<b>Bulb incl.</b>	No
<b>Class</b>	II
<b>Voltage (V/Hz)</b>	100V-240V/50-60Hz
<b>Cable</b>	3.4 MT

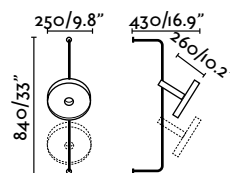
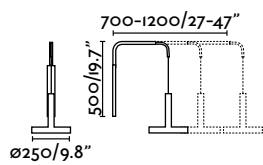

# Whizz

Designed by Christoph F.W.



Whizz extensible Ref. 20167  
Thanks to Jaione Elizalde Estudio



Whizz Ref. 20165-95





**Han**  
Goula / Figuera

  
incl.

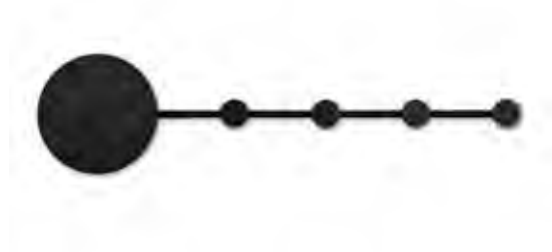

01001-110 ● Matt Black

<b>Material</b>	Body Steel
	Diff Opal PMMA
<b>Power</b>	7W
<b>Lumen Output</b>	500lm
<b>Light Source</b>	SMD LED 2700K
<b>Class</b>	I
<b>CRI</b>	>80
<b>Voltage (V/Hz)</b>	110V/50-60Hz

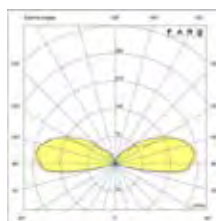
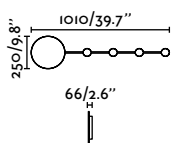

# Han



**Guadalupe**  
Faro Lab



- 20031-80 ●● Black + Beige
- 20031-81 ●● Black + Green

<b>Material</b>	<b>Body</b> Steel
	<b>Shade</b> Steel
<b>Light Source</b>	1 E27 max. 15W
<b>Bulb incl.</b>	No
<b>Class</b>	II
<b>Voltage (V/Hz)</b>	100V-240V/50-60Hz

**Guadalupe reader**  
Faro Lab



- 20032-80 ●● Black + Beige
- 20032-81 ●● Black + Green

<b>Material</b>	<b>Body</b> Steel
	<b>Shade</b> Steel
<b>Light Source</b>	1 E27 max. 15W
<b>Bulb incl.</b>	No
<b>Reader</b>	1W, 3000K, 100lm
<b>Driver incl.</b>	Yes
<b>Class</b>	II
<b>Voltage (V/Hz)</b>	100V-240V/50-60Hz



Table&Floor  
122

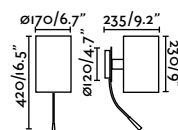
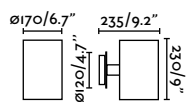

# Guadalupe

Designed by Faro Lab

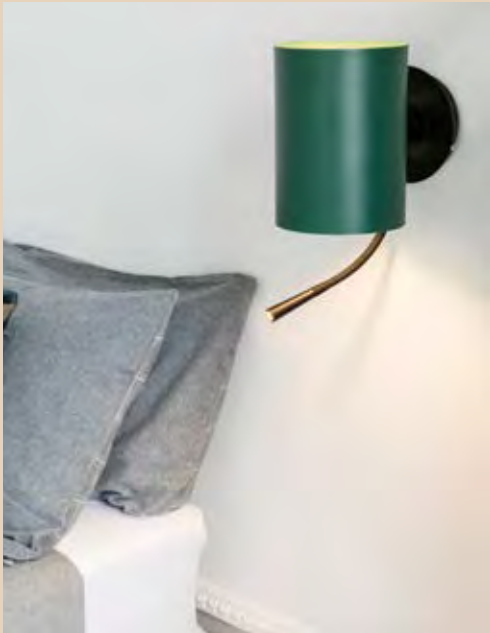

Guadalupe reader Ref. 20032-81

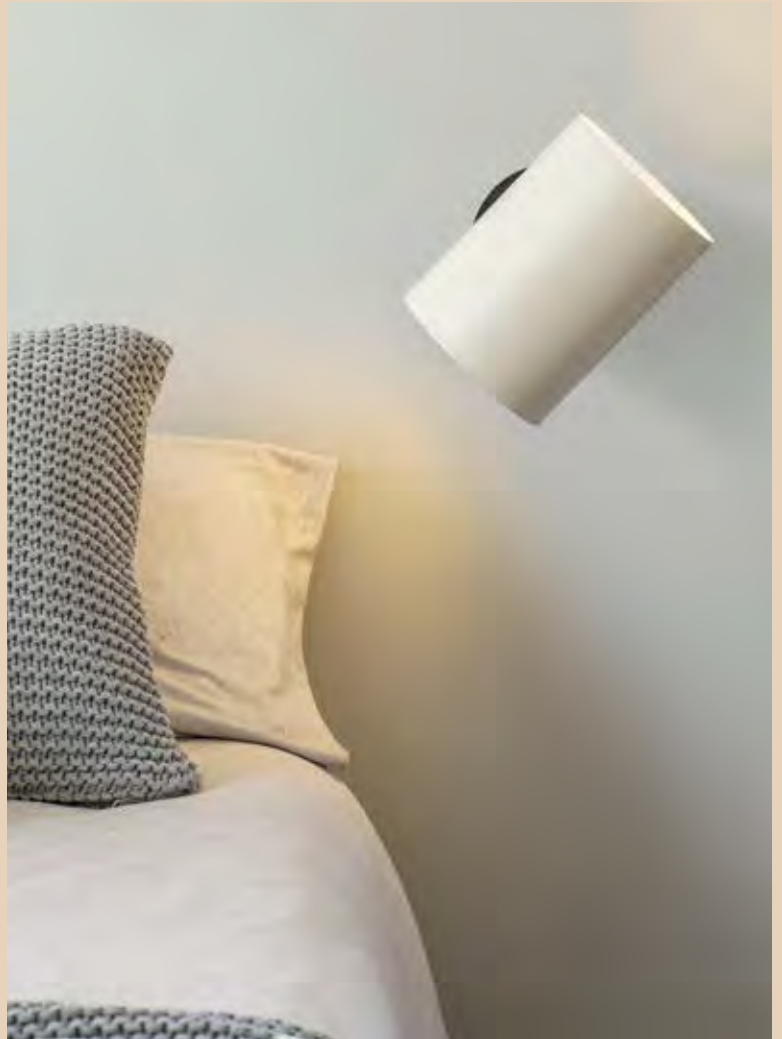

Guadalupe Ref. 20031-80

**Niko Glass right**  
Nahtrang



01009A ● ● Matt White + Wood

<b>Material</b>	<b>Body</b> Aluminium
	<b>Diff</b> Opal Glass
<b>Power</b>	7W
<b>Lumen Output</b>	500lm
<b>Light Source</b>	SMD LED 3000K
<b>Dimmable W</b>	1w 80lm / 4w 250lm / 7w 500lm
<b>Class</b>	II
<b>CRI</b>	>80
<b>Voltage (V/Hz)</b>	100V-240V/50-60Hz

**Niko PC right**  
Nahtrang



01027A ● ● Matt White + Wood

<b>Material</b>	<b>Body</b> Aluminium+Wood
	<b>Diff</b> Opal PC
<b>Power</b>	7W
<b>Lumen Output</b>	500lm
<b>Light Source</b>	SMD LED 3000K
<b>Dimmable W</b>	1w 80lm / 4w 250lm / 7w 500lm
<b>Class</b>	II
<b>CRI</b>	>80
<b>Voltage (V/Hz)</b>	100V-240V/50-60Hz



Table  
104

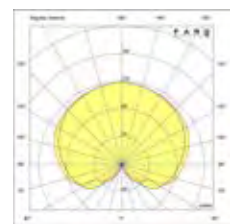
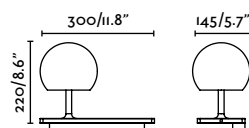
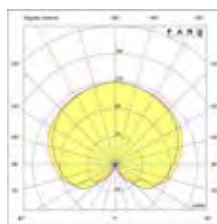
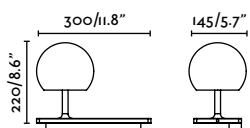



# Niko

Designed by Nahtrang

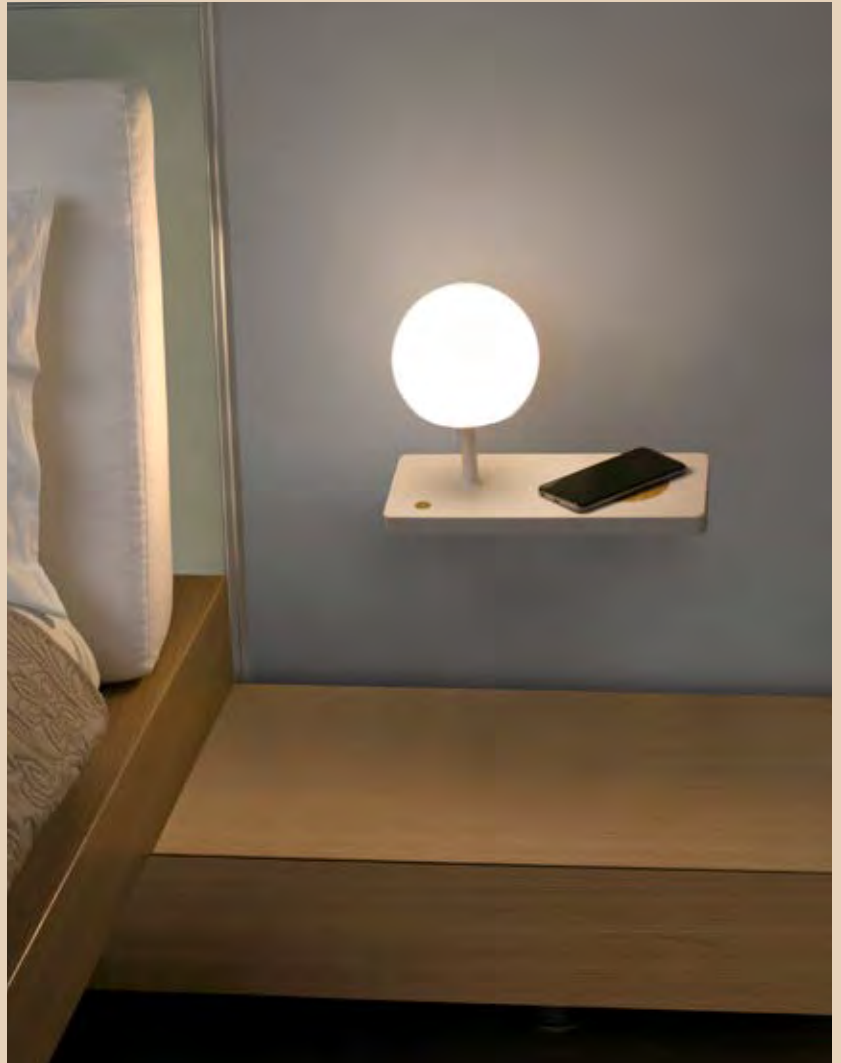

Niko PC right Ref. 01027A



Touch it to adjust the intensity of the light and charge your phone without a cable, in its wooden base.

**Niko Glass left**  
Nahtrang



01014A ● ● Matt White + Wood

<b>Material</b>	<b>Body</b> Aluminium+Wood
	<b>Diff</b> Opal Glass
<b>Power</b>	7W
<b>Lumen Output</b>	500lm
<b>Light Source</b>	SMD LED 3000K
<b>Dimmable W</b>	1w 80lm / 4w 250lm / 7w 500lm
<b>Class</b>	II
<b>CRI</b>	>80
<b>Voltage (V/Hz)</b>	100V-240V/50-60Hz

**Niko PC left**  
Nahtrang



01026A ● ● Matt White + Wood

<b>Material</b>	<b>Body</b> Aluminium+Wood
	<b>Diff</b> Opal PC
<b>Power</b>	7W
<b>Lumen Output</b>	500lm
<b>Light Source</b>	SMD LED 3000K
<b>Dimmable W</b>	1w 80lm / 4w 250lm / 7w 500lm
<b>Class</b>	II
<b>CRI</b>	>80
<b>Voltage (V/Hz)</b>	100V-240V/50-60Hz



Table  
104

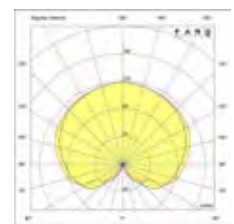
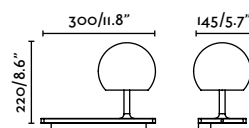
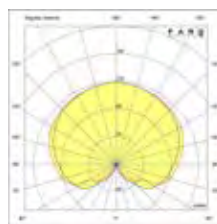
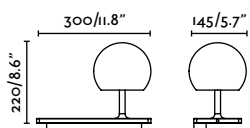

indoor

Surface



Niko Glass left Ref. 01014A

375

**Stood**  
Lucid Product Design



29844

●● Matt Black + Cherry

<b>Material</b>	<b>Body</b> Steel
	<b>Shade</b> Wood
<b>Light Source</b>	1 E27 max. 15W
<b>Bulb incl.</b>	No
<b>Class</b>	II
<b>Voltage (V/Hz)</b>	100V-240V/50-60Hz



**Suspended** 204  
**Table&Floor** 128

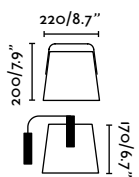



indoor

Surface

# Stood

Designed by Lucid Product Design





**Loop**  
Estudi Ribaudí



- 29395-110   Matt Black + Ash Tree
- 29565-110   Matt Black + Cherry

<b>Material</b>	<b>Body</b> Steel
	<b>Shade</b> Wood
<b>Power</b>	6W
<b>Lumen Output</b>	500lm
<b>Light Source</b>	SMD LED 2700K
<b>Class</b>	II
<b>CRI</b>	>80
<b>Voltage (V/Hz)</b>	110V/50-60Hz

**Loop Articulated**  
Estudi Ribaudí

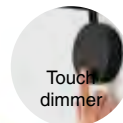

- 29566-110   Matt Black + Cherry
- 29396-110  Matt Black

<b>Material</b>	<b>Body</b> Steel
	<b>Shade</b> Wood
<b>Power</b>	6W
<b>Lumen Output</b>	500lm
<b>Light Source</b>	SMD LED 2700K
<b>Class</b>	II
<b>CRI</b>	>80
<b>Voltage (V/Hz)</b>	110V/50-60Hz

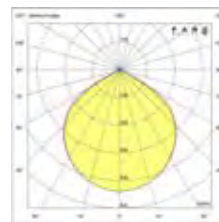
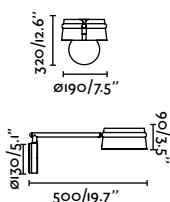
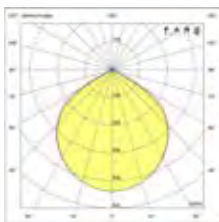
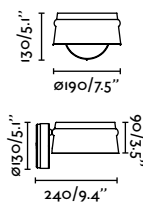
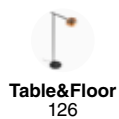

# Loop

Designed by Estudi Ribaudí

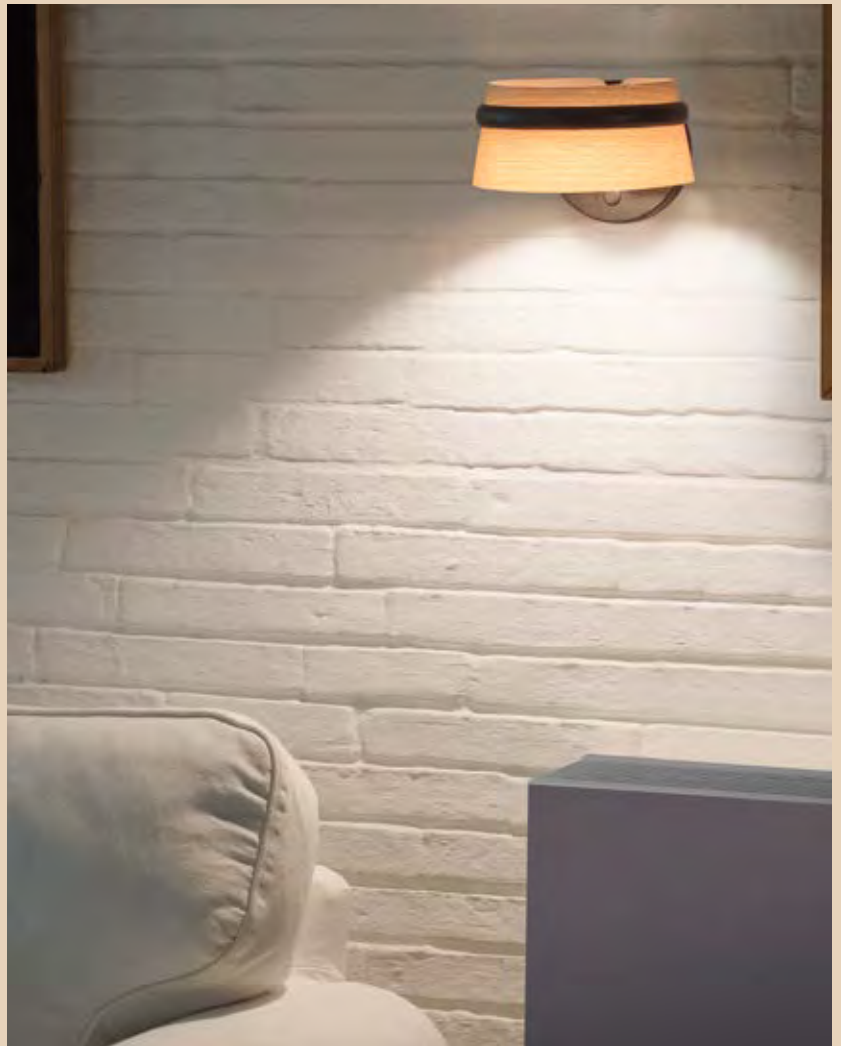

Loop Ref. 29395-110



Natural laminated wood of American origin.



Loop Articulated Ref. 29566-110

**Samba**  
Faro Lab



- 64306-35  White + Beige
- 64306-36  White + Yellow
- 64306-37  White + Green
- 64307-35  Black + Beige
- 64307-36  Black + Yellow
- 64307-37  Black + Green

<b>Material</b>	<b>Body</b> Steel
	<b>Shade</b> Textile
<b>Light Source</b>	1 E27 max. 15W
<b>Bulb incl.</b>	No
<b>Class</b>	I
<b>Voltage (V/Hz)</b>	100V-240V/50-60Hz

**Samba reader**  
Faro Lab



- 64308-35  Matt White + Beige
- 64308-36  Matt White + Yellow
- 64308-37  Matt White + Green
- 64309-35  Matt Black + Beige
- 64309-36  Matt Black + Yellow
- 64309-37  Matt Black + Green

<b>Material</b>	<b>Body</b> Steel
	<b>Shade</b> Textile
<b>Light Source</b>	1 E27 max. 15W
<b>Bulb incl.</b>	No
<b>Reader</b>	3W, 3000K, 280lm
<b>Driver incl.</b>	Yes
<b>Class</b>	I
<b>Voltage (V/Hz)</b>	100V-240V/50-60Hz



**Suspended Table&Floor**  
238      138

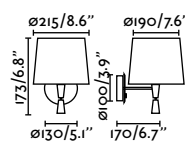
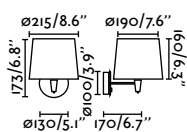

\*Structures and shades also sold separately 598-601

indoor

Surface

# Samba

Designed by Faro Lab



Samba reader Ref. 64308-35

**Savoy**  
Isaac Piñeiro



- 20300-92  Matt White + White
- 20301-93  Matt Black + Black
- 20301-94   Matt Black + Green

<b>Material</b>	<b>Body</b> Steel
	<b>Diff</b> Steel
	<b>Shade</b> Textile
<b>Light Source</b>	1 E27 max. 15W
<b>Bulb incl.</b>	No
<b>Class</b>	II
<b>Voltage (V/Hz)</b>	100V-240V/50-60Hz

**Montreal**  
Nahrang



- 24030-01  Matt White + White
- 24030-02  Matt White + Beige
- 24031-01  Chrome + White
- 24031-02   Chrome + Beige
- 24031-03   Chrome + Black

<b>Material</b>	<b>Body</b> Steel
	<b>Shade</b> Textile
<b>Light Source</b>	1 E27 max. 15W
<b>Bulb incl.</b>	No
<b>Class</b>	II
<b>Voltage (V/Hz)</b>	100V-240V/50-60Hz



**Suspended Table&Floor**  
242 144



**Table&Floor**  
142

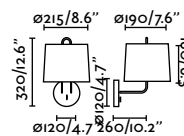
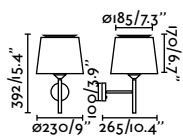

\*Structures and shades also sold separately 598-601



# Savoy & Montreal



Montreal reader Ref. 24032-01



Montreal Ref. 24031-03

**Conga**  
Faro Lab



- 64306-01  Matt White + White
- 64306-02  Matt White + Beige
- 64307-03  Matt Black + Black

<b>Material</b>	<b>Body</b> Steel
	<b>Shade</b> Textile
<b>Light Source</b>	1 E27 max. 15W
<b>Bulb incl.</b>	No
<b>Class</b>	I
<b>Voltage (V/Hz)</b>	100V-240V/50-60Hz

**Conga reader**  
Faro Lab

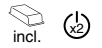

- 64308-01  Matt White + White
- 64308-02  Matt White + Beige
- 64309-03  Matt Black + Black

<b>Material</b>	<b>Body</b> Steel
	<b>Shade</b> Textile
<b>Light Source</b>	1 E27 max. 15W
<b>Bulb incl.</b>	No
<b>Reader</b>	3W, 3000K, 280lm
<b>Driver incl.</b>	Yes
<b>Class</b>	I
<b>Voltage (V/Hz)</b>	100V-240V/50-60Hz



**Suspended Table&Floor**  
240      140

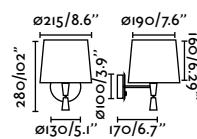
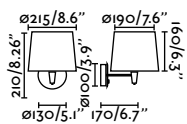

\*Structures and shades also sold separately 598-601

indoor

Surface

# Conga

Designed by Faro Lab



**Sumba**  
Faro Lab

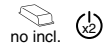

64307-71 Matt Black + Rattan

<b>Material</b>	<b>Body</b> Steel
	<b>Shade</b> Rattan
<b>Light Source</b>	1 E27 max. 15W
<b>Bulb incl.</b>	No
<b>Class</b>	I
<b>Voltage (V/Hz)</b>	100V-240V/50-60Hz

**Sumba reader**  
Faro Lab

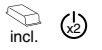

64309-71 Matt Black + Rattan

<b>Material</b>	<b>Body</b> Steel
	<b>Shade</b> Rattan
<b>Light Source</b>	1 E27 max. 15W
<b>Bulb incl.</b>	No
<b>Reader</b>	3W, 3000K, 280lm
<b>Driver incl.</b>	Yes
<b>Class</b>	I
<b>Voltage (V/Hz)</b>	100V-240V/50-60Hz



**Suspended**  
230



**Table**  
110

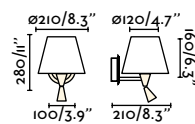
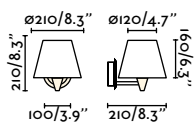

indoor

Surface

# Sumba

Designed by Faro Lab





**Mambo**  
Faro Lab



64307-47  Matt Black + Rattan

<b>Material</b>	<b>Body</b> Steel
	<b>Shade</b> Rattan
<b>Light Source</b>	1 E27 max. 15W
<b>Bulb incl.</b>	No
<b>Class</b>	I
<b>Voltage (V/Hz)</b>	100V-240V/50-60Hz

**Mambo reader**  
Faro Lab

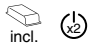

64309-47  Matt Black + Rattan

<b>Material</b>	<b>Body</b> Steel
	<b>Shade</b> Rattan
<b>Light Source</b>	1 E27 max. 15W
<b>Bulb incl.</b>	No
<b>Reader</b>	3W, 3000K, 280lm
<b>Driver incl.</b>	Yes
<b>Class</b>	I
<b>Voltage (V/Hz)</b>	100V-240V/50-60Hz



**Suspended Table&Floor**  
281 136

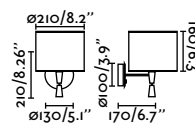
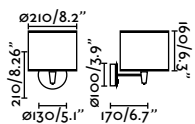

\*Structures and shades also sold separately 598-601

indoor

Surface

# Mambo

Designed by Faro Lab



**Artis**  
Àlex & Manel Lluscà



- 68490-01 Old Bronze + White
- 68490-02 Old Bronze + Beige
- 68490-03 Old Bronze + Black

<b>Material</b>	<b>Body Steel</b>
	<b>Shade Textile</b>
<b>Light Source</b>	1 E27 max. 15W
<b>Bulb incl.</b>	No
<b>Class</b>	I
<b>Voltage (V/Hz)</b>	100V-240V/50-60Hz

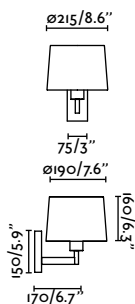

**Artis reader**  
Àlex & Manel Lluscà



- 68492-01 Old Bronze + White
- 68492-02 Old Bronze + Beige
- 68492-03 Old Bronze + Black
- 68493-01 Chrome + White
- 68493-02 Chrome + Beige
- 68493-03 Chrome + Black

<b>Material</b>	<b>Body Steel</b>
	<b>Shade Textile</b>
<b>Light Source</b>	1 E27 max. 15W
<b>Bulb incl.</b>	No
<b>Reader</b>	1W, 3000K, 140lm
<b>Driver incl.</b>	Yes
<b>Class</b>	I
<b>Voltage (V/Hz)</b>	100V-240V/50-60Hz

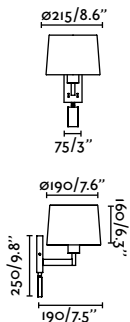

**Artis articulated**  
Àlex & Manel Lluscà



- 68494-01 Bronze + White
- 68494-02 Bronze + Beige
- 68494-03 Bronze + Black
- 68495-01 Chrome + White
- 68495-02 Chrome + Beige
- 68495-03 Chrome + Black

<b>Material</b>	<b>Body Steel</b>
	<b>Shade Textile</b>
<b>Light Source</b>	1 E27 max. 15W
<b>Bulb incl.</b>	No
<b>Class</b>	I
<b>Voltage (V/Hz)</b>	100V-240V/50-60Hz

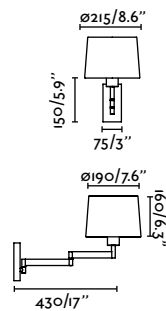

\*Structures and shades also sold separately 598-601

indoor

Surface

# Artis

Designed by Àlex & Manel Llusçà



**Eterna**  
Lucid Product Design



- 24005-10 Chrome + White
- 24005-11 Chrome + Beige
- 24005-12 Chrome + Black

<b>Material</b>	<b>Body Steel</b>
	<b>Shade Textile</b>
<b>Light Source</b>	1 E27 max. 15W
<b>Bulb incl.</b>	No
<b>Class</b>	II
<b>Voltage (V/Hz)</b>	100V-240V/50-60Hz

**Eterna reader right**  
Lucid Product Design



- 24006-10-110 Chrome + White
- 24006-11-110 Chrome + Beige
- 24006-12-110 Chrome + Black

<b>Material</b>	<b>Body Steel</b>
	<b>Shade Textile</b>
<b>Light Source</b>	1 E27 max. 15W
<b>Bulb incl.</b>	No
<b>Reader</b>	1W, 2700K, 90lm
<b>Driver incl.</b>	Yes
<b>Class</b>	II
<b>Voltage (V/Hz)</b>	110V/50-60Hz

**Eterna reader left**  
Lucid Product Design



- 24007-10-110 Chrome + White
- 24007-11-110 Chrome + Beige
- 24007-12-110 Chrome + Black

<b>Material</b>	<b>Body Steel</b>
	<b>Shade Textile</b>
<b>Light Source</b>	1 E27 max. 15W
<b>Bulb incl.</b>	No
<b>Reader</b>	1W, 2700K, 90lm
<b>Driver incl.</b>	Yes
<b>Class</b>	II
<b>Voltage (V/Hz)</b>	110V/50-60Hz

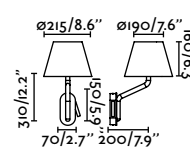
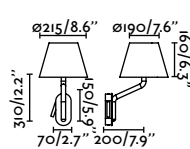
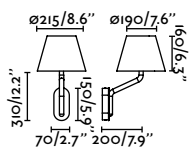

\*Structures and shades also sold separately 598-601



Table  
110



indoor

Surface

# Eterna

Designed by Lucid Product Design



**Rem**  
Àlex & Manel Llusçà



- 29680-19  Matt Nickel + White
- 29680-20  Matt Nickel + Beige
- 29680-21  Matt Nickel + Black
- 29681-19  Old Gold + White
- 29681-20  Old Gold + Beige
- 29681-21  Old Gold + Black

<b>Material</b>	<b>Body</b> Steel
	<b>Shade</b> Textile
<b>Light Source</b>	1 E27 max. 15W
<b>Bulb incl.</b>	No
<b>Class</b>	I
<b>Voltage (V/Hz)</b>	100V-240V/50-60Hz

**Rem reader**  
Àlex & Manel Llusçà

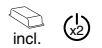

- 29683-19  Old Gold + White
- 29683-20  Old Gold + Beige
- 29683-21  Old Gold + Black

<b>Material</b>	<b>Body</b> Steel
	<b>Shade</b> Textile
<b>Light Source</b>	1 E27 max. 15W
<b>Bulb incl.</b>	No
<b>Reader</b>	4W, 3000K, 120lm
<b>Driver incl.</b>	Yes
<b>Class</b>	I
<b>Voltage (V/Hz)</b>	100V-240V/50-60Hz



**Table&Floor**  
146

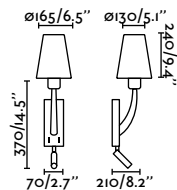
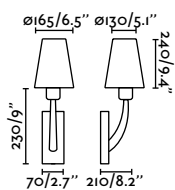

\*Structures and shades also sold separately 598-601

indoor

Surface

# Rem

Designed by Àlex & Manel Lluscà



**Frame**  
Nahrang



- 20170-01  Matt Nickel + White
- 20170-02  Matt Nickel + Beige
- 20170-03  Matt Nickel + Black
- 20171-01  Old Gold + White
- 20171-02  Old Gold + Beige
- 20171-03  Old Gold + Black

<b>Material</b>	<b>Body</b> Steel
	<b>Shade</b> Textile
<b>Light Source</b>	1 E27 max. 15W
<b>Bulb incl.</b>	No
<b>Class</b>	I
<b>Voltage (V/Hz)</b>	100V-240V/50-60Hz

**Frame reader**  
Nahrang

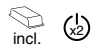

- 20172-01  Matt Nickel + White
- 20172-02  Matt Nickel + Beige
- 20172-03  Matt Nickel + Black
- 20173-01  Old Gold + White
- 20173-02  Old Gold + Beige
- 20173-03  Old Gold + Black

<b>Material</b>	<b>Body</b> Steel
	<b>Shade</b> Textile
<b>Light Source</b>	1 E27 max. 15W
<b>Bulb incl.</b>	No
<b>Reader</b>	3W, 3000K, 100lm
<b>Driver incl.</b>	Yes
<b>Class</b>	I
<b>Voltage (V/Hz)</b>	100V-240V/50-60Hz

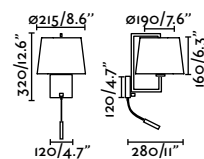
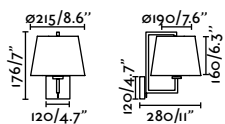

\*Structures and shades also sold separately 598-601



indoor

Surface

# Frame

Designed by Nahtrang

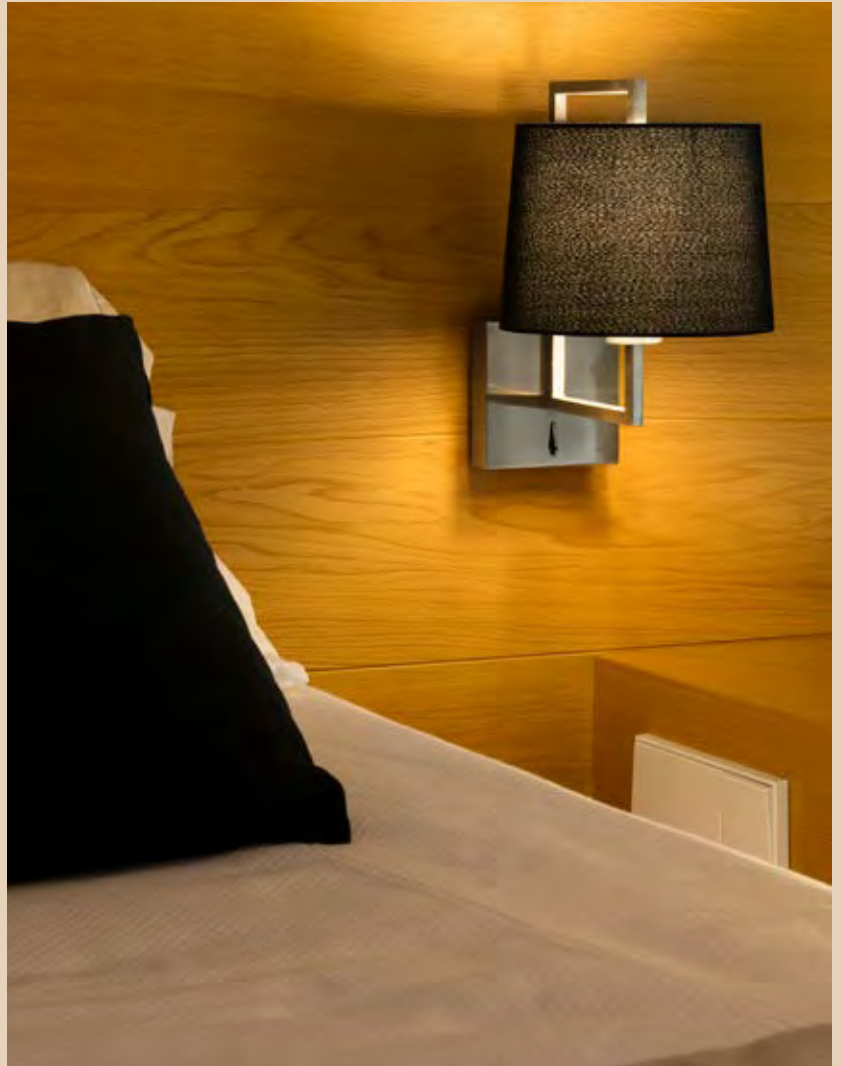

Frame Ref. 20170-03



Frame reader Ref. 20173-02



**Lupe**  
Jordi Busquets



20031-88 ●● Black + Beige

<b>Material</b>	<b>Body</b> Steel
	<b>Shade</b> Textile
<b>Light Source</b>	1 E27 max. 15W
<b>Bulb incl.</b>	No
<b>Class</b>	I
<b>Voltage (V/Hz)</b>	100V-240V/50-60Hz

**Lupe reader**  
Jordi Busquets



20032-88 ●● Black + Beige  
29996 ●● Chrome + White

<b>Material</b>	<b>Body</b> Steel
	<b>Shade</b> Steel
<b>Light Source</b>	1 E27 max. 15W
<b>Bulb incl.</b>	No
<b>Reader</b>	1W, 3000K, 100lm
<b>Driver incl.</b>	Yes
<b>Class</b>	I
<b>Voltage (V/Hz)</b>	100V-240V/50-60Hz



**Table&Floor**  
156

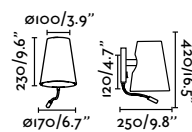
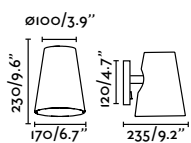

indoor

Surface

# Lupe

Designed by Jordi Busquets



**Fold**  
Nutcreatives



- 64302  Matt White + White
- 64303  Matt Black + Black

<b>Material</b>	<b>Body</b> Steel
	<b>Shade</b> Textile
<b>Light Source</b>	1 E27 max. 15W
<b>Bulb incl.</b>	No
<b>Class</b>	I
<b>Voltage (V/Hz)</b>	100V-240V/50-60Hz

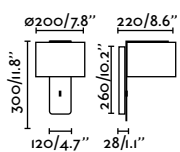

**Fold reader**  
Nutcreatives



- 64304  Matt White + White
- 64305  Matt Black + Black

<b>Material</b>	<b>Body</b> Steel
	<b>Shade</b> Textile
<b>Light Source</b>	1 E27 max. 15W
<b>Bulb incl.</b>	No
<b>Reader</b>	3W, 3000K, 200lm
<b>Driver incl.</b>	Yes
<b>Class</b>	I
<b>Voltage (V/Hz)</b>	100V-240V/50-60Hz

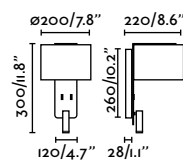

indoor

Surface

# Fold

Designed by Nutcreatives



Fold Ref. 64303



Fold reader Ref. 64304

**Hotel**  
Àlex & Manel Llusca



29940 Chrome + White

<b>Material</b>	<b>Body</b> Steel
	<b>Shade</b> Textile
<b>Light Source</b>	1 E27 max. 15W
<b>Bulb incl.</b>	No
<b>Class</b>	I
<b>Voltage (V/Hz)</b>	100V-240V/50-60Hz

**Hotel reader**  
Àlex & Manel Llusca



29946 Chrome + Black

<b>Material</b>	<b>Body</b> Steel
	<b>Shade</b> Textile
<b>Light Source</b>	1 E27 max. 15W
<b>Bulb incl.</b>	No
<b>Reader</b>	1W, 3500K, 80lm
<b>Driver incl.</b>	Yes
<b>Class</b>	I
<b>Voltage (V/Hz)</b>	100V-240V/50-60Hz



**Suspended Table&Floor**  
246 162

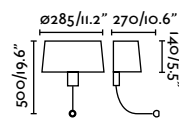
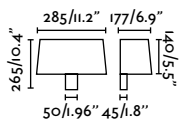



indoor

Surface

# Hotel

Designed by Àlex & Manel Llusçà



Hotel Ref. 29940

403

**Room**  
Àlex & Manel Llusçà



- 29974  Satin Nickel + White
- 29975  Satin Nickel + Black

<b>Material</b>	<b>Body</b> Steel
	<b>Shade</b> Textile
<b>Light Source</b>	1 E27 max. 15W
<b>Bulb incl.</b>	No
<b>Class</b>	I
<b>Voltage (V/Hz)</b>	100V-240V/50-60Hz

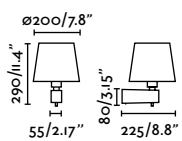

**Room reader**  
Àlex & Manel Llusçà

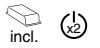

- 29976  Satin Nickel + White

<b>Material</b>	<b>Body</b> Steel
	<b>Shade</b> Textile
<b>Light Source</b>	1 E27 max. 15W
<b>Bulb incl.</b>	No
<b>Reader</b>	3W, 3000K, 160lm
<b>Driver incl.</b>	Yes
<b>Class</b>	II
<b>Voltage (V/Hz)</b>	100V-240V/50-60Hz

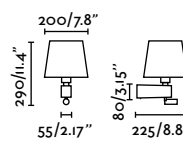

indoor

Surface

# Room

Designed by Àlex & Manel Llusçà



Room Ref. 29975



**Vesper**  
Nahtrang



**Vesper reader**  
Nahtrang



- 29980  Matt White + Beige
- 29981  Brown + Beige

- 29982  Matt White + Beige
- 29983  Brown + Beige

<b>Material</b>	<b>Body</b> Steel
	<b>Shade</b> Textile
<b>Light Source</b>	1 E14 max. 8W
<b>Bulb incl.</b>	No
<b>Class</b>	I
<b>Voltage (V/Hz)</b>	100V-240V/50-60Hz

<b>Material</b>	<b>Body</b> Steel
	<b>Shade</b> Textile
<b>Light Source</b>	1 E14 max. 8W
<b>Bulb incl.</b>	No
<b>Reader</b>	1W, 3000K, 120lm
<b>Driver incl.</b>	Yes
<b>Class</b>	I
<b>Voltage (V/Hz)</b>	100V-240V/50-60Hz



**Suspended Table&Floor**  
244 152

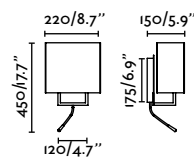
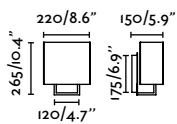

indoor

Surface

# Vesper

Designed by Nahtrang

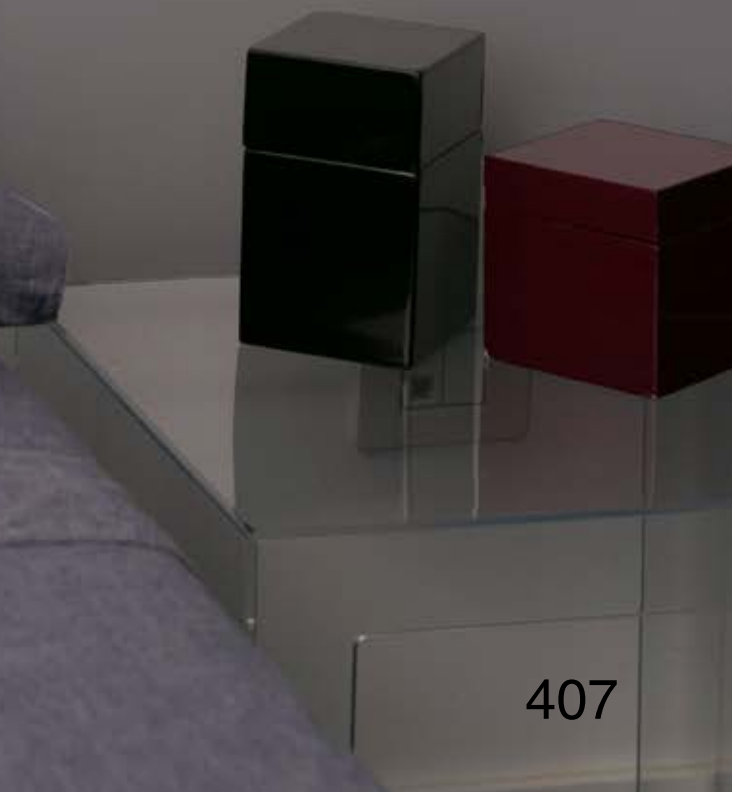

Vesper reader Ref. 29982

407



**Berni**  
Nahtrng



- 29326  Matt White + White
- 29328  Satin Nickel + White

<b>Material</b>	<b>Body</b> Steel
	<b>Shade</b> Textile
<b>Light Source</b>	1 E27 max. 15W
<b>Bulb incl.</b>	No
<b>Class</b>	I
<b>Voltage (V/Hz)</b>	100V-240V/50-60Hz

**Berni reader**  
Nahtrng



- 29329  Matt White + White
- 29330  Matt Black + Black
- 29331  Satin Nickel + White

<b>Material</b>	<b>Body</b> Steel
	<b>Shade</b> Textile
<b>Light Source</b>	1 E27 max. 15W
<b>Bulb incl.</b>	No
<b>Reader</b>	3W, 3000K, 200lm
<b>Driver incl.</b>	Yes
<b>Class</b>	I
<b>Voltage (V/Hz)</b>	100V-240V/50-60Hz



**Table&Floor**  
160

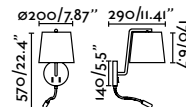
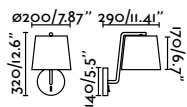

indoor

Surface

# Berni

Designed by Nahrang



Berni reader Ref. 29330  
Thanks to Elena Castells Poch

**Sweet reader**  
Estudi Ribaudí



- 29950  Matt White + White
- 29951  Matt Black + Black

<b>Material</b>	<b>Body Steel</b>
	<b>Diff White Textile</b>
	<b>Shade Textile</b>
<b>Light Source</b>	1 E27 max. 15W
<b>Bulb incl.</b>	No
<b>Reader</b>	1W, 3000K, 200lm
<b>Driver incl.</b>	Yes
<b>Class</b>	I
<b>Voltage (V/Hz)</b>	100V-240V/50-60Hz

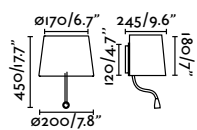

indoor

Surface

# Sweet

Designed by Estudi Ribaudí



**Handy**  
Jordi Blasi



28413 ●● Matt White + White

**Handy right**  
Jordi Blasi



28414 ●● Matt White + White

**Handy Left**  
Jordi Blasi



28415 ●● Matt White + White

<b>Material</b>	<b>Body Steel</b>
	<b>Shade Textile</b>
<b>Light Source</b>	1 E27 max. 15W
<b>Bulb incl.</b>	No
<b>Class</b>	I
<b>Voltage (V/Hz)</b>	100V-240V/50-60Hz

<b>Material</b>	<b>Body Steel</b>
	<b>Shade Textile</b>
<b>Light Source</b>	1 E27 max. 15W
<b>Bulb incl.</b>	No
<b>Reader</b>	3W, 3000K, 40lm
<b>Driver incl.</b>	Yes
<b>Class</b>	I
<b>Voltage (V/Hz)</b>	100V-240V/50-60Hz

<b>Material</b>	<b>Body Steel</b>
	<b>Shade Textile</b>
<b>Light Source</b>	1 E27 max. 15W
<b>Bulb incl.</b>	No
<b>Reader</b>	3W, 3000K, 40lm
<b>Driver incl.</b>	Yes
<b>Class</b>	I
<b>Voltage (V/Hz)</b>	100V-240V/50-60Hz

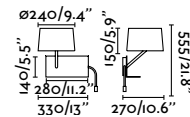
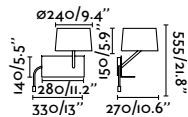
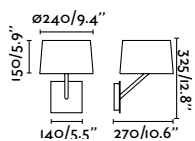



indoor

Surface

# Handy

Designed by Jordi Blasi



Handy Ref. 28413



## Tira



- 64322  Matt White + White  
 64323  Matt Black + Black

<b>Material</b>	<b>Body</b> Steel+Aluminium+Silicone
	<b>Shade</b> Textile
<b>Light Source</b>	1 E27 max. 15W
<b>Bulb incl.</b>	No
<b>Reader</b>	3W, 3000K, 280lm
<b>Driver incl.</b>	Yes
<b>Class</b>	I
<b>Voltage (V/Hz)</b>	100V-240V/50-60Hz

## Sahara



- 62705  Chrome + Beige  
 62706  Chrome + White

<b>Material</b>	<b>Body</b> Steel
	<b>Shade</b> Textile
<b>Light Source</b>	1 E27 max. 15W
<b>Bulb incl.</b>	No
<b>Class</b>	I
<b>Voltage (V/Hz)</b>	100V-240V/50-60Hz

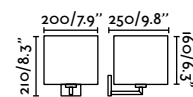

## Roda



- 62988  Satin Nickel + White

<b>Material</b>	<b>Body</b> Steel
	<b>Shade</b> Textile
<b>Light Source</b>	1 E27 max. 15W
<b>Bulb incl.</b>	No
<b>Class</b>	I
<b>Voltage (V/Hz)</b>	100V-240V/50-60Hz

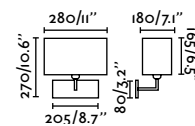

indoor

Surface

# Sahara

MAATDIENST OM DE VEERTIEN DAGEN  
VAN ROTTERDAM NAAR JAVA  
VIA SOUTHAMPTON EN MARSAILLE



## Moma



68504

Chrome + White

<b>Material</b>	<b>Body</b> Steel
	<b>Shade</b> Textile
<b>Light Source</b>	1 E27 max. 15W
<b>Bulb incl.</b>	No
<b>Class</b>	I
<b>Voltage (V/Hz)</b>	100V-240V/50-60Hz

## Moma reader



68507

Chrome + Black

<b>Material</b>	<b>Body</b> Steel
	<b>Shade</b> Textile
<b>Light Source</b>	1 E27 max. 15W
<b>Bulb incl.</b>	No
<b>Reader</b>	1W, 6000K, 80lm
<b>Driver incl.</b>	Yes
<b>Class</b>	I
<b>Voltage (V/Hz)</b>	100V-240V/50-60Hz



Table&Floor  
170

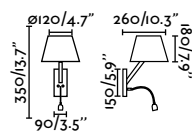
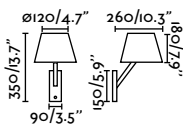



indoor

Surface

# Moma





## Stan switch

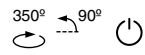

- 43767  Matt White
- 43768  Matt Black

<b>Material</b>	<b>Body</b> Aluminium+ABS
<b>Light Source</b>	1 GU10 max. 5W
<b>Bulb incl.</b>	No
<b>Class</b>	I
<b>Voltage (V/Hz)</b>	100V-240V/50-60Hz

-   
**Suspended**  
266
-   
**Track**  
566
-   
**Ceiling**  
306
-   
**Recessed**  
550
-   
**Surface**  
480

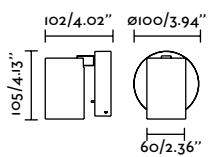

indoor

Surface

# Stan switch

NEW



**Duas**  
Faro Lab

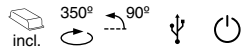

- 68467  Matt White + Shiny White
- 68468  Matt Black + Shiny Black

<b>Material</b>	Body Steel
<b>Power</b>	3W
<b>Lumen Output</b>	240 lm
<b>Light Source</b>	COB LED 2700K
<b>Class</b>	II
<b>CRI</b>	>=80
<b>Voltage (V/Hz)</b>	100V-240V/50-60Hz
<b>Beam angle</b>	45°

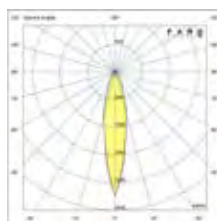
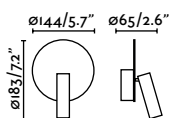

indoor

Surface

# Duas

Designed by Faro Lab



Duas Ref. 68468



**Aurea**  
Estudi Ribaudí

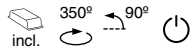

62115 ● Matt White

<b>Material</b>	Body Steel Diff Opal PC
<b>Power</b>	8W
<b>Lumen Output</b>	300lm
<b>Light Source</b>	SMD LED 2700K
<b>Class</b>	I
<b>CRI</b>	>80
<b>Voltage (V/Hz)</b>	100V-240V/50-60Hz

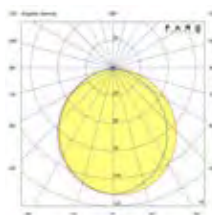
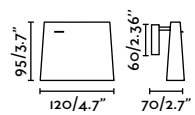

**Le Petit**  
Àlex & Manel Llusçà



62161 ● Matt White  
62162 ● Matt Black  
62163 ● Satin Gold  
62164 ● Bronze

<b>Material</b>	Body Steel
<b>Power</b>	4W
<b>Lumen Output</b>	130lm
<b>Light Source</b>	SMD LED 3000K
<b>Class</b>	II
<b>CRI</b>	>80
<b>Voltage (V/Hz)</b>	100V-240V/50-60Hz

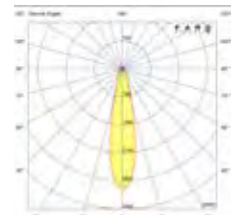
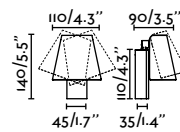



indoor

Surface

# Le Petit

Designed by Àlex & Manel Llusca



Le Petit Ref. 62163  
Thanks to MIKMAX

## Rob



- 68497  Bronze
- 68499  Satin Nickel
- 68508  White
- 68509  Black

<b>Material</b>	<b>Body</b> Steel+Aluminium
<b>Power</b>	3W
<b>Lumen Output</b>	160lm
<b>Light Source</b>	HIGH POWER LED 3000K
<b>Reader</b>	3W, 3000K, 160lm
<b>Class</b>	II
<b>CRI</b>	>80
<b>Voltage (V/Hz)</b>	100V-240V/50-60Hz

## Rob Shade

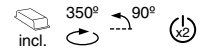

- 68496   Bronze + Opal
- 68498   Satin Nickel + Opal

<b>Material</b>	<b>Body</b> Steel+Aluminium
	<b>Shade</b> PMMA
<b>Light Source</b>	1 E27 max. 15W
<b>Bulb incl.</b>	No
<b>Reader</b>	3W, 3000K, 160lm
<b>Driver incl.</b>	Yes
<b>Class</b>	I
<b>Voltage (V/Hz)</b>	100V-240V/50-60Hz

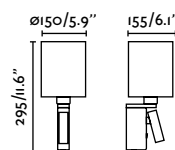
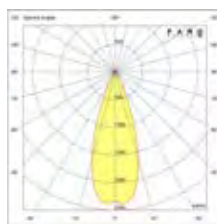
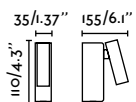

Rob

indoor

Surface



Rob Ref. 68497

Thanks to Dario Fernandez and Corso Estudio | Photo by Juan de los Mares

## Loke

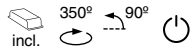

- 40994-110  Chrome
- 41019-110  Matt White
- 41020-110  Matt Black

<b>Material</b>	Body Aluminium+Steel
<b>Power</b>	3W
<b>Lumen Output</b>	150lm
<b>Light Source</b>	HIGH POWER LED 3000K
<b>Reader</b>	3W, 3000K, 150lm
<b>Class</b>	II
<b>CRI</b>	>80
<b>Voltage (V/Hz)</b>	110V/50-60Hz
<b>Beam angle</b>	30°

## Loke recessed

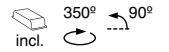

- 40996-110  Chrome

<b>Material</b>	Body Aluminium+Steel
<b>Power</b>	3W
<b>Lumen Output</b>	150lm
<b>Light Source</b>	HIGH POWER LED 3000K
<b>Class</b>	II
<b>CRI</b>	>80
<b>Voltage (V/Hz)</b>	110V/50-60Hz
<b>Beam angle</b>	30°
<b>Cut out</b>	ø60

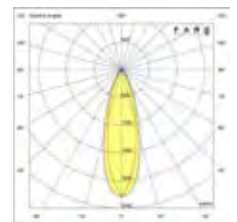
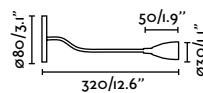
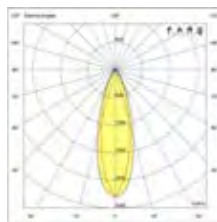
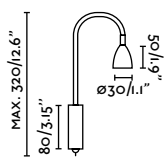



# Loke

indoor

Surface



Loke Ref. 41019-110



## Boc

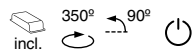

- 62707-110  Matt White
- 62708-110  Matt Black
- 62710-110  Chrome
- 62711-110  Bronze

<b>Material</b>	Body Steel
<b>Power</b>	3W
<b>Lumen Output</b>	130lm
<b>Light Source</b>	HIGH POWER LED 3000K
<b>Reader</b>	3W, 3000K, 130lm
<b>Class</b>	II
<b>CRI</b>	>80
<b>Voltage (V/Hz)</b>	110V/50-60Hz

## Flin

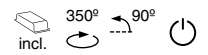

- 64318  Matt White
- 64319  Matt Black

<b>Material</b>	Body Steel+Aluminium+Silicone
<b>Power</b>	3W
<b>Lumen Output</b>	280lm
<b>Light Source</b>	HIGH POWER LED 3000K
<b>Reader</b>	3W, 3000K, 280lm
<b>Class</b>	I
<b>CRI</b>	>80
<b>Voltage (V/Hz)</b>	100V-240V/50-60Hz
<b>Beam angle</b>	30°

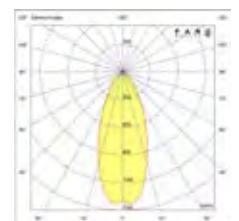
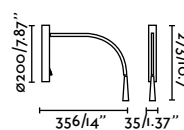
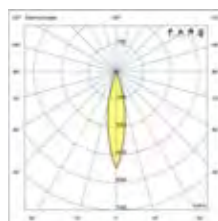
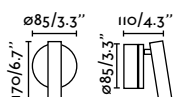

Boc

indoor

Surface



**Studio**  
Nahtrang



- 51133  Matt Black
- 51134  Chrome
- 51135  Shiny White

<b>Material</b>	Body Aluminium+ABS
<b>Light Source</b>	1 E14 max. 8W
<b>Bulb incl.</b>	No
<b>Class</b>	II
<b>Voltage (V/Hz)</b>	100V-240V/50-60Hz
<b>Cable</b>	1.6 MT



**Accessories**

- 51129  Black

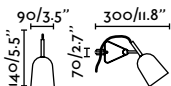
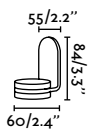

indoor

Surface

# Studio

Designed by Nahrang



Studio Ref. 51135

## Pepper

360° 180° 180°



- 64168 ● Beige
- 64169 ● Matt Black

<b>Material</b>	Body Steel
<b>Light Source</b>	1 E27 max. 15W
<b>Bulb incl.</b>	No
<b>Class</b>	II
<b>Voltage (V/Hz)</b>	100V-240V/50-60Hz
<b>Cable</b>	1.7 MT

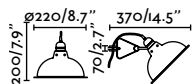



Pepper

indoor

Surface



## Juliet



41025N

Chrome

<b>Material</b>	<b>Body</b> Aluminium+Steel
<b>Power</b>	3W
<b>Lumen Output</b>	150lm
<b>Light Source</b>	SMD LED 3000K
<b>Reader</b>	3W, 3000K, 150lm
<b>Class</b>	II
<b>CRI</b>	>80
<b>Voltage (V/Hz)</b>	100V-240V/50-60Hz
<b>Beam angle</b>	30°

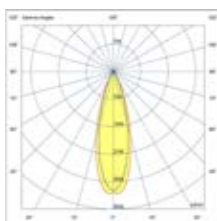
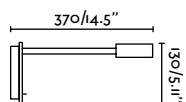



# Kale



62703

● Matt Black

<b>Material</b>	<b>Body</b> Aluminium+Steel+Silicone
<b>Power</b>	3W
<b>Lumen Output</b>	180lm
<b>Light Source</b>	HIGH POWER LED 3000K
<b>Reader</b>	3W, 3000K, 180lm
<b>Class</b>	II
<b>CRI</b>	>80
<b>Voltage (V/Hz)</b>	100V-240V/50-60Hz
<b>Beam angle</b>	45°

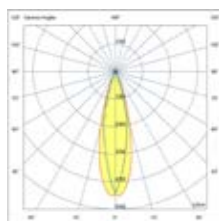
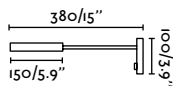

# Kale

indoor

Surface





## Sami



41023-110 ● Matt White

<b>Material</b>	<b>Body</b> Aluminium+Steel+Silicone
<b>Power</b>	3W
<b>Lumen Output</b>	120lm
<b>Light Source</b>	HIGH POWER LED 2700K
<b>Class</b>	II
<b>CRI</b>	>80
<b>Voltage (V/Hz)</b>	110V/50-60Hz
<b>Beam angle</b>	30°

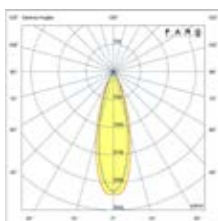
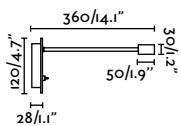

Sami

indoor

Surface



Sami Ref. 41023-110

439

## Lead



62704-110

●● Old Gold + Brown

<b>Material</b>	<b>Body</b> Aluminium+Leather
<b>Power</b>	3W
<b>Lumen Output</b>	180lm
<b>Light Source</b>	COB LED 3000K
<b>Reader</b>	3W, 4000K, 300lm
<b>Class</b>	II
<b>CRI</b>	>80
<b>Voltage (V/Hz)</b>	110V/50-60Hz
<b>Beam angle</b>	45°

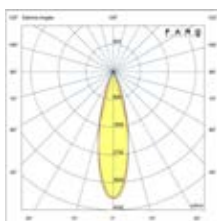
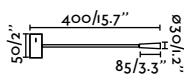

indoor

Surface



**Pixie**  
Nahtrng



- 24015  Matt White
- 24016  Matt Black

<b>Material</b>	Body Aluminium
<b>Power</b>	4W
<b>Lumen Output</b>	107lm
<b>Light Source</b>	HIGH POWER LED 2700K
<b>Reader</b>	3W, 2700K, 90lm
<b>Class</b>	II
<b>CRI</b>	>80
<b>Voltage (V/Hz)</b>	100V-240V/50-60Hz
<b>Beam angle</b>	45°

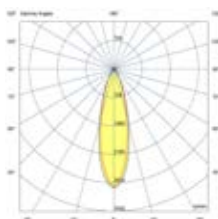
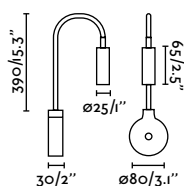





**Suau recessed**  
Nahtrang

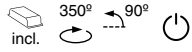

- 62111 ● Bronze
- 62114 ● Satin Gold
- 62126 ● Satin Nickel
- 62128 ● Matt Black
- 62129 ● Matt White

<b>Material</b>	<b>Body Aluminium+Steel</b>
<b>Power</b>	3W
<b>Lumen Output</b>	140lm
<b>Light Source</b>	HIGH POWER LED 3000K
<b>Reader</b>	3W, 3000K, 140lm
<b>Class</b>	I
<b>CRI</b>	>80
<b>Voltage (V/Hz)</b>	100V-240V/50-60Hz
<b>Beam angle</b>	30°
<b>Cut out</b>	80x155x43

**Suau USB**  
Nahtrang

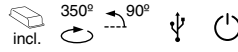

- 62116 ● Matt Black
- 62117 ● Matt White

<b>Material</b>	<b>Body Aluminium+Steel</b>
<b>Power</b>	3W
<b>Lumen Output</b>	140lm
<b>Light Source</b>	HIGH POWER LED 3000K
<b>Reader</b>	3W, 3000K, 140lm
<b>Class</b>	I
<b>CRI</b>	>80
<b>Voltage (V/Hz)</b>	100V-240V/50-60Hz
<b>Beam angle</b>	30°

**Suau**  
Nahtrang

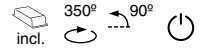

- 62104 ● Bronze
- 62118 ● Matt Black
- 62120 ● Matt White
- 62121 ● Grey

<b>Material</b>	<b>Body Aluminium+Steel</b>
<b>Power</b>	3W
<b>Lumen Output</b>	140lm
<b>Light Source</b>	HIGH POWER LED 3000K
<b>Reader</b>	3W, 3000K, 140lm
<b>Class</b>	I
<b>CRI</b>	>80
<b>Voltage (V/Hz)</b>	100V-240V/50-60Hz
<b>Beam angle</b>	30°

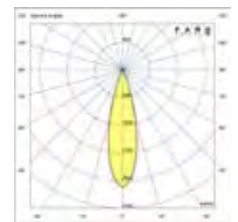
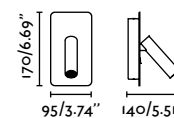
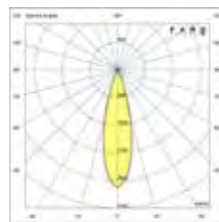
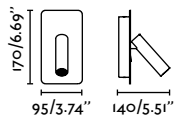
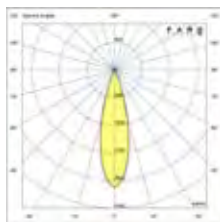
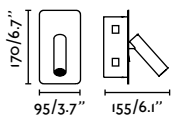

# Suau

Designed by Nahtrang

indoor

Surface

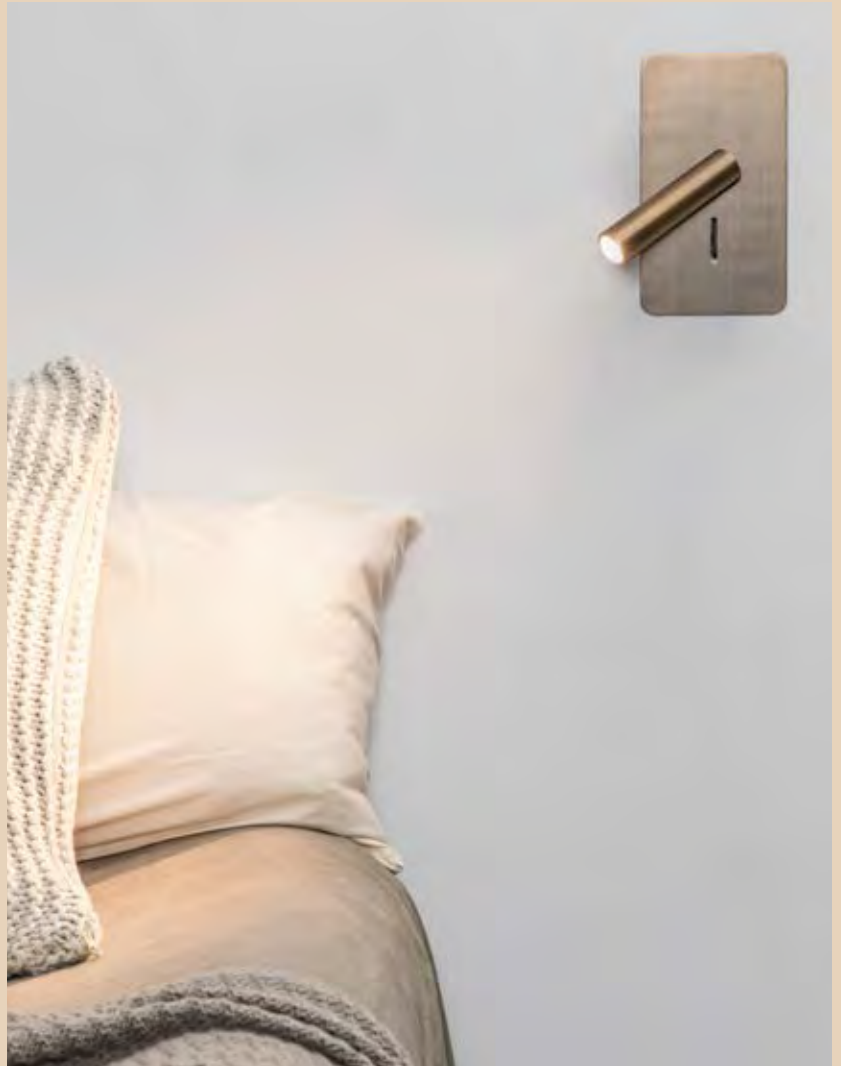

Suau recessed Ref. 62111



**Suau tray left**  
Nahtrang

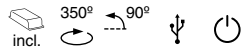

- 62124  Matt White
- 62125  Grey

<b>Material</b>	<b>Body</b> Aluminium+Steel
<b>Power</b>	3W
<b>Lumen Output</b>	140lm
<b>Light Source</b>	HIGH POWER LED 3000K
<b>Reader</b>	3W, 3000K, 140lm
<b>Class</b>	I
<b>CRI</b>	>80
<b>Voltage (V/Hz)</b>	100V-240V/50-60Hz
<b>Beam angle</b>	30°

**Suau tray right**  
Nahtrang

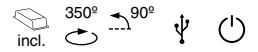

- 62122  Matt White
- 62123  Grey

<b>Material</b>	<b>Body</b> Aluminium+Steel
<b>Power</b>	3W
<b>Lumen Output</b>	140lm
<b>Light Source</b>	HIGH POWER LED 3000K
<b>Reader</b>	3W, 3000K, 140lm
<b>Class</b>	I
<b>CRI</b>	>80
<b>Voltage (V/Hz)</b>	100V-240V/50-60Hz
<b>Beam angle</b>	30°

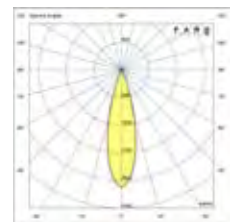
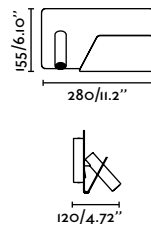
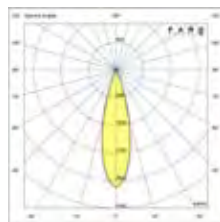
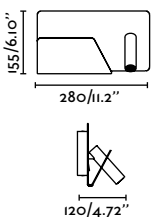





Suau tray right Ref. 62123



**Tila**  
Estudi Ribaudí

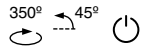

62360 ● Cream White  
62361 ● Black

**Noon**  
Alegre Design

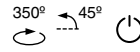

62355 ● Matt White

**Smile**  
Jordi Busquets

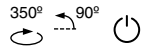

62130 ● Matt White  
62131 ● Matt Black

<b>Material</b>	<b>Body Steel</b>
	<b>Shade Steel</b>
<b>Light Source</b>	1 E27 G45 max. 15W
<b>Bulb incl.</b>	No
<b>Class</b>	II
<b>Voltage (V/Hz)</b>	100V-240V/50-60Hz

<b>Material</b>	<b>Body Steel</b>
	<b>Shade Steel</b>
<b>Light Source</b>	1 E27 max. 15W
<b>Bulb incl.</b>	No
<b>Class</b>	II
<b>Voltage (V/Hz)</b>	100V-240V/50-60Hz

<b>Material</b>	<b>Body Steel</b>
<b>Light Source</b>	1 E27 max. 15W
<b>Bulb incl.</b>	No
<b>Class</b>	II
<b>Voltage (V/Hz)</b>	100V-240V/50-60Hz

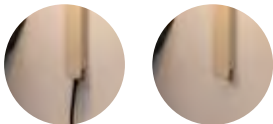

2 Installation Modes



2 Installation Modes

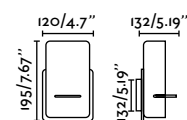
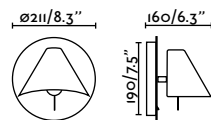
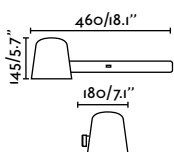

indoor

Surface

# Tila, Noon & Smile



Tila Ref. 62360



Noon Ref. 62355  
Thanks to MIKMAX

**Nit Left**  
Goula / Figuera



01004 ● Matt Black

**Nit right**  
Goula / Figuera



01006 ● Matt Black

<b>Material</b>	Body Steel
<b>Light Source</b>	1 E27 max. 15W
<b>Bulb incl.</b>	No
<b>Class</b>	II
<b>Voltage (V/Hz)</b>	100V-240V/50-60Hz
<b>Cable</b>	1.7 MT

<b>Material</b>	Body Steel
<b>Light Source</b>	1 E27 max. 15W
<b>Bulb incl.</b>	No
<b>Class</b>	II
<b>Voltage (V/Hz)</b>	100V-240V/50-60Hz
<b>Cable</b>	1.7 MT

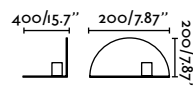
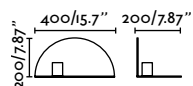

# Nit

Designed by Goula/Figuera



One side is fixed to the wall, while the other side can be used as a shelf.

It doesn't get any more comfortable.



Nit right Ref. 01006

## Well induction



64030 ● Matt White

<b>Material</b>	<b>Body</b> Aluminium+PP
	<b>Diff</b> Opal PMMA
<b>Power</b>	7W
<b>Lumen Output</b>	340lm
<b>Light Source</b>	SMD LED 2700K
<b>Class</b>	I
<b>CRI</b>	>=90
<b>Voltage (V/Hz)</b>	100V-240V/50Hz

## Corb



40135 ● Matt White  
40136 ● Matt Black

<b>Material</b>	<b>Body</b> Aluminium
<b>Light Source</b>	1 GU10 max. 8W
<b>Bulb incl.</b>	No
<b>Class</b>	I
<b>Voltage (V/Hz)</b>	100V-240V/50-60Hz

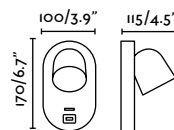
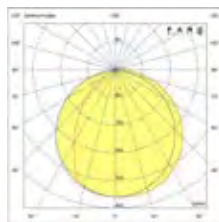
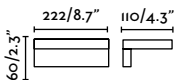



# Well & Corb



Corb Ref. 40135

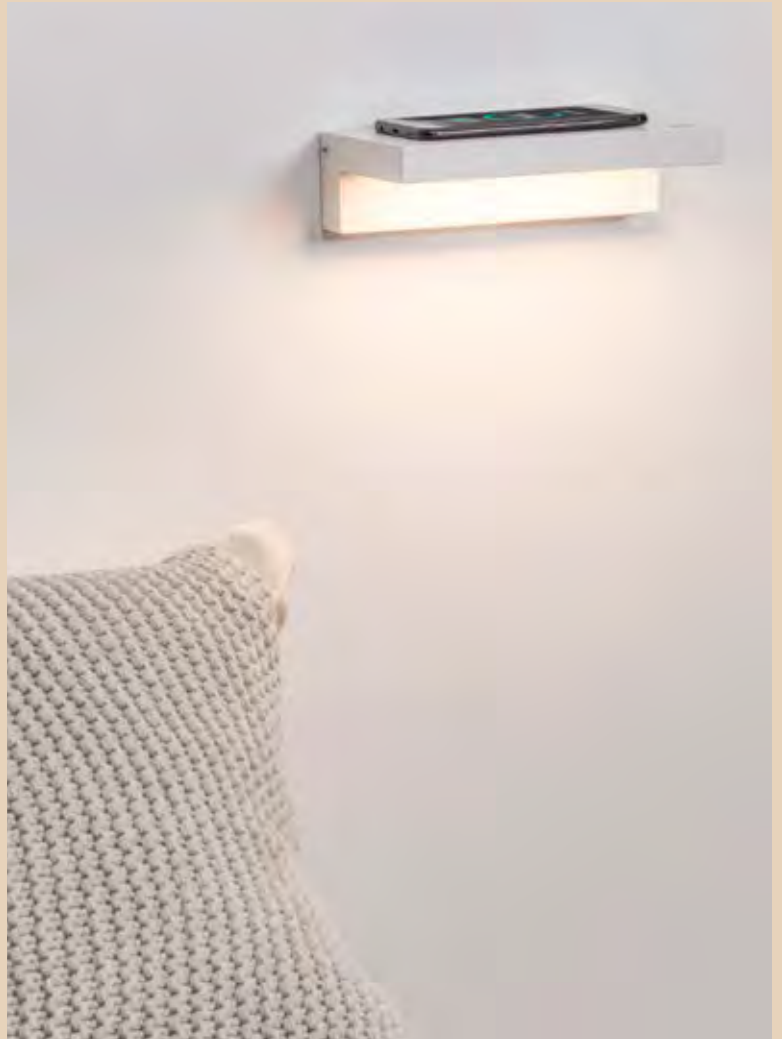

Well induction Ref. 64030

**Eres**  
Àlex & Manel Llusçà



64026 ● Matt White

<b>Material</b>	Body Steel
<b>Light Source</b>	1 E27 max. 15W
<b>Bulb incl.</b>	No
<b>Class</b>	I
<b>Voltage (V/Hz)</b>	100V-240V/50-60Hz

**Ovo 190**  
Estudi Ribaudí

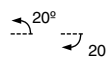

62105 ● Matt White

<b>Material</b>	Body Steel
<b>Light Source</b>	1 R7S 78mm max. 8W
<b>Bulb incl.</b>	No
<b>Class</b>	I
<b>Voltage (V/Hz)</b>	100V-240V/50-60Hz

**Ovo 240**  
Estudi Ribaudí

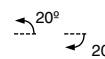

62108 ● Matt White

<b>Material</b>	Body Steel
<b>Light Source</b>	1 R7S 118mm max. 15W
<b>Bulb incl.</b>	No
<b>Class</b>	I
<b>Voltage (V/Hz)</b>	100V-240V/50-60Hz

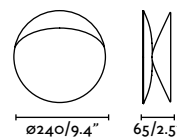
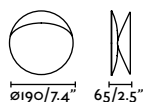
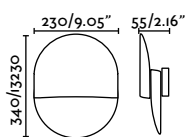

indoor

Surface

# Eres

Designed by Àlex & Manel Lluscà



Eres Ref. 64026

Thanks to Estudio Reciente | Photo by Asier Rua

### Otton RCT vertical



- 66400-97  Matt White + Linen
- 66400-98  Matt White + Jute

### Otton R vertical



- 66400-101  Matt White + Linen
- 66400-102  Matt White + Jute

### Otton SQ 200



- 66400-105  Matt White + Linen
- 66400-106  Matt White + Jute

<b>Material</b>	<b>Body Steel</b>
	<b>Shade Linen/ Jute</b>
<b>Light Source</b>	1 E27 max. 15W
<b>Bulb incl.</b>	No
<b>Class</b>	I
<b>Voltage (V/Hz)</b>	100V-240V/50-60Hz

<b>Material</b>	<b>Body Steel</b>
	<b>Shade Linen/ Jute</b>
<b>Light Source</b>	1 E27 max. 15W
<b>Bulb incl.</b>	No
<b>Class</b>	I
<b>Voltage (V/Hz)</b>	100V-240V/50-60Hz

<b>Material</b>	<b>Body Steel</b>
	<b>Shade Linen/ Jute</b>
<b>Light Source</b>	1 E27 max. 15W
<b>Bulb incl.</b>	No
<b>Class</b>	I
<b>Voltage (V/Hz)</b>	100V-240V/50-60Hz

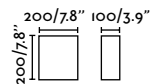
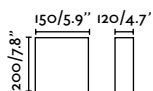
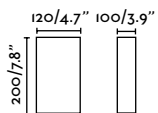

Otton





## Otton RCT vertical 2L



- 66401-99  Matt White + Linen
- 66401-100  Matt White + Jute

<b>Material</b>	<b>Body Steel</b>
	<b>Shade Linen/ Jute</b>
<b>Light Source</b>	2 E27 max. 15W
<b>Bulb incl.</b>	No
<b>Class</b>	I
<b>Voltage (V/Hz)</b>	100V-240V/50-60Hz

## Otton R vertical 2L



- 66401-103  Matt White + Linen
- 66401-104  Matt White + Jute

<b>Material</b>	<b>Body Steel</b>
	<b>Shade Linen/ Jute</b>
<b>Light Source</b>	2 E27 max. 15W
<b>Bulb incl.</b>	No
<b>Class</b>	I
<b>Voltage (V/Hz)</b>	100V-240V/50-60Hz

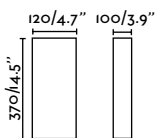

**Otton RCT Horizontal 2L**

**Otton R Horizontal 2L**



- 66401-107  Matt White + Linen
- 66401-108  Matt White + Jute

- 66401-109  Matt White + Linen
- 66401-110  Matt White + Jute

<b>Material</b>	<b>Body</b> Steel
	<b>Shade</b> Linen/ Jute
<b>Light Source</b>	2 E27 max. 15W
<b>Bulb incl.</b>	No
<b>Class</b>	I
<b>Voltage (V/Hz)</b>	100V-240V/50-60Hz

<b>Material</b>	<b>Body</b> Steel
	<b>Shade</b> Linen/ Jute
<b>Light Source</b>	2 E27 max. 15W
<b>Bulb incl.</b>	No
<b>Class</b>	I
<b>Voltage (V/Hz)</b>	100V-240V/50-60Hz

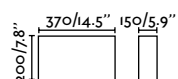
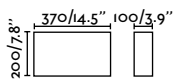

Cotton RCT vertical 2L



- 66405  Matt White + Beige
- 66406   Matt White + Black

Cotton R vertical



- 66407  Matt White + Beige
- 66408   Matt White + Black

Cotton R vertical 2L



- 66409  Matt White + Beige
- 66410   Matt White + Black

<b>Material</b>	<b>Body Steel</b>
	<b>Shade Textile</b>
<b>Light Source</b>	2 E27 max. 15W
<b>Bulb incl.</b>	No
<b>Class</b>	I
<b>Voltage (V/Hz)</b>	100V-240V/50-60Hz

<b>Material</b>	<b>Body Steel</b>
	<b>Shade Textile</b>
<b>Light Source</b>	1 E27 max. 15W
<b>Bulb incl.</b>	No
<b>Class</b>	I
<b>Voltage (V/Hz)</b>	100V-240V/50-60Hz

<b>Material</b>	<b>Body Steel</b>
	<b>Shade Textile</b>
<b>Light Source</b>	2 E27 max. 15W
<b>Bulb incl.</b>	No
<b>Class</b>	I
<b>Voltage (V/Hz)</b>	100V-240V/50-60Hz

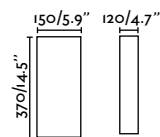
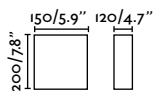
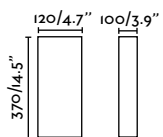

Cotton

indoor

Surface



## Cotton RCT vertical



- 66403  Matt White + Beige
- 66404   Matt White + Black

<b>Material</b>	<b>Body</b> Steel
	<b>Shade</b> Textile
<b>Light Source</b>	1 E27 max. 15W
<b>Bulb incl.</b>	No
<b>Class</b>	I
<b>Voltage (V/Hz)</b>	100V-240V/50-60Hz

## Cotton SQ 200



- 66411  Matt White + Beige
- 66412   Matt White + Black

<b>Material</b>	<b>Body</b> Steel
	<b>Shade</b> Textile
<b>Light Source</b>	1 E27 max. 15W
<b>Bulb incl.</b>	No
<b>Class</b>	I
<b>Voltage (V/Hz)</b>	100V-240V/50-60Hz

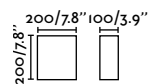
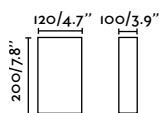



**Cotton RCT Horizontal 2L**



- 66413  Matt White + Beige
- 66414   Matt White + Black

<b>Material</b>	<b>Body</b> Steel
	<b>Shade</b> Textile
<b>Light Source</b>	2 E27 max. 15W
<b>Bulb incl.</b>	No
<b>Class</b>	I
<b>Voltage (V/Hz)</b>	100V-240V/50-60Hz

**Cotton R Horizontal 2L**



- 66415  Matt White + Beige
- 66416   Matt White + Black

<b>Material</b>	<b>Body</b> Steel
	<b>Shade</b> Textile
<b>Light Source</b>	2 E27 max. 15W
<b>Bulb incl.</b>	No
<b>Class</b>	I
<b>Voltage (V/Hz)</b>	100V-240V/50-60Hz

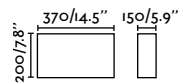
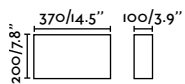

**Ten 140**  
Faro Lab



- 62170  Matt White
- 62171  Matt Black
- 62172  Old Gold

<b>Material</b>	Body Aluminium
<b>Light Source</b>	1 E27 max. 15W
<b>Bulb incl.</b>	No
<b>Class</b>	II
<b>Voltage (V/Hz)</b>	100V-240V/50-60Hz

**Ten 70**  
Faro Lab



- 62150  Matt White
- 62151  Matt Black
- 62152  Old Gold
- 62153  Satin Gold
- 62154  Shiny Copper
- 62155  Satin Nickel

<b>Material</b>	Body Aluminium
<b>Light Source</b>	1 E27 max. 15W
<b>Bulb incl.</b>	No
<b>Class</b>	II
<b>Voltage (V/Hz)</b>	100V-240V/50-60Hz



Table  
102

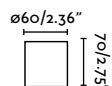
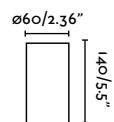

# Ten

Designed by Faro Lab



## Homs

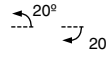

63167

● Matt White

## Kera



62300

● Shiny White

62301

● Shiny Black

## Sera



62302

● Shiny White

62303

● Shiny Black

<b>Material</b>	<b>Body Steel</b>
<b>Light Source</b>	1 R7S 78mm max. 8W
<b>Bulb incl.</b>	No
<b>Class</b>	I
<b>Voltage (V/Hz)</b>	100V-240V/50-60Hz

<b>Material</b>	<b>Body Ceramic</b>
<b>Light Source</b>	1 E27 max. 15W
<b>Bulb incl.</b>	No
<b>Class</b>	II
<b>Voltage (V/Hz)</b>	100V-240V/50-60Hz

<b>Material</b>	<b>Body Ceramic</b>
<b>Light Source</b>	1 E27 max. 15W
<b>Bulb incl.</b>	No
<b>Class</b>	II
<b>Voltage (V/Hz)</b>	100V-240V/50-60Hz

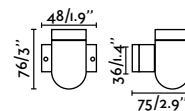
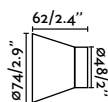
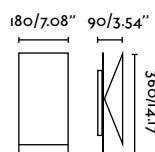



Homs

indoor

Surface





## Loa



62809

● Matt Black

<b>Material</b>	<b>Body Steel</b>
	<b>Shade Steel</b>
<b>Light Source</b>	1 E27 max. 15W
<b>Bulb incl.</b>	No
<b>Class</b>	I
<b>Voltage (V/Hz)</b>	100V-240V/50-60Hz

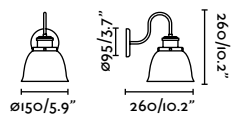

## Hudson



62810

● Shiny Black

<b>Material</b>	<b>Body Steel</b>
	<b>Diff Transparent Glass</b>
<b>Light Source</b>	1 E27 max. 15W
<b>Bulb incl.</b>	No
<b>Class</b>	I
<b>Voltage (V/Hz)</b>	100V-240V/50-60Hz

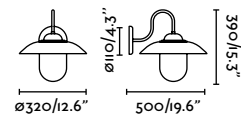

# Hudson



## Celia



40070

● Matt Black

<b>Material</b>	<b>Body</b> Steel
	<b>Shade</b> Steel
<b>Light Source</b>	1 E14 max. 8W
<b>Bulb incl.</b>	No
<b>Class</b>	II
<b>Voltage (V/Hz)</b>	100V-240V/50-60Hz
<b>Cable</b>	1.8 MT

## Marlin



65133

●● Matt Black + Old Gold

<b>Material</b>	<b>Body</b> Steel
	<b>Shade</b> Steel
<b>Light Source</b>	1 E27 max. 15W
<b>Bulb incl.</b>	No
<b>Class</b>	I
<b>Voltage (V/Hz)</b>	100V-240V/50-60Hz



Suspended  
258

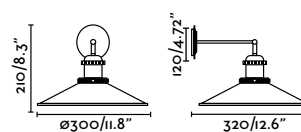
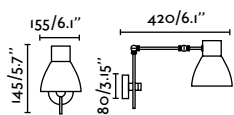



# Celia

indoor

Surface



Celia Ref. 40070

471

**Ras**

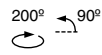

**Snap**  
Faro Lab

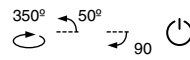

**List**

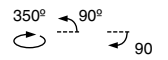

62807 ● Shiny Black



57402 ● Cream White  
57403 ● Dark Grey



60000 ● Matt Black

<b>Material</b>	Body Steel
<b>Light Source</b>	1 E27 max. 15W
<b>Bulb incl.</b>	No
<b>Class</b>	I
<b>Voltage (V/Hz)</b>	100V-240V/50-60Hz
<b>Cable</b>	3 MT

<b>Material</b>	Body Steel
<b>Light Source</b>	1 E27 max. 15W
<b>Bulb incl.</b>	No
<b>Class</b>	II
<b>Voltage (V/Hz)</b>	100V-240V/50-60Hz

<b>Material</b>	Body Steel
<b>Light Source</b>	1 E27 max. 15W
<b>Bulb incl.</b>	No
<b>Class</b>	II
<b>Voltage (V/Hz)</b>	100V-240V/50-60Hz



Table  
118

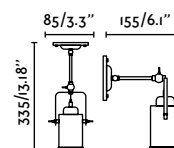
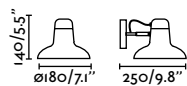
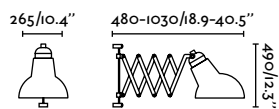



List

indoor

Surface



**Linda**  
Estudi Ribaudí



- 29306  Matt White + Beige
- 29310  Matt Black + Beige

<b>Material</b>	<b>Body</b> Steel
	<b>Shade</b> Textile
<b>Light Source</b>	2 E27 max. 15W
<b>Bulb incl.</b>	No
<b>Class</b>	I
<b>Voltage (V/Hz)</b>	100V-240V/50-60Hz



**Suspended Table&Floor**  
246 154

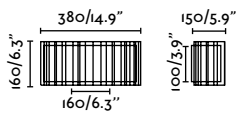

**Retro**  
Àlex & Manel Llusçà

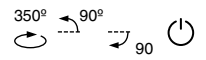

- 20045   Matt Copper + Matt Black
- 20049   Matt Black + Chrome

<b>Material</b>	<b>Body</b> Steel
<b>Light Source</b>	1 E14 max. 8W
<b>Bulb incl.</b>	No
<b>Class</b>	I
<b>Voltage (V/Hz)</b>	100V-240V/50-60Hz



**Suspended**  
206

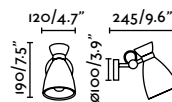

# Retro

Designed by Àlex & Manel Lluscà

indoor

Surface



Retro Ref. 20045

Thanks to Adeline Pithois-Guillou | Photo by aguillouphotography

**Tou 350**  
Faro Lab

incl.



01207 ● Grey

<b>Material</b>	<b>Body</b> Aluminium+Foam
	<b>Diff</b> Opal PMMA
	<b>Shade</b> Textile
<b>Power</b>	7W
<b>Lumen Output</b>	450lm
<b>Light Source</b>	SMD LED 2700K
<b>Class</b>	I
<b>CRI</b>	>80
<b>Voltage (V/Hz)</b>	100V-240V/50-60Hz

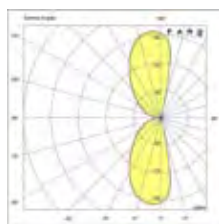
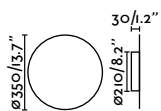

**Tou 450**  
Faro Lab

incl.



01206 ● Bordeaux  
01208 ● Grey

<b>Material</b>	<b>Body</b> Aluminium+Foam
	<b>Diff</b> Opal PMMA
	<b>Shade</b> Textile
<b>Power</b>	10W
<b>Lumen Output</b>	750lm
<b>Light Source</b>	SMD LED 2700K
<b>Class</b>	I
<b>CRI</b>	>80
<b>Voltage (V/Hz)</b>	100V-240V/50-60Hz

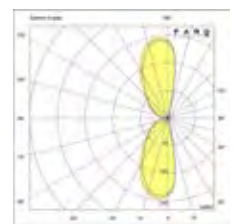
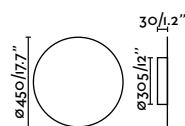

indoor

Surface

# Tou

Designed by Faro Lab

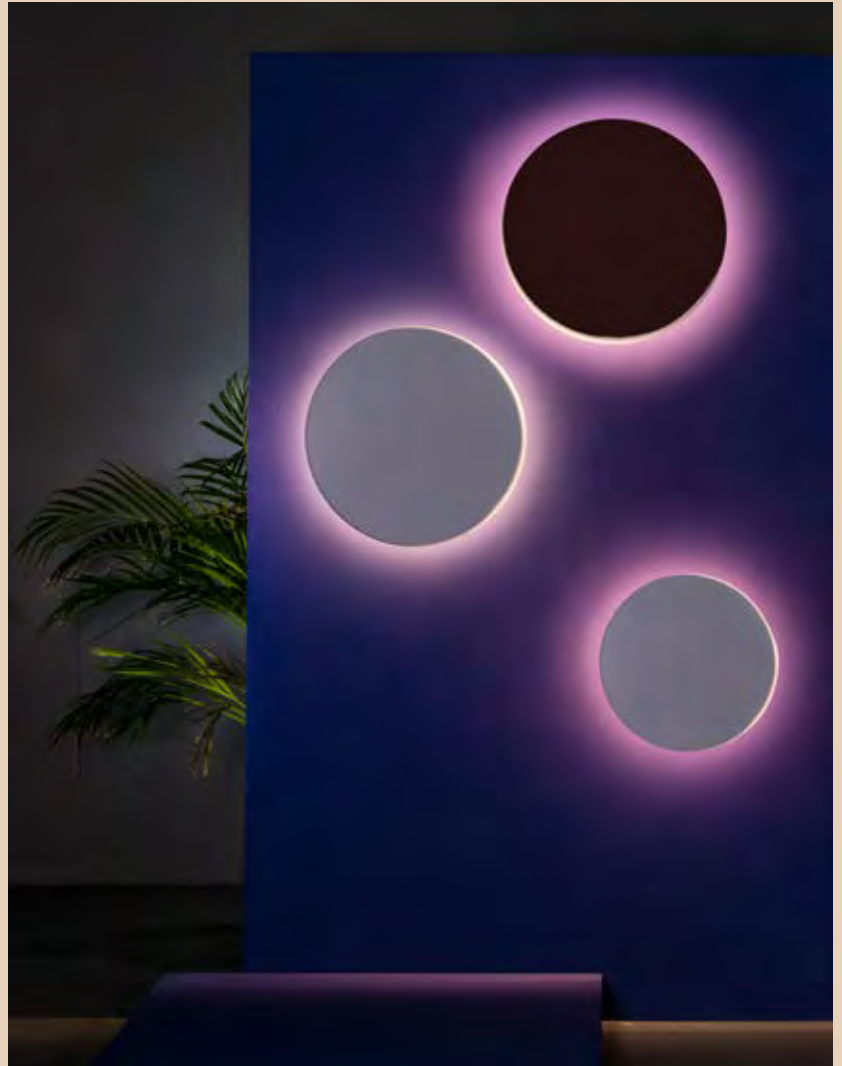



## Board 350

incl. 



01040-110 ● Blackboard

<b>Material</b>	<b>Body Steel</b>
	<b>Diff Opal PMMA</b>
<b>Power</b>	8W
<b>Lumen Output</b>	218lm
<b>Light Source</b>	SMD LED 2700K
<b>Class</b>	I
<b>CRI</b>	>80
<b>Voltage (V/Hz)</b>	110V/50-60Hz

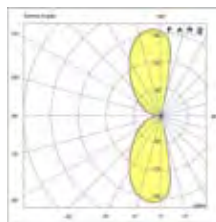
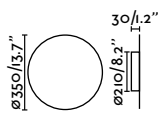

## Board 450

incl. 



01041 ● Blackboard

<b>Material</b>	<b>Body Steel</b>
	<b>Diff Opal PMMA</b>
<b>Power</b>	12W
<b>Lumen Output</b>	327lm
<b>Light Source</b>	SMD LED 2700K
<b>Class</b>	I
<b>CRI</b>	>80
<b>Voltage (V/Hz)</b>	100V-240V/50-60Hz

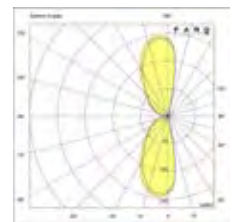
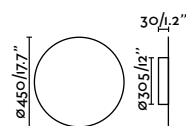

# Board

indoor

Surface



## Stan

NEW



- 43748  Matt White
- 43749  Matt Black
- 43759  Satin Gold
- 43765  Terracotta

<b>Material</b>	Body Aluminium
<b>Light Source</b>	1 GU10 max. 5W
<b>Bulb incl.</b>	No
<b>Class</b>	I
<b>Voltage (V/Hz)</b>	100V-240V/50-60Hz

## Stan 2L

NEW



- 43750  Matt White
- 43751  Matt Black
- 43760  Satin Gold
- 43766  Terracotta

<b>Material</b>	Body Aluminium
<b>Light Source</b>	2 GU10 max. 5W
<b>Bulb incl.</b>	No
<b>Class</b>	I
<b>Voltage (V/Hz)</b>	100V-240V/50-60Hz

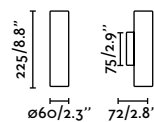
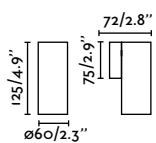

Stan

indoor

Surface



Stan Ref. 43766

481

## Nash 210



- 62821-110  Matt Black
- 62819-110  Matt White

<b>Material</b>	<b>Body</b> Aluminium
	<b>Diff</b> Opal PC
<b>Power</b>	8W
<b>Lumen Output</b>	450lm
<b>Light Source</b>	SMD LED 3000K
<b>Class</b>	I
<b>CRI</b>	>80
<b>Voltage (V/Hz)</b>	110V/50-60Hz

## Nash 370



- 62820-110  Matt White
- 62822-110  Matt Black

<b>Material</b>	<b>Body</b> Aluminium
	<b>Diff</b> Opal PC
<b>Power</b>	16W
<b>Lumen Output</b>	990lm
<b>Light Source</b>	SMD LED 3000K
<b>Class</b>	I
<b>CRI</b>	>80
<b>Voltage (V/Hz)</b>	110V/50-60Hz

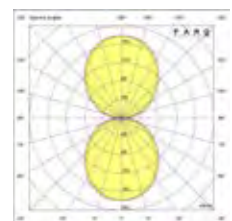
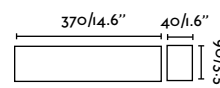
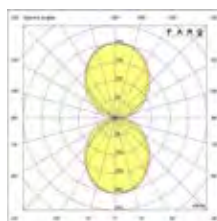
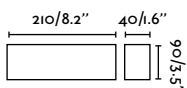



# Nash

indoor

Surface



## Oslo



63284

● Matt White

<b>Material</b>	Body Plaster
<b>Light Source</b>	1 G9 max. 6W
<b>Bulb incl.</b>	No
<b>Class</b>	I
<b>Voltage (V/Hz)</b>	100V-240V/50-60Hz

## Olaf



63278

● Matt White

<b>Material</b>	Body Plaster
	Diff Opal PC
<b>Light Source</b>	2 E14 max. 8W
<b>Bulb incl.</b>	No
<b>Class</b>	I
<b>Voltage (V/Hz)</b>	100V-240V/50-60Hz

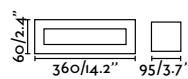
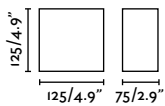

indoor

Surface

# Oslo

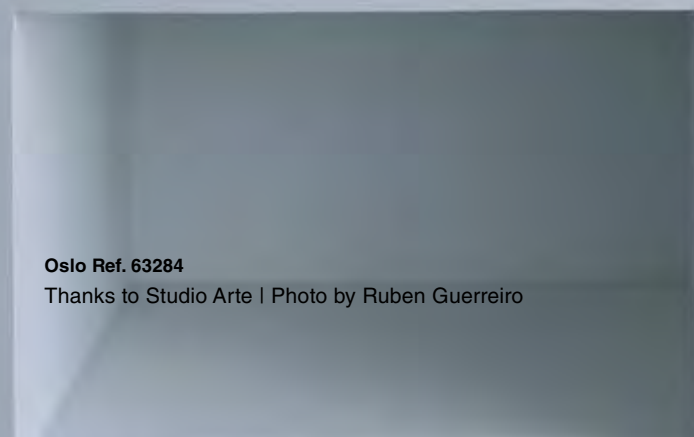

Oslo Ref. 63284

Thanks to Studio Arte | Photo by Ruben Guerreiro

## Cheras 2



63173

● Matt White

<b>Material</b>	<b>Body Plaster</b>
	<b>Diff Opal White Glass</b>
<b>Light Source</b>	1 R7S 78mm max. 8W
<b>Bulb incl.</b>	No
<b>Class</b>	I
<b>Voltage (V/Hz)</b>	100V-240V/50-60Hz

## Cheras 3



63174

● Matt White

<b>Material</b>	<b>Body Plaster</b>
	<b>Diff Opal White Glass</b>
<b>Light Source</b>	1 G9 max. 6W
<b>Bulb incl.</b>	No
<b>Class</b>	I
<b>Voltage (V/Hz)</b>	100V-240V/50-60Hz

## Cheras 4



63175

● Matt White

<b>Material</b>	<b>Body Plaster</b>
	<b>Diff Opal White Glass</b>
<b>Light Source</b>	1 R7S 78mm max. 8W
<b>Bulb incl.</b>	No
<b>Class</b>	I
<b>Voltage (V/Hz)</b>	100V-240V/50-60Hz

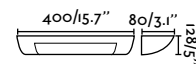
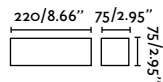
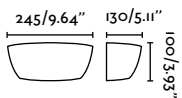

# Cheras

indoor

Surface





### Eaco 1



63176

● Matt White

### Eaco 2



63177

● Matt White

### Eaco 3



63178

● Matt White

<b>Material</b>	Body Plaster
<b>Light Source</b>	1 G9 max. 6W
<b>Bulb incl.</b>	No
<b>Class</b>	I
<b>Voltage (V/Hz)</b>	100V-240V/50-60Hz

<b>Material</b>	Body Plaster
<b>Light Source</b>	2 G9 max. 6W
<b>Bulb incl.</b>	No
<b>Class</b>	I
<b>Voltage (V/Hz)</b>	100V-240V/50-60Hz

<b>Material</b>	Body Plaster
<b>Light Source</b>	1 R7S 78mm max. 8W
<b>Bulb incl.</b>	No
<b>Class</b>	I
<b>Voltage (V/Hz)</b>	100V-240V/50-60Hz

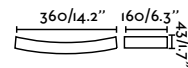
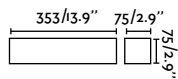
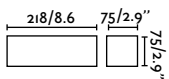

Eaco

indoor

Surface



## Snow



63285

● Matt White

<b>Material</b>	Body Plaster
<b>Light Source</b>	1 E14 max. 8W
<b>Bulb incl.</b>	No
<b>Class</b>	I
<b>Voltage (V/Hz)</b>	100V-240V/50-60Hz

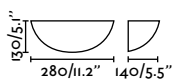

## Elsa

incl.



63279-110

● Matt White

<b>Material</b>	Body Plaster
	Diff Opal PC
<b>Power</b>	8W
<b>Lumen Output</b>	300lm
<b>Light Source</b>	SMD LED 3000K
<b>Class</b>	II
<b>CRI</b>	>80
<b>Voltage (V/Hz)</b>	110V/50-60Hz

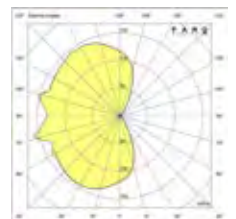
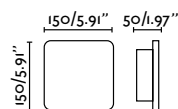

# Snow



## Kamen



- 63311  Beige
- 63312  Grey

<b>Material</b>	<b>Body Concrete</b>
<b>Light Source</b>	1 G9 max. 6W
<b>Bulb incl.</b>	No
<b>Class</b>	I
<b>Voltage (V/Hz)</b>	100V-240V/50-60Hz

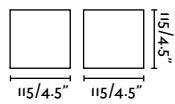

## Luna

incl.



- 63225-110  Matt White

<b>Material</b>	<b>Body Plaster</b>
	<b>Diff Opal PMMA</b>
<b>Power</b>	5W
<b>Lumen Output</b>	300lm
<b>Light Source</b>	SMD LED 2700K
<b>Class</b>	II
<b>CRI</b>	>80
<b>Voltage (V/Hz)</b>	110V/50-60Hz

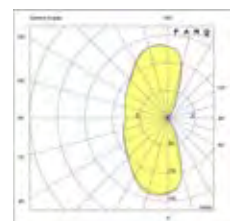
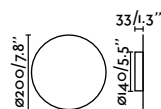



indoor

Surface

# Luna



Luna Ref. 63225-110  
Thanks to BSP Alfombras

## Magritte 300



- 61080  Satin Nickel
- 61083  Old Gold
- 61086  Matt Black

<b>Material</b>	<b>Body</b> Aluminium+Steel
	<b>Diff</b> PMMA
<b>Power</b>	6W
<b>Lumen Output</b>	380lm
<b>Light Source</b>	SMD LED 3000K
<b>Class</b>	II
<b>CRI</b>	>80
<b>Voltage (V/Hz)</b>	100V-240V/50-60Hz

## Magritte 450

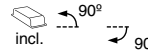

- 61084-110  Old Gold
- 61087-110  Matt Black
- 61081-110  Satin Nickel

<b>Material</b>	<b>Body</b> Aluminium+Steel
	<b>Diff</b> PMMA
<b>Power</b>	8W
<b>Lumen Output</b>	500lm
<b>Light Source</b>	SMD LED 3000K
<b>Class</b>	II
<b>CRI</b>	>80
<b>Voltage (V/Hz)</b>	110V/50-60Hz

## Magritte 600

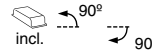

- 61082-110  Satin Nickel
- 61085-110  Old Gold
- 61088-110  Matt Black

<b>Material</b>	<b>Body</b> Aluminium+Steel
	<b>Diff</b> PMMA
<b>Power</b>	12W
<b>Lumen Output</b>	750lm
<b>Light Source</b>	SMD LED 3000K
<b>Class</b>	II
<b>CRI</b>	>80
<b>Voltage (V/Hz)</b>	110V/50-60Hz

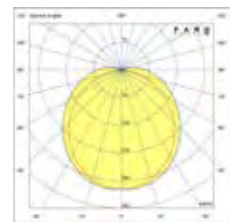
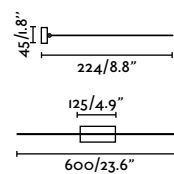
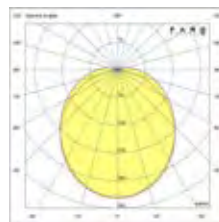
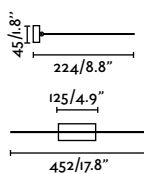
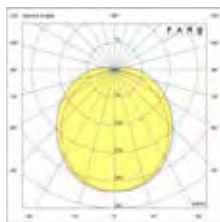
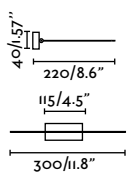

# Magritte

indoor

Surface



## Diula 2L



62986

● Satin Nickel

<b>Material</b>	<b>Body Steel</b>
	<b>Diff Opal Glass</b>
<b>Light Source</b>	2 E27 max. 15W
<b>Bulb incl.</b>	No
<b>Class</b>	I
<b>Voltage (V/Hz)</b>	100V-240V/50-60Hz

## Diula



62987

● Satin Nickel

<b>Material</b>	<b>Body Steel</b>
	<b>Diff Opal Glass</b>
<b>Light Source</b>	1 E27 max. 15W
<b>Bulb incl.</b>	No
<b>Class</b>	I
<b>Voltage (V/Hz)</b>	100V-240V/50-60Hz

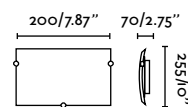
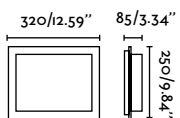

# Diula





**Perla**  
Àlex & Manel Llusçà

IP44



- 40085  Old Gold
- 40086  Chrome
- 40087  Bronze
- 40088  Black

<b>Material</b>	<b>Body Steel</b>
	<b>Diff Glass</b>
<b>Light Source</b>	1 G9 max. 6W
<b>Bulb incl.</b>	No
<b>Class</b>	II
<b>Voltage (V/Hz)</b>	100V-240V/50-60Hz

**Bianca**  
Àlex & Manel Llusçà

IP44



- 63510  Chrome

<b>Material</b>	<b>Body Aluminium</b>
	<b>Diff Glass</b>
<b>Light Source</b>	1 G9 max. 6W
<b>Bulb incl.</b>	No
<b>Class</b>	II
<b>Voltage (V/Hz)</b>	100V-240V/50-60Hz

**Brume**  
Àlex & Manel Llusçà

IP44



- 40076  Anthracite

<b>Material</b>	<b>Body Steel</b>
	<b>Diff Glass</b>
<b>Power</b>	3W
<b>Lumen Output</b>	200lm
<b>Light Source</b>	SMD LED 2700K
<b>Class</b>	II
<b>CRI</b>	>80
<b>Voltage (V/Hz)</b>	100V-240V/50-60Hz

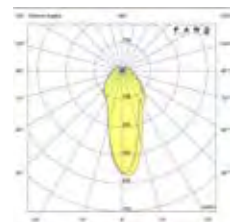
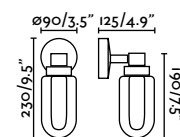
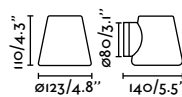

indoor

Surface

# Brume

Designed by Àlex & Manel Llusçà



Brume Ref. 40076  
Thanks to Upper Interiorismo



- 63504  Chrome  
63505  Satin Gold  
63506  Matt Black

<b>Material</b>	<b>Body</b> Aluminium <b>Diff</b> Opal Glass
<b>Light Source</b>	1 G9 max. 6W
<b>Bulb incl.</b>	No
<b>Class</b>	II
<b>Voltage (V/Hz)</b>	100V-240V/50-60Hz

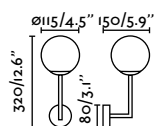

indoor

Surface





63503

Chrome

<b>Material</b>	<b>Body</b> Aluminium
	<b>Diff</b> Opal Glass
<b>Light Source</b>	1 G9 max. 6W
<b>Bulb incl.</b>	No
<b>Class</b>	II
<b>Voltage (V/Hz)</b>	100V-240V/50-60Hz

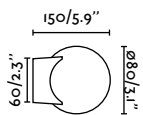



indoor

Surface



## Volga 310

IP44  incl.



63507

 Chrome

63512

 Matt Black

<b>Material</b>	<b>Body</b> Aluminium
	<b>Diff</b> PMMA
<b>Power</b>	5W
<b>Lumen Output</b>	350lm
<b>Light Source</b>	SMD LED 3000K
<b>Class</b>	II
<b>CRI</b>	>80
<b>Voltage (V/Hz)</b>	100V-240V/50-60Hz

## Volga 600

IP44  incl.



63508

 Chrome

63513

 Matt Black

<b>Material</b>	<b>Body</b> Aluminium
	<b>Diff</b> PMMA
<b>Power</b>	12W
<b>Lumen Output</b>	850lm
<b>Light Source</b>	SMD LED 3000K
<b>Class</b>	II
<b>CRI</b>	>80
<b>Voltage (V/Hz)</b>	100V-240V/50-60Hz

## Volga 900

IP44  incl.



63509

 Chrome

63514

 Matt Black

<b>Material</b>	<b>Body</b> Aluminium
	<b>Diff</b> PMMA
<b>Power</b>	18W
<b>Lumen Output</b>	1300lm
<b>Light Source</b>	SMD LED 3000K
<b>Class</b>	II
<b>CRI</b>	>80
<b>Voltage (V/Hz)</b>	100V-240V/50-60Hz

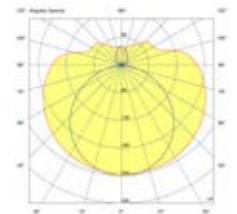
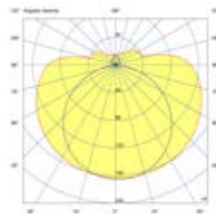
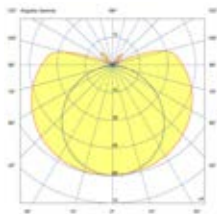
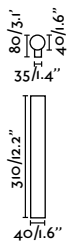

# Volga



Volga 310 Ref. 63512

## Nilo 600

IP44  incl.



- 63316  Matt Black
- 63318  Chrome

<b>Material</b>	<b>Body</b> Aluminium
	<b>Diff</b> Opal PMMA
<b>Power</b>	12W
<b>Lumen Output</b>	950lm
<b>Light Source</b>	SMD LED 3000K
<b>Class</b>	II
<b>CRI</b>	>80
<b>Voltage (V/Hz)</b>	100V-240V/50-60Hz



## Nilo 900

IP44  incl.



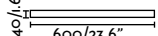

- 63317  Matt Black
- 63319  Chrome

<b>Material</b>	<b>Body</b> Aluminium
	<b>Diff</b> Opal PMMA
<b>Power</b>	18W
<b>Lumen Output</b>	1400lm
<b>Light Source</b>	SMD LED 3000K
<b>Class</b>	II
<b>CRI</b>	>80
<b>Voltage (V/Hz)</b>	100V-240V/50-60Hz

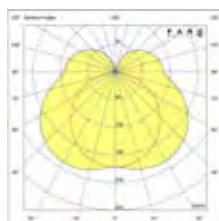
40°/1.6"  600/23.6"  60/2.3"

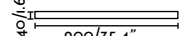

40°/1.6"  900/35.4"  60/2.3"

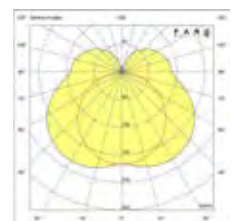

Nilo

indoor

Surface







102

# SPOT LIGHTS

## Stan LED

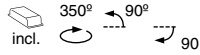

- 43726-110   Matt White + Matt Black
- 43727-110  Matt Black

<b>Material</b>	<b>Body</b> Aluminium
	<b>Diff</b> Transparent PC
<b>Power</b>	12W
<b>Lumen Output</b>	1200lm
<b>Light Source</b>	COB LED 2700K
<b>Class</b>	I
<b>CRI</b>	>90
<b>Voltage (V/Hz)</b>	110V/50-60Hz

## Stan

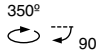

NEW



- 43722   Matt White + Matt Black
- 43723  Matt Black
- 43762   Satin Gold + Matt Black
- 43763   Terracotta + Matt Black

<b>Material</b>	<b>Body</b> Aluminium+ABS
<b>Light Source</b>	1 GU10 max. 5W
<b>Bulb incl.</b>	No
<b>Class</b>	I
<b>Voltage (V/Hz)</b>	100V-240V/50-60Hz

### Accessories



- 43728  Matt White
- 43729  Matt Gold

**Material** Body ABS



**Honey comb**  
43730

**Material** Body Aluminium



**Linear spread lens**  
43732

**Material** Body Glass



**Spread lens**  
43731

**Material** Body Glass

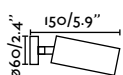
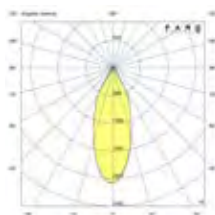

**Surface**  
418



**Ceiling**  
306



**Recessed**  
550



**Suspended**  
266



**Track**  
566



**Wall**  
480



# Stan

indoor

Spotlights



### Stan

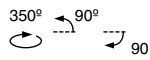

- 43740  Matt White
- 43741  Matt Black

<b>Material</b>	<b>Body Aluminium</b>
<b>Light Source</b>	1 GU10 max. 5W
<b>Bulb incl.</b>	No
<b>Class</b>	I
<b>Voltage (V/Hz)</b>	100V-240V/50-60Hz

### Stan 2L

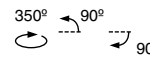

- 43742  Matt White
- 43743  Matt Black

<b>Material</b>	<b>Body Aluminium</b>
<b>Light Source</b>	2 GU10 max. 5W
<b>Bulb incl.</b>	No
<b>Class</b>	I
<b>Voltage (V/Hz)</b>	100V-240V/50-60Hz

### Stan 3L

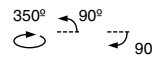

- 43744  Matt White
- 43745  Matt Black

<b>Material</b>	<b>Body Aluminium</b>
<b>Light Source</b>	3 GU10 max. 5W
<b>Bulb incl.</b>	No
<b>Class</b>	I
<b>Voltage (V/Hz)</b>	100V-240V/50-60Hz

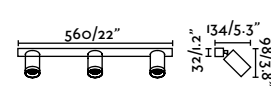
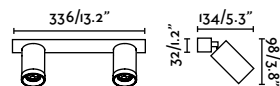
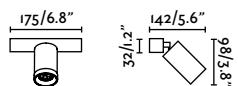





**Coco**  
Faro Lab

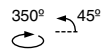

- 40660  Matt White
- 40661  Matt Black
- 40662   Matt Black + Green
- 40663   Matt Black + Terracotta

<b>Material</b>	<b>Body</b> ABS+Steel
<b>Light Source</b>	1 GU10 max. 8W
<b>Bulb incl.</b>	No
<b>Class</b>	I
<b>Voltage (V/Hz)</b>	100V-240V/50-60Hz

**Coco 2L**  
Faro Lab

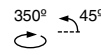

- 40664  Matt White
- 40665  Matt Black

<b>Material</b>	<b>Body</b> ABS+Steel
<b>Light Source</b>	2 GU10 max. 8W
<b>Bulb incl.</b>	No
<b>Class</b>	I
<b>Voltage (V/Hz)</b>	100V-240V/50-60Hz

**Coco 3L**  
Faro Lab

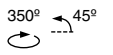

- 40666  Matt White
- 40667  Matt Black

<b>Material</b>	<b>Body</b> ABS+Steel
<b>Light Source</b>	3 GU10 max. 8W
<b>Bulb incl.</b>	No
<b>Class</b>	I
<b>Voltage (V/Hz)</b>	100V-240V/50-60Hz

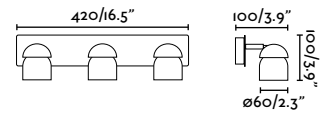
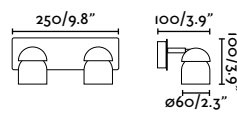
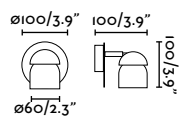

# Coco

Designed by Faro Lab



Coco Ref. 40663



Coco 2L Ref. 40665

**Stone**  
Àlex & Manel Llusçà

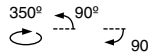

43500

● Grey + Matt Black

<b>Material</b>	<b>Body</b> Concrete+Steel
<b>Light Source</b>	1 GU10 max. 8W
<b>Bulb incl.</b>	No
<b>Class</b>	I
<b>Voltage (V/Hz)</b>	100V-240V/50-60Hz

**Stone 2L**  
Àlex & Manel Llusçà

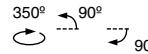

43501

● Grey + Matt Black

<b>Material</b>	<b>Body</b> Concrete+Steel
<b>Light Source</b>	2 GU10 max. 8W
<b>Bulb incl.</b>	No
<b>Class</b>	I
<b>Voltage (V/Hz)</b>	100V-240V/50-60Hz

**Stone 3L**  
Àlex & Manel Llusçà

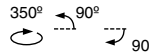

43502

● Grey + Matt Black

<b>Material</b>	<b>Body</b> Concrete+Steel
<b>Light Source</b>	3 GU10 max. 8W
<b>Bulb incl.</b>	No
<b>Class</b>	I
<b>Voltage (V/Hz)</b>	100V-240V/50-60Hz

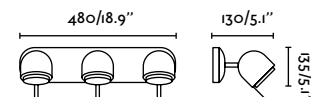
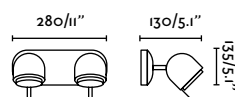
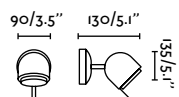

indoor

Spotlights

# Stone

Designed by Àlex & Manel Llusçà



Stone Ref. 43500

517



**Orleans**  
Nahtrng

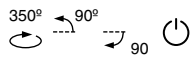

- 43520  Matt White
- 43521  Matt Black
- 43522  Chrome + Matt Black

<b>Material</b>	Body Steel
<b>Light Source</b>	1 GU10 max. 8W
<b>Bulb incl.</b>	No
<b>Class</b>	I
<b>Voltage (V/Hz)</b>	100V-240V/50-60Hz

**Orleans 2L**  
Nahtrng

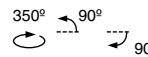

- 43525  Chrome + Matt Black

<b>Material</b>	Body Steel
<b>Light Source</b>	2 GU10 max. 8W
<b>Bulb incl.</b>	No
<b>Class</b>	I
<b>Voltage (V/Hz)</b>	100V-240V/50-60Hz

**Orleans 3L**  
Nahtrng

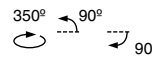

- 43527  Matt Black
- 43528  Chrome + Matt Black

<b>Material</b>	Body Steel
<b>Light Source</b>	3 GU10 max. 8W
<b>Bulb incl.</b>	No
<b>Class</b>	I
<b>Voltage (V/Hz)</b>	100V-240V/50-60Hz



Ceiling  
294

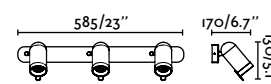
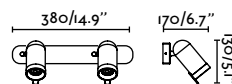
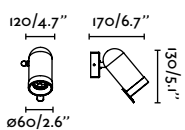

# Orleans

Designed by Nahrang



**Ring**  
Àlex & Manel Llusçà



- 40550  Matt White + Chrome
- 40551  Dark Grey + Chrome

<b>Material</b>	Body Steel
<b>Light Source</b>	1 GU10 max. 8W
<b>Bulb incl.</b>	No
<b>Class</b>	I
<b>Voltage (V/Hz)</b>	100V-240V/50-60Hz

**Link**  
Estudi Ribaudí

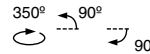

- 29873  Matt White
- 29874  Matt Black
- 29897  Bronze

<b>Material</b>	Body Steel
<b>Light Source</b>	1 GU10 max. 8W
<b>Bulb incl.</b>	No
<b>Class</b>	I
<b>Voltage (V/Hz)</b>	100V-240V/50-60Hz

**Link 2L**  
Estudi Ribaudí

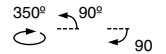

- 29875  Matt White
- 29876  Matt Black

<b>Material</b>	Body Steel
<b>Light Source</b>	2 GU10 max. 8W
<b>Bulb incl.</b>	No
<b>Class</b>	I
<b>Voltage (V/Hz)</b>	100V-240V/50-60Hz

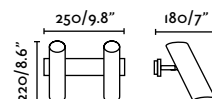
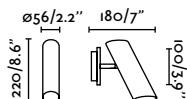
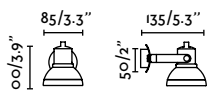
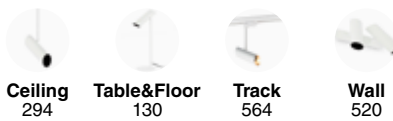

# Link

Designed by Estudi Ribaudí



205





**INDOOR**

**LIGHTING**

# RECESSED

**Domino**  
Aldanondoyfdez



63313 ● Matt White

<b>Material</b>	Body Plaster
	Diff Opal PMMA
<b>Power</b>	6W
<b>Lumen Output</b>	200lm
<b>Light Source</b>	SMD LED 2700K
<b>Class</b>	II
<b>CRI</b>	>=80
<b>Voltage (V/Hz)</b>	100V-240V/50-60Hz
<b>Cut out</b>	265x160

**Navi**



63481-110 ● White

<b>Material</b>	Body Plaster
<b>Power</b>	10W
<b>Lumen Output</b>	630lm
<b>Light Source</b>	SMD LED 3000K
<b>Class</b>	II
<b>CRI</b>	>80
<b>Voltage (V/Hz)</b>	110V/50-60Hz
<b>Cut out</b>	273x273

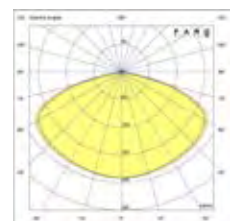
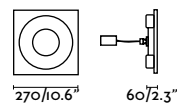
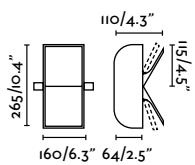
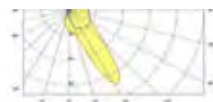

# Domino & Navi

This plaster luminaire is fully integrated into the wall.



Navi Ref. 63481-110

As it is made of plaster, it can be painted the same colour as the wall and integrate it into the space.



Domino Ref. 63313

## Neu

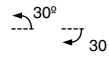

63286

● Matt White

<b>Material</b>	Body Plaster
<b>Light Source</b>	1 GU5.3 MR16 max. 8W
<b>Bulb incl.</b>	No
<b>Class</b>	III
<b>Voltage (V/Hz)</b>	100V-240V/50-60Hz
<b>Cut out</b>	ø160

## Nord

no incl.



63290

● Matt White

<b>Material</b>	Body Plaster
	Diff Opal PMMA
<b>Power</b>	18W
<b>Lumen Output</b>	1400lm
<b>Light Source</b>	SMD LED 3000K
<b>Class</b>	III
<b>CRI</b>	>80
<b>Cut out</b>	ø305

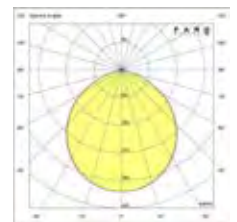
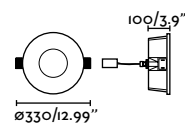
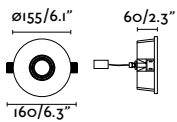

\*Drivers info pag. 1404-1405

# Nord

indoor

Recessed



Nord Ref. 63290

527



## Plas RCT

no incl. DIM

NEW



63491 ● White

<b>Material</b>	Body Plaster
<b>Power</b>	3W
<b>Lumen Output</b>	153 lm
<b>Light Source</b>	HIGH POWER LED 2700K
<b>Class</b>	III
<b>CRI</b>	>80
<b>Voltage (V/Hz)</b>	100V-240V/50-60Hz
<b>Cut out</b>	248x113

## Plas RCT

incl. DIM



63490 ● White

<b>Material</b>	Body Plaster
<b>Power</b>	3W
<b>Lumen Output</b>	200lm
<b>Light Source</b>	HIGH POWER LED 3000K
<b>Class</b>	II
<b>CRI</b>	>80
<b>Voltage (V/Hz)</b>	100V-240V/50-60Hz
<b>Cut out</b>	248x113

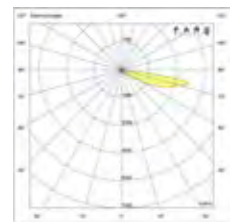
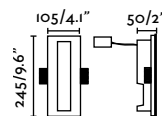
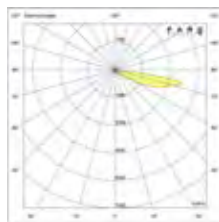
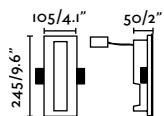

\*Drivers info pag. 1404-1405

indoor

Recessed

# Plas



Plas RCT Ref. 63490

Thanks to Lucía Buiza | Photo by Pablo Gómez-Ogando Rodríguez

## Plas oval

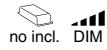

63281

● Matt White

<b>Material</b>	Body Plaster
<b>Power</b>	1W
<b>Lumen Output</b>	112lm
<b>Light Source</b>	HIGH POWER LED 3000K
<b>Class</b>	III
<b>CRI</b>	>80
<b>Cut out</b>	175x110

## Plas linear

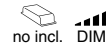

63282

● Matt White

<b>Material</b>	Body Plaster
<b>Power</b>	1W
<b>Lumen Output</b>	112lm
<b>Light Source</b>	HIGH POWER LED 3000K
<b>Class</b>	III
<b>CRI</b>	>80
<b>Cut out</b>	231x85

## Plas SQ

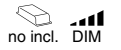

63283

● Matt White

<b>Material</b>	Body Plaster
<b>Power</b>	1W
<b>Lumen Output</b>	112lm
<b>Light Source</b>	HIGH POWER LED 3000K
<b>Class</b>	III
<b>CRI</b>	>80
<b>Cut out</b>	155x110

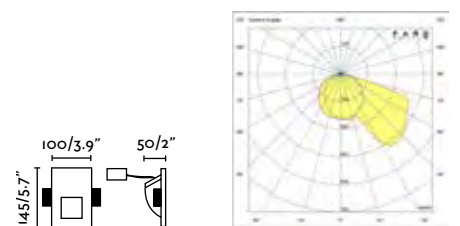
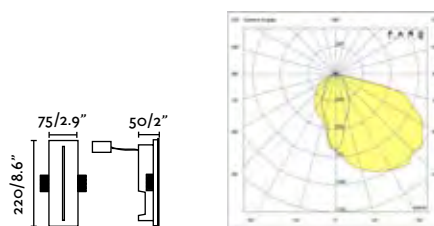
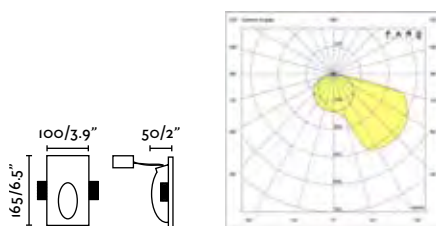

\*Drivers info pag. 1404-1405

indoor

Recessed



## Hyde R Orientable

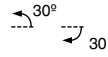

- 40118  Matt White
- 40119  Matt Black

<b>Material</b>	Body Steel
<b>Light Source</b>	1 GU10 max. 8W
<b>Bulb incl.</b>	No
<b>Voltage (V/Hz)</b>	100V-240V/50-60Hz
<b>Socket incl.</b>	No
<b>Recom. Socket</b>	43065
<b>Cut out</b>	ø83

## Hyde R

IP44



- 40114  Matt White
- 40115  Matt Black

<b>Material</b>	Body Steel
<b>Light Source</b>	1 GU10 max. 8W
<b>Bulb incl.</b>	No
<b>Voltage (V/Hz)</b>	100V-240V/50-60Hz
<b>Socket incl.</b>	No
<b>Recom. Socket</b>	43065
<b>Cut out</b>	ø83

## Hyde R Orientable Trimless

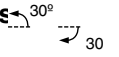

- 40110  Matt White
- 40111  Matt Black

<b>Material</b>	Body Steel
<b>Light Source</b>	1 GU10 max. 8W
<b>Bulb incl.</b>	No
<b>Voltage (V/Hz)</b>	100V-240V/50-60Hz
<b>Socket incl.</b>	No
<b>Recom. Socket</b>	43065
<b>Cut out</b>	ø83

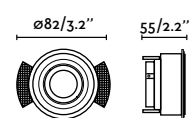
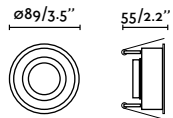
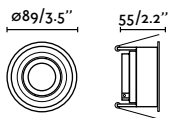



# Hyde

indoor

Recessed



Plus RCT Ref. 63490

Thanks to Limes Architetti | Photo by Angelo Talia

## Hyde SQ Orientable

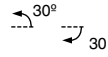

- 40120  Matt White
- 40121  Matt Black

<b>Material</b>	<b>Body Steel</b>
<b>Light Source</b>	1 GU10 max. 8W
<b>Bulb incl.</b>	No
<b>Voltage (V/Hz)</b>	100V-240V/50-60Hz
<b>Socket incl.</b>	No
<b>Recom. Socket</b>	43065
<b>Cut out</b>	83x83

## Hyde SQ

IP44



- 40116  Matt White
- 40117  Matt Black

<b>Material</b>	<b>Body Steel</b>
<b>Light Source</b>	1 GU10 max. 8W
<b>Bulb incl.</b>	No
<b>Voltage (V/Hz)</b>	100V-240V/50-60Hz
<b>Socket incl.</b>	No
<b>Recom. Socket</b>	43065
<b>Cut out</b>	83x83

## Hyde SQ Orientable Trimless

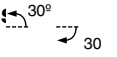

- 40112  Matt White
- 40113  Matt Black

<b>Material</b>	<b>Body Steel</b>
<b>Light Source</b>	1 GU10 max. 8W
<b>Bulb incl.</b>	No
<b>Voltage (V/Hz)</b>	100V-240V/50-60Hz
<b>Socket incl.</b>	No
<b>Recom. Socket</b>	43065
<b>Cut out</b>	102x93

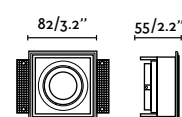
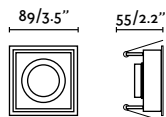
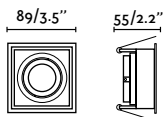



indoor

Recessed



## Hyde SQ Orientable 2L

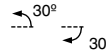

- 40126  Matt White
- 40127  Matt Black

<b>Material</b>	<b>Body Steel</b>
<b>Light Source</b>	2 GU10 max. 8W
<b>Bulb incl.</b>	No
<b>Voltage (V/Hz)</b>	100V-240V/50-60Hz
<b>Socket incl.</b>	No
<b>Recom. Socket</b>	43065
<b>Cut out</b>	83x165

## Hyde SQ 2L

IP44



- 40124  Matt White
- 40125  Matt Black

<b>Material</b>	<b>Body Steel</b>
<b>Light Source</b>	2 GU10 max. 8W
<b>Bulb incl.</b>	No
<b>Voltage (V/Hz)</b>	100V-240V/50-60Hz
<b>Socket incl.</b>	No
<b>Recom. Socket</b>	43065
<b>Cut out</b>	83x165

## Hyde SQ Orientable Trimless

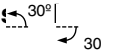

- 40122  Matt White
- 40123  Matt Black

<b>Material</b>	<b>Body Steel</b>
<b>Light Source</b>	2 GU10 max. 8W
<b>Bulb incl.</b>	No
<b>Voltage (V/Hz)</b>	100V-240V/50-60Hz
<b>Socket incl.</b>	No
<b>Recom. Socket</b>	43065
<b>Cut out</b>	182x93

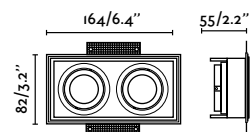
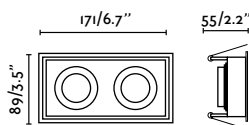
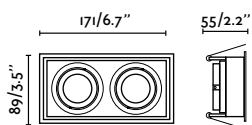



indoor

Recessed





## Radon SQ

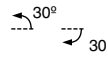

- 43396  Matt White
- 43406  Matt Black

<b>Material</b>	Body Aluminium
<b>Light Source</b>	1 GU10 max. 8W
<b>Bulb incl.</b>	No
<b>Voltage (V/Hz)</b>	100V-240V/50-60Hz
<b>Socket incl.</b>	No
<b>Recom. Socket</b>	43065
<b>Cut out</b>	ø80

## Radon RCT

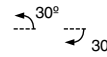

- 43397  Matt White
- 43407  Matt Black

<b>Material</b>	Body Aluminium
<b>Light Source</b>	2 GU10 max. 8W
<b>Bulb incl.</b>	No
<b>Voltage (V/Hz)</b>	100V-240V/50-60Hz
<b>Socket incl.</b>	No
<b>Recom. Socket</b>	43065
<b>Cut out</b>	80x170

## Radon R

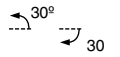

- 43398  Matt White
- 43408  Matt Black

<b>Material</b>	Body Aluminium
<b>Light Source</b>	1 GU10 max. 8W
<b>Bulb incl.</b>	No
<b>Voltage (V/Hz)</b>	100V-240V/50-60Hz
<b>Socket incl.</b>	No
<b>Recom. Socket</b>	43065
<b>Cut out</b>	ø80

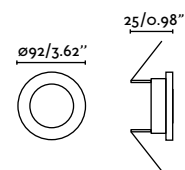
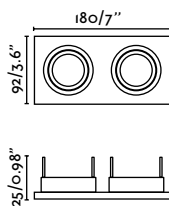
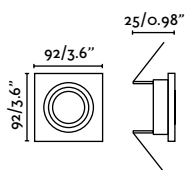

indoor

Recessed

# Radon



Radon R Ref. 43398

Thanks to RODES arquitectura&diseño | Photo by Germán Cabo

## Argon SQ

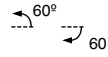

- 43402  Matt White
- 43412  Matt Black

<b>Material</b>	<b>Body Aluminium</b>
<b>Light Source</b>	1 GU10 max. 8W
<b>Bulb incl.</b>	No
<b>Voltage (V/Hz)</b>	100V-240V/50-60Hz
<b>Socket incl.</b>	No
<b>Recom. Socket</b>	43065
<b>Cut out</b>	100x100

## Argon RCT

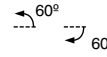

- 43403  Matt White
- 43413  Matt Black

<b>Material</b>	<b>Body Aluminium</b>
<b>Light Source</b>	2 GU10 max. 8W
<b>Bulb incl.</b>	No
<b>Voltage (V/Hz)</b>	100V-240V/50-60Hz
<b>Socket incl.</b>	No
<b>Recom. Socket</b>	43065
<b>Cut out</b>	220x102

## Argon R

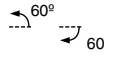

- 43401  Matt White
- 43411  Matt Black

<b>Material</b>	<b>Body Aluminium</b>
<b>Light Source</b>	1 GU10 max. 8W
<b>Bulb incl.</b>	No
<b>Voltage (V/Hz)</b>	100V-240V/50-60Hz
<b>Socket incl.</b>	No
<b>Recom. Socket</b>	43065
<b>Cut out</b>	ø100

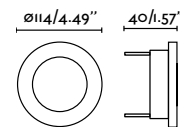
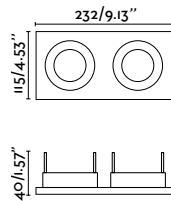
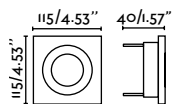

# Argon

indoor

Recessed



## Neon SQ



- 43400  Matt White  
 43410  Matt Black

<b>Material</b>	<b>Body Aluminium</b>
<b>Light Source</b>	1 GU10 max. 8W
<b>Bulb incl.</b>	No
<b>Voltage (V/Hz)</b>	100V-240V/50-60Hz
<b>Socket incl.</b>	No
<b>Recom. Socket</b>	43065
<b>Cut out</b>	70x70

## Neon R



- 43399  Matt White  
 43409  Matt Black

<b>Material</b>	<b>Body Aluminium</b>
<b>Light Source</b>	1 GU10 max. 8W
<b>Bulb incl.</b>	No
<b>Voltage (V/Hz)</b>	100V-240V/50-60Hz
<b>Socket incl.</b>	No
<b>Recom. Socket</b>	43065
<b>Cut out</b>	ø65

## Gas



- 43404  Matt White  
 43405  Matt Black

<b>Material</b>	<b>Body Aluminium</b>
<b>Light Source</b>	1 GU10 max. 8W
<b>Bulb incl.</b>	No
<b>Voltage (V/Hz)</b>	100V-240V/50-60Hz
<b>Socket incl.</b>	No
<b>Recom. Socket</b>	43065
<b>Cut out</b>	ø76

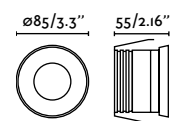
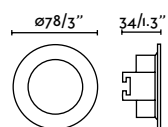
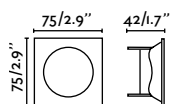



# Neon

indoor

Recessed



Neon R Ref. 43399

Thanks to Rez Estudio | Photo by Carla Capdevila

## Nais Orientable

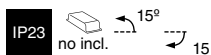

- 02111001 ● White
- 02111002 ● Black

<b>Material</b>	<b>Body</b> Aluminium+Steel
	<b>Diff</b> PMMA
<b>Power</b>	7W
<b>Lumen Output</b>	625lm
<b>Light Source</b>	COB LED 2700K
<b>Class</b>	III
<b>CRI</b>	>=90
<b>Beam angle</b>	15°
<b>Cut out</b>	ø76

## Nais

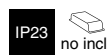

- 02121001 ● White
- 02121002 ● Black

<b>Material</b>	<b>Body</b> Aluminium+Steel
	<b>Diff</b> PMMA
<b>Power</b>	7W
<b>Lumen Output</b>	625lm
<b>Light Source</b>	COB LED 2700K
<b>Class</b>	III
<b>CRI</b>	>=90
<b>Beam angle</b>	15°
<b>Cut out</b>	ø60

## Koi

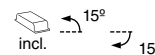

- 42921-110 ● Matt White

<b>Material</b>	<b>Body</b> PC
	<b>Diff</b> PC
<b>Power</b>	6W
<b>Lumen Output</b>	400lm
<b>Light Source</b>	SMD LED 3000K
<b>Class</b>	II
<b>CRI</b>	>80
<b>Voltage (V/Hz)</b>	110V/50-60Hz
<b>Cut out</b>	ø72

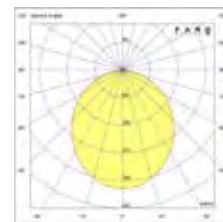
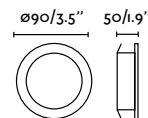
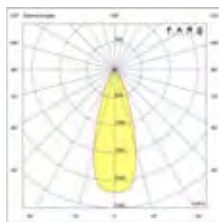
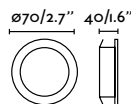
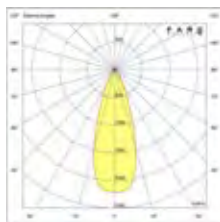
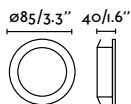

\*Drivers info pag. 1404-1405

\*Drivers info pag. 1404-1405

Nais

indoor

Recessed



# Click



- 43600  Matt White
- 43601  Matt Black

<b>Material</b>	<b>Body</b> Aluminium
	<b>Diff</b> Transparent PC
<b>Power</b>	3,2W
<b>Lumen Output</b>	252lm
<b>Light Source</b>	SMD LED 2700K
<b>Class</b>	II
<b>CRI</b>	85
<b>Voltage (V/Hz)</b>	100V-240V/50-60Hz
<b>Cut out</b>	80

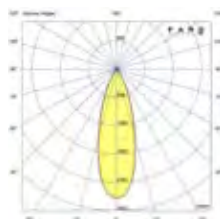
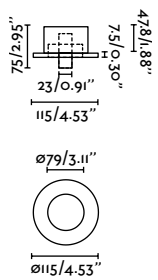

indoor

Recessed

Click



Click Ref. 43600

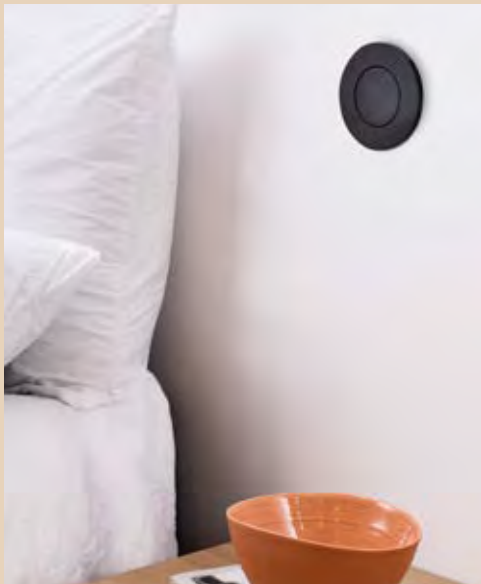

Click Ref. 43601



## Wet

IP44



02100801 ● Matt White

<b>Material</b>	<b>Body Steel</b>
	<b>Diff Transparent Glass</b>
<b>Light Source</b>	1 GU10 max. 8W
<b>Bulb incl.</b>	No
<b>Voltage (V/Hz)</b>	100V-240V/50-60Hz
<b>Cut out</b>	ø65



## Clear

IP65 no incl. DIM



02100301 ● Matt White

<b>Material</b>	<b>Body Aluminium</b>
	<b>Diff Glass</b>
<b>Power</b>	7W
<b>Lumen Output</b>	403lm
<b>Light Source</b>	COB LED 3000K
<b>Class</b>	III
<b>CRI</b>	>80
<b>Beam angle</b>	55°
<b>Cut out</b>	ø60

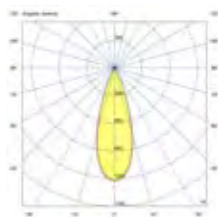
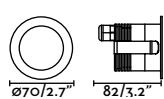

## Wabi

no incl. DIM



43900 ● Matt White

<b>Material</b>	<b>Body Aluminium</b>
	<b>Diff PC</b>
<b>Power</b>	10W
<b>Lumen Output</b>	600lm
<b>Light Source</b>	COB LED
<b>Dimmable K</b>	1800 - 3200K
<b>Class</b>	III
<b>CRI</b>	>=90
<b>Beam angle</b>	60°
<b>Cut out</b>	ø70

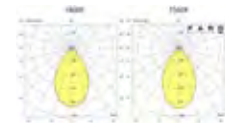
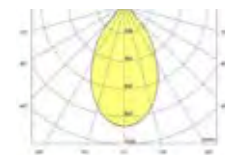
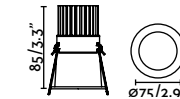

\*Drivers info pag. 1404-1405

\*Drivers info pag. 1404-1405

Clear

indoor

Recessed



## Stan recessed

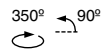

## Ebba



## Moist

IP44



- 43752 ● Matt White
- 43753 ● Matt Black
- 43761 ● Satin Gold

- 42919 ● Satin Nickel

- 02100901 ● Matt White

<b>Material</b>	<b>Body</b> Aluminium+ABS
<b>Light Source</b>	1 GU10 max. 5W
<b>Bulb incl.</b>	No
<b>Class</b>	I
<b>Voltage (V/Hz)</b>	100V-240V/50-60Hz
<b>Cut out</b>	ø50

<b>Material</b>	<b>Body</b> Aluminium
	<b>Diff</b> PMMA
<b>Power</b>	4W
<b>Lumen Output</b>	304lm
<b>Light Source</b>	SMD LED 3000K
<b>Class</b>	II
<b>CRI</b>	>80
<b>Voltage (V/Hz)</b>	100V-240V/50-60Hz
<b>Cut out</b>	ø63

<b>Material</b>	<b>Body</b> Steel
	<b>Diff</b> Transparent Glass
<b>Light Source</b>	1 GU10 max. 8W
<b>Bulb incl.</b>	No
<b>Class</b>	II
<b>Voltage (V/Hz)</b>	100V-240V/50-60Hz
<b>Cut out</b>	78x78

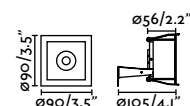
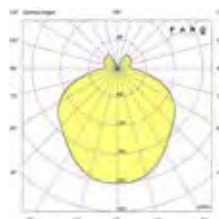
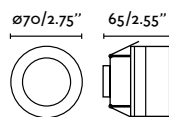
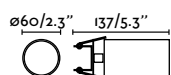

\*Accessories page 538

\*Drivers info pag. 1404-1405



# Stan



Stan recessed Ref. 43753

Thanks to David Labori Arquitectura | Photo by Doblecoco Studio

## Fox

no incl. DIM



- 02101001 ● Matt White
- 02101002 ● Matt Black

<b>Material</b>	<b>Body Aluminium</b>
	<b>Diff Transparent Glass</b>
<b>Power</b>	5W
<b>Lumen Output</b>	500lm
<b>Light Source</b>	COB LED 2700K
<b>Class</b>	III
<b>CRI</b>	>80
<b>Beam angle</b>	55°
<b>Cut out</b>	ø35

## Fox Trimless

no incl. DIM



- 02101101 ● Matt White
- 02101102 ● Matt Black

<b>Material</b>	<b>Body Aluminium</b>
	<b>Diff Transparent Glass</b>
<b>Power</b>	5W
<b>Lumen Output</b>	500lm
<b>Light Source</b>	COB LED 2700K
<b>Class</b>	III
<b>CRI</b>	>=90
<b>Beam angle</b>	55°
<b>Cut out</b>	ø45

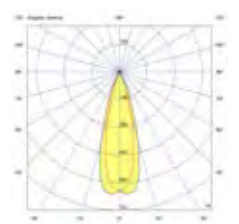
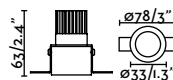
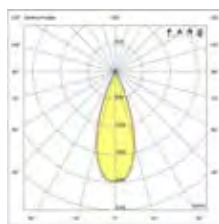
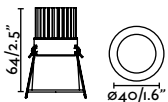

\*Drivers info pag. 1404-1405

\*Drivers info pag. 1404-1405



# Fox

indoor

Recessed



Fox Ref. 02101002  
Thanks to Anna Brotons & AB Interior Design | Photo by Estudio Ampersand

## Fox 50 Orientable

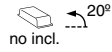

- 02101301 ● Matt White
- 02101302 ● Matt Black

<b>Material</b>	<b>Body Aluminium</b>
	<b>Diff Glass</b>
<b>Power</b>	5W
<b>Lumen Output</b>	500lm
<b>Light Source</b>	COB LED 2700K
<b>Class</b>	III
<b>CRI</b>	>80
<b>Beam angle</b>	15°
<b>Cut out</b>	ø45

## Fox 50

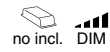

- 02101501 ● Matt White

<b>Material</b>	<b>Body Aluminium</b>
	<b>Diff Glass</b>
<b>Power</b>	7W
<b>Lumen Output</b>	535lm
<b>Light Source</b>	COB LED 2700K
<b>Class</b>	III
<b>CRI</b>	>80
<b>Beam angle</b>	15°
<b>Cut out</b>	ø40

## Fox 65



- 02101601 ● Matt White

<b>Material</b>	<b>Body Aluminium</b>
	<b>Diff Glass</b>
<b>Power</b>	10W
<b>Lumen Output</b>	680lm
<b>Light Source</b>	COB LED 2700K
<b>Class</b>	III
<b>CRI</b>	>80
<b>Beam angle</b>	15°
<b>Cut out</b>	ø55

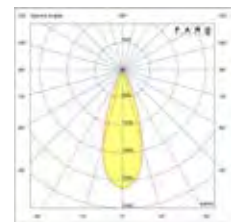
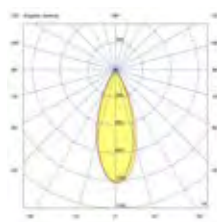
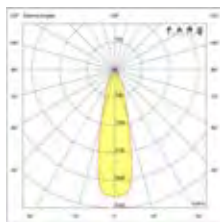
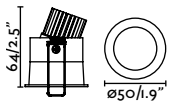

\*Drivers info pag. 1404-1405

\*Drivers info pag. 1404-1405

\*Drivers info pag. 1404-1405





## Fresh IP44

IP44



- 02200501  Matt White
- 02200502  Matt Black
- 02200503  Matt Gold

<b>Material</b>	<b>Body</b> Aluminium
	<b>Diff</b> Transparent Glass
<b>Light Source</b>	1 GU10 max. 8W
<b>Bulb incl.</b>	No
<b>Class</b>	II
<b>Voltage (V/Hz)</b>	100V-240V/50-60Hz
<b>Cut out</b>	ø83

## Fresh



- 02100501  Matt White
- 02100502  Matt Black
- 02100503  Matt Gold

<b>Material</b>	<b>Body</b> Aluminium
<b>Light Source</b>	1 GU10 max. 8W
<b>Bulb incl.</b>	No
<b>Class</b>	II
<b>Voltage (V/Hz)</b>	100V-240V/50-60Hz
<b>Cut out</b>	ø83

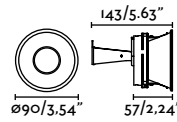
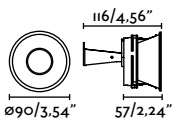

Fresh

indoor

Recessed



Fresh Ref. 02100502

Thanks to RODES arquitectura&diseño | Photo by Germán Cabo



## Fresh Trimless



- 02100701  Matt White
- 02100702  Matt Black

<b>Material</b>	Body Aluminium
<b>Light Source</b>	1 GU10 max. 8W
<b>Bulb incl.</b>	No
<b>Class</b>	II
<b>Voltage (V/Hz)</b>	100V-240V/50-60Hz
<b>Cut out</b>	ø90

## Fresh E27 Trimless



- 02300101  White

<b>Material</b>	Body Aluminium
<b>Light Source</b>	1 E27 max. 8W
<b>Bulb incl.</b>	No
<b>Class</b>	I
<b>Voltage (V/Hz)</b>	100V-240V/50-60Hz
<b>Cut out</b>	ø90

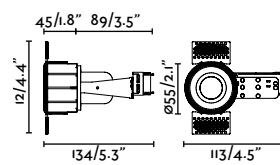
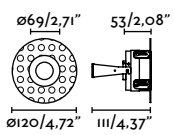

indoor

Recessed



## Fresh Wall Washer



- 02100601  Matt White
- 02100602  Matt Black
- 02100603  Matt Gold

<b>Material</b>	<b>Body Aluminium</b>
<b>Light Source</b>	1 GU10 max. 8W
<b>Bulb incl.</b>	No
<b>Class</b>	II
<b>Voltage (V/Hz)</b>	100V-240V/50-60Hz
<b>Cut out</b>	ø83

## Fresh IP65

IP65



- 02101401  Matt White
- 02101402  Matt Black

<b>Material</b>	<b>Body Aluminium</b>
	<b>Diff Transparent Glass</b>
<b>Light Source</b>	1 GU10 max. 8W
<b>Bulb incl.</b>	No
<b>Class</b>	I
<b>Voltage (V/Hz)</b>	100V-240V/50-60Hz
<b>Cut out</b>	ø83

## Fresh IP65 Trimless

IP65



- 02400101  Matt White
- 02400102  Matt Black

<b>Material</b>	<b>Body Aluminium</b>
	<b>Diff Transparent Glass</b>
<b>Light Source</b>	1 GU10 max. 8W
<b>Bulb incl.</b>	No
<b>Class</b>	I
<b>Voltage (V/Hz)</b>	100V-240V/50-60Hz
<b>Cut out</b>	ø83

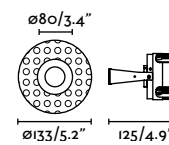
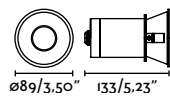
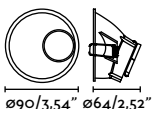

indoor

Recessed

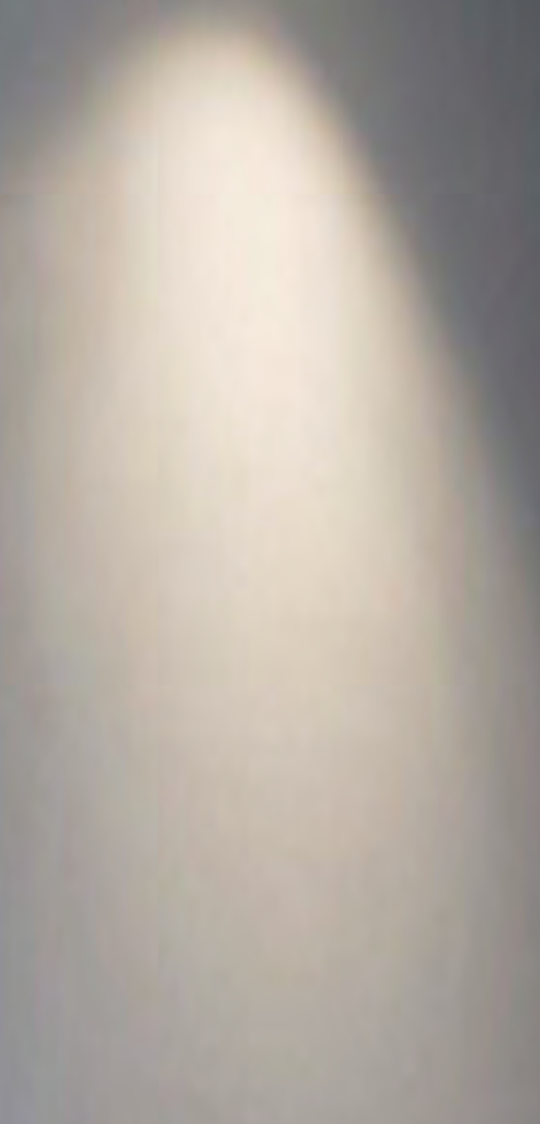





**INDOOR**

**LIGHTING**

# TRACK

**Link**  
Estudi Ribaudí

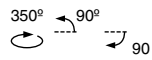

- 29871  Matt White
- 29872  Matt Black
- 29896  Bronze

<b>Material</b>	<b>Body Steel+ABS</b>
<b>Light Source</b>	1 GU10 max. 8W
<b>Bulb incl.</b>	No
<b>Class</b>	I
<b>Voltage (V/Hz)</b>	100V-240V/50-60Hz

**Plot**

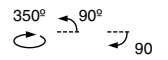

- 64202  Matt White
- 64203  Matt Black

<b>Material</b>	<b>Body Steel+ABS</b>
<b>Light Source</b>	1 GU10 max. 8W
<b>Bulb incl.</b>	No
<b>Class</b>	I
<b>Voltage (V/Hz)</b>	100V-240V/50-60Hz



**Ceiling**  
294



**Spot**  
520



**Table&Floor**  
130



**Wall**  
520

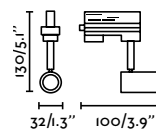
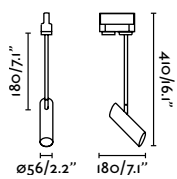

# Link

Designed by Estudi Ribaudí



Link Ref. 29872

Thanks to João Nuno Macedo, Ricardo Silva, Marta Machado | Photo by José Campos

## Stan LED

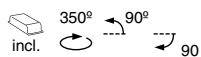

- 43725-110  Matt Black
- 43724-110  Matt White

<b>Material</b>	<b>Body</b> Aluminium
	<b>Diff</b> Transparent PC
<b>Power</b>	12W
<b>Lumen Output</b>	1200lm
<b>Light Source</b>	COB LED 2700K
<b>Class</b>	I
<b>CRI</b>	>80
<b>Voltage (V/Hz)</b>	110V/50-60Hz

## Stan

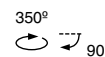

- 43720  Matt White
- 43721  Matt Black
- 43757  Satin Gold

<b>Material</b>	<b>Body</b> Aluminium+ABS
<b>Light Source</b>	1 GU10 max. 5W
<b>Bulb incl.</b>	No
<b>Class</b>	I
<b>Voltage (V/Hz)</b>	100V-240V/50-60Hz

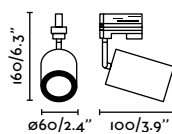
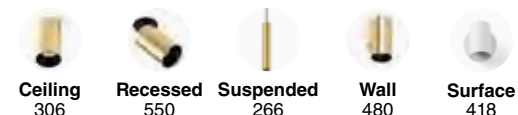
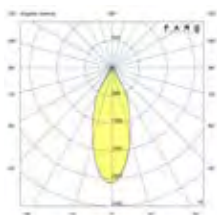
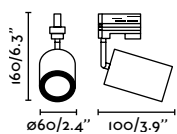

\*Accessories page 538

Stan

indoor

Track



Stan LED Ref. 43724-110

Track kit

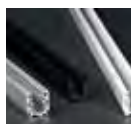

Surface track 1mts

- 64210A  White
- 64212A  Black
- 64214A  Grey

Material Body Aluminium

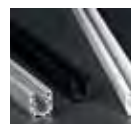

Surface track 2mts

- 64211A  White
- 64213A  Black
- 64215A  Grey

Material Body Aluminium





# OUTDOOR





**OUTDOOR**

**LIGHTING**

# **SYSTEMS**



Clap NEW  
Design Faro Lab











# Highlights

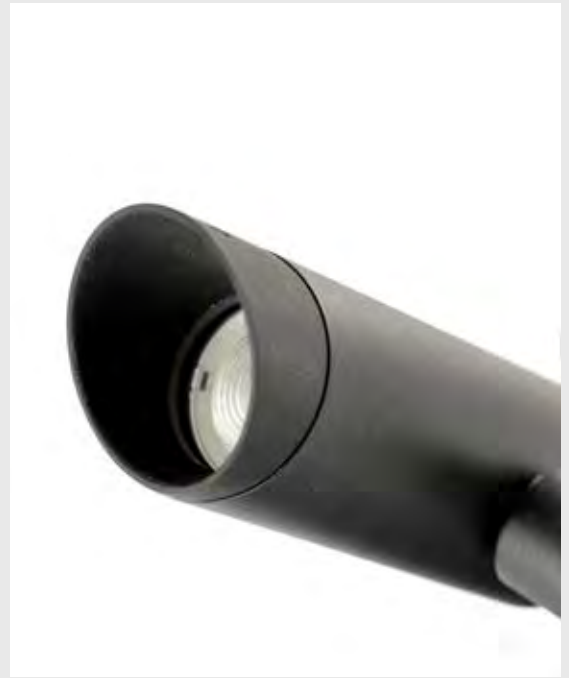

Anti-glare visor accessory ref. 75714-2



The design of the projector allows the light to be directed 360° on vertical and horizontal axes.

Move the product along the structure by adjusting/unadjusting the side screw.



Clip accessory included with each projector, allows the cable to be routed and fixed to the structure of the product.



The shade accessory allows for indirect lighting effects and a more decorative appearance. Lampshade  $\varnothing$ 310 ref. 75707-2 and lampshade  $\varnothing$ 400 ref. 75706-2





Clap  
6W

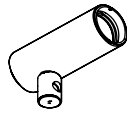

FINISH

○ White ● Black

COLOR TEMPERATURE

2700K CRI80

3000K CRI80

BEAM ANGLE

15°

24°

38°

ACCESSORIES



Spike 630



Spike 1030



Beacon 512



Beacon 1266



Wall/Projector



Lineal Wall/Ceiling

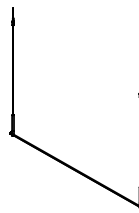

Suspended

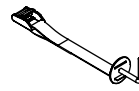

Tree projector

OPTIONAL ACCESSORIES



Indirect light plate  
ø310

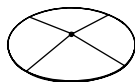

Indirect light plate  
ø400



Canopy



Visor

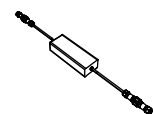

24V power supply

# Clap projector

Faro Lab

IP65  355°

<b>Material</b>	Body Aluminium
<b>Power</b>	6W
<b>Light Source</b>	COB LED
<b>Class</b>	III
<b>CRI</b>	>80
<b>Voltage (V/Hz)</b>	24V DC
<b>Cable</b>	2 MT

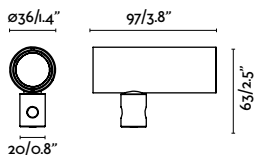

Family	Finish	Color T°	Beam Angle
75702- Clap Projector	2 Black	2 2700K	1 15°
	3 White	3 3000K	2 24°
			3 38°

Example: 75702-221 Clap projector black 2700K 15°

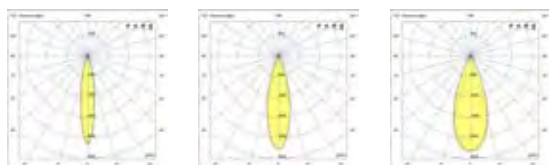

15°

24°

38°

Option	Color T°	CRI	Power	Lumen Output	Beam Angle
75702	2700K	80	6W	481lm / 553lm / 508lm	15° / 24° / 38°
75702	3000K			496lm / 570lm / 524lm	15° / 24° / 38°



# Accessories

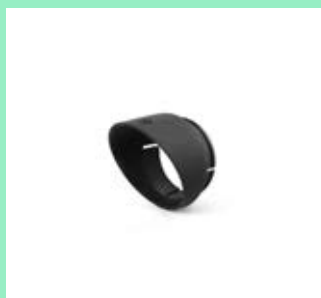

## Visor

75714-2

● Black

Material

Body Aluminium

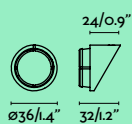

**Accesorio estaca 630 Clap**  
Faro Lab



**Accesorio estaca 1030 Clap**  
Faro Lab



75708-2 ● Black

**Material** Body Aluminium

\*Use with x2 projectors max.  
\*Drivers info pag. 554

**S Clap shade accessory**

75707-2 ● Black

**Material** Body Aluminium  
Shade Aluminium

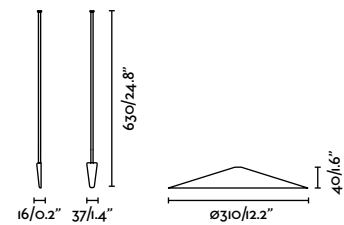

75709-2 ● Black

**Material** Body Aluminium+Stainless steel

\*Use with x3 projectors max.  
\*Drivers info pag. 554

**L Clap shade accessory**

75706-2 ● Black

**Material** Body Aluminium  
Shade Aluminium

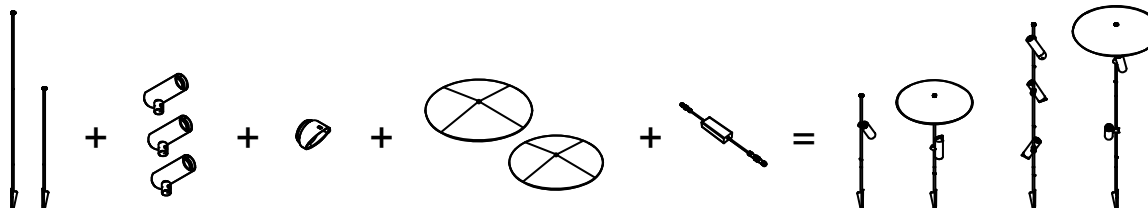
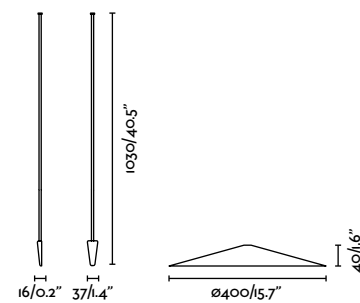

Choose your spike size

Choose the projector/s

Visor ref.75714-2 (Optional)

Shade ref. 75707-2 & ref. 75706-2 (Optional)

24V power supply

Your custom spike is ready!!





## Accesorio aplique/plafón lineal Clap

Faro Lab



- 75712-2 ● Black  
75712-1 ● White

**Material** Body Aluminium

\*Use with x3 projectors max.

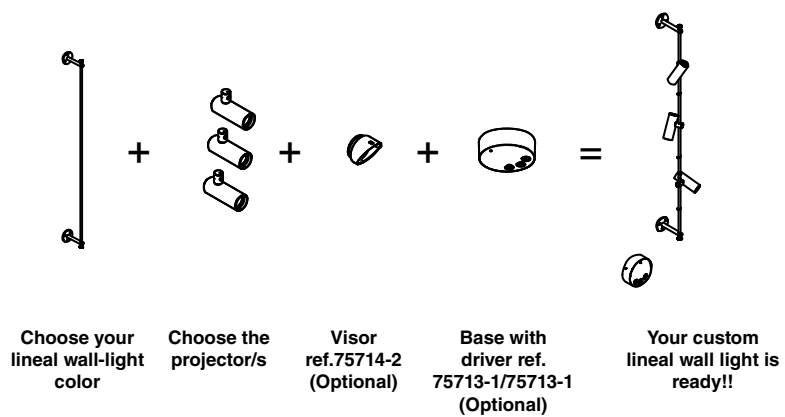
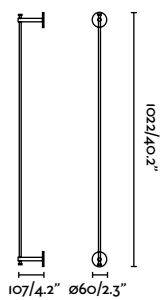





## Accesorio colgante Clap

Faro Lab



- 75711-2 ● Black
- 75711-1 ● White

---

**Material**      **Body Aluminium**

---

\*Use with x3 projectors max.

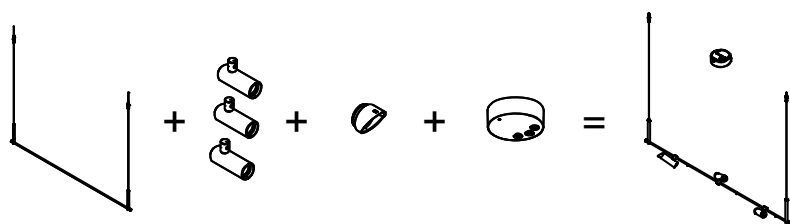
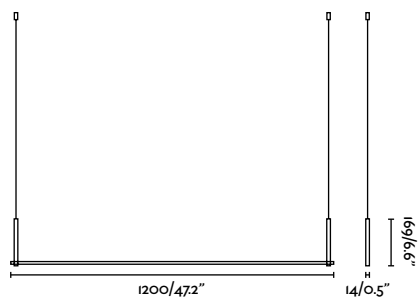

Choose your  
pendant color

Choose the  
projector/s

Visor  
ref.75714-2  
(Optional)

Base with  
driver ref.  
75713-1/75713-1  
(Optional)

Your custom pen-  
dant is ready!!





## Accesorio fijación árbol Clap

Faro Lab



75703-2

● Black

**Material** Body Aluminium

\*Use with 1 projector max.

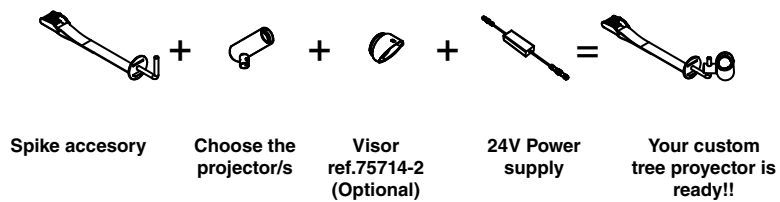
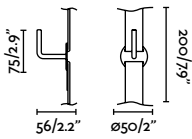





Candela 70790

**OUTDOOR**

**LIGHTING**

# **PORTABLES**



**Candela**  
Estudi Ribaudí

IP66 DIM

IN  
&OUT



70790 ● Terracotta

<b>Material</b>	<b>Body</b> Polystone <b>Diff</b> Opal PC
<b>Power</b>	3W
<b>Lumen Output</b>	290lm
<b>Light Source</b>	SMD LED 3000K
<b>Class</b>	III
<b>CRI</b>	>=80
<b>Battery incl.</b>	Yes 8 a 10h Charge Max. 6h Worktime

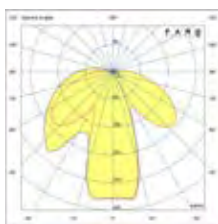
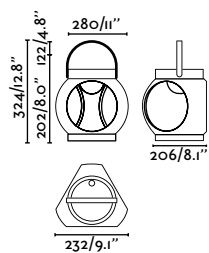



# Candela

**Design** Estudi Ribaudí

Candela is the essence of the Mediterranean made lamp. It is a rechargeable portable lamp that you can take anywhere.

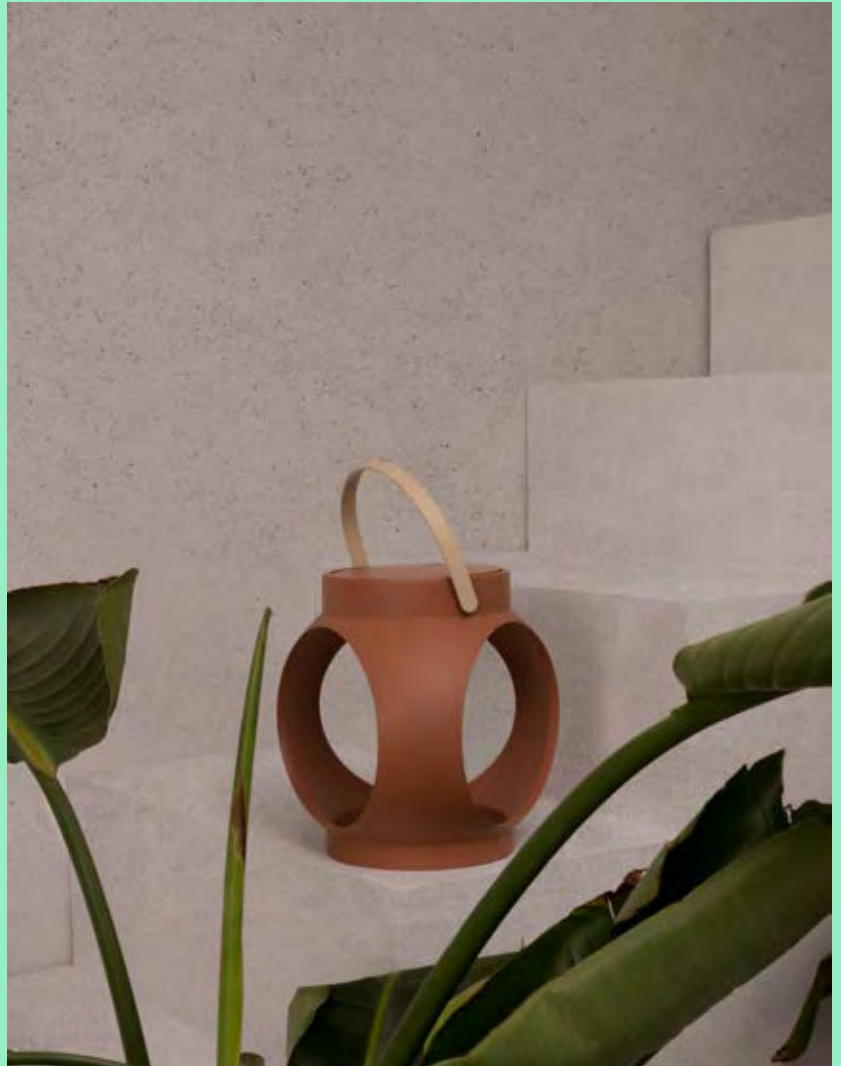

Touch switch

**Lampanot**  
Cristina Borràs



70496

● Matt White

<b>Material</b>	Body PEMD
	Diff Opal PEMD
<b>Power</b>	1W
<b>Lumen Output</b>	80lm
<b>Light Source</b>	SMD LED 3000K
<b>Class</b>	III
<b>CRI</b>	>80
<b>Battery incl.</b>	Yes
	2h Charge Max. 4h Worktime

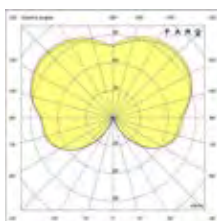
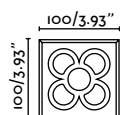

# Lampanot

**Design** Cristina Borràs



Portable both for interior and exterior that incorporates the symbol Panot, so characteristic in the tiles of the streets of the Eixample of Barcelona.

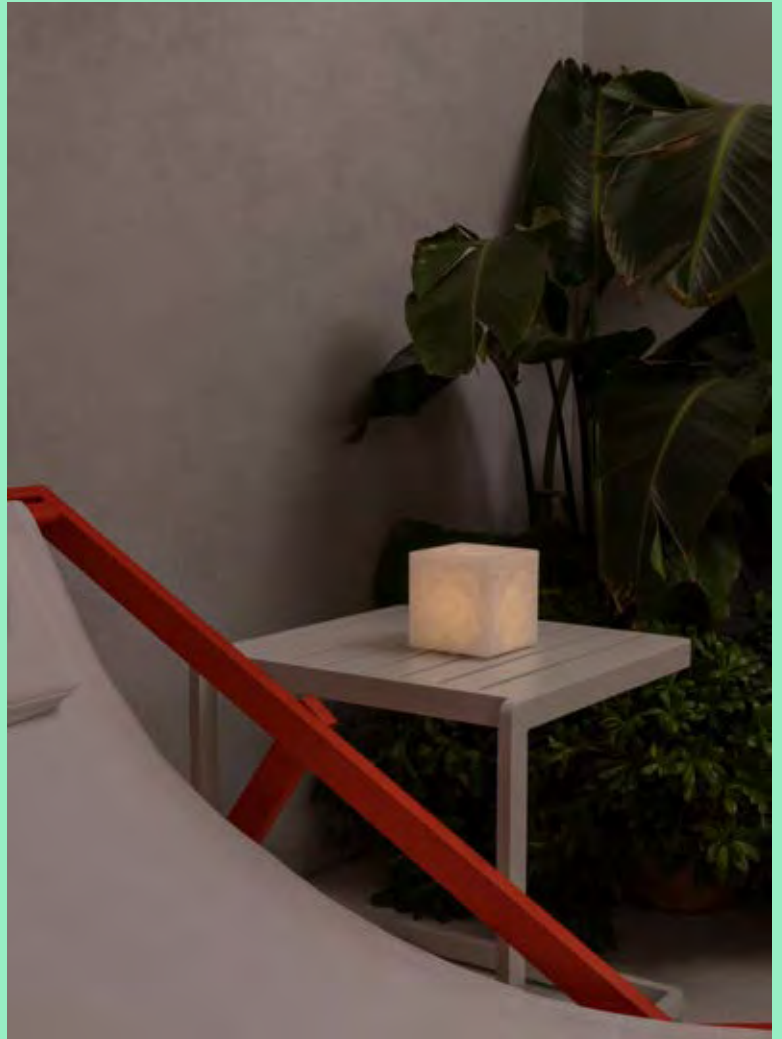

It is charged via USB and has three intensities.

## Kasp 300



IN & OUT



2700K



3000K



71912

● Black

<b>Material</b>	<b>Body Aluminium</b>
	<b>Diff Transparent PC</b>
<b>Power</b>	2,2W
<b>Lumen Output</b>	150lm
<b>Light Source</b>	SMD LED
<b>Dimmable K</b>	2700 - 3000K
<b>Class</b>	III
<b>CRI</b>	>80
<b>Battery incl.</b>	Yes
	20h Charge Max. 20h Worktime

### Wall accessory

71914 ● Black

**Material** **Body Aluminium**

## Kasp 500



IN & OUT



2700K



3000K



71913

● Black

<b>Material</b>	<b>Body Aluminium</b>
	<b>Diff Transparent PC</b>
<b>Power</b>	2,2W
<b>Lumen Output</b>	150lm
<b>Light Source</b>	SMD LED
<b>Dimmable K</b>	2700 - 3000K
<b>Class</b>	III
<b>CRI</b>	>80
<b>Battery incl.</b>	Yes
	20h Charge Max. 20h Worktime

### Wall accessory

71914 ● Black

**Material** **Body Aluminium**

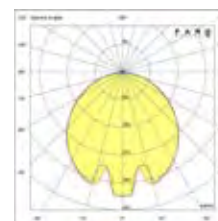
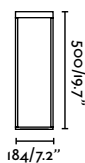
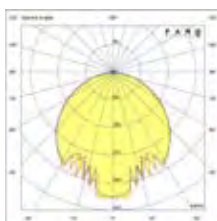
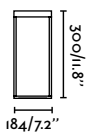



Kasp 500 71913



Hook available in accessory to use it as a wall lamp.



USB Charger



Portable solar lamp



## Argus

IP54 

IN & OUT



70784

● Dark Grey

<b>Material</b>	<b>Body</b> Aluminium
	<b>Diff</b> Transparent PMMA
<b>Power</b>	2W
<b>Lumen Output</b>	220lm
<b>Light Source</b>	SMD LED 3000K
<b>Class</b>	III
<b>CRI</b>	>80
<b>Battery incl.</b>	Yes
	5h Charge Max. 9h Worktime

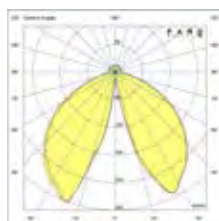
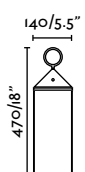

## Kerala

IP54   

IN & OUT



74454

● Dark Grey

<b>Material</b>	<b>Body</b> Aluminium
	<b>Diff</b> Transparent Glass
<b>Power</b>	5W
<b>Lumen Output</b>	400lm
<b>Light Source</b>	SMD LED 3000K
<b>Dimmable W</b>	100lm / 250lm / 400lm
<b>Class</b>	III
<b>CRI</b>	>80
<b>Battery incl.</b>	Yes
	8h Charge Max. 6h Worktime

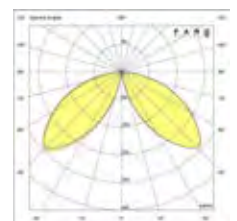
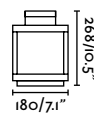



Argus 70784



Kerala 74454



100lm



250lm



400lm

## Toc 380



IN & OUT



- 70775 ● Matt White
- 70776 ● Matt Black
- 70777 ● Grey

<b>Material</b>	<b>Body</b> Aluminium <b>Diff</b> Opal PC
<b>Power</b>	2W
<b>Lumen Output</b>	180lm
<b>Light Source</b>	SMD LED 3000K
<b>Class</b>	III
<b>Battery incl.</b>	Yes 5h Charge Max. 9h Worktime

## Toc 1500



IN & OUT



- 70786 ● Matt White

<b>Material</b>	<b>Body</b> Aluminium <b>Diff</b> Opal PC
<b>Power</b>	5W
<b>Lumen Output</b>	468lm
<b>Light Source</b>	SMD LED 3000K
<b>Class</b>	III
<b>Battery incl.</b>	Yes 9h Charge Max. 9h Worktime

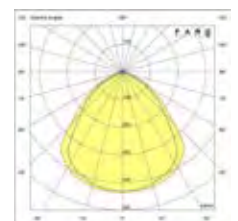
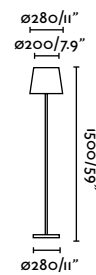
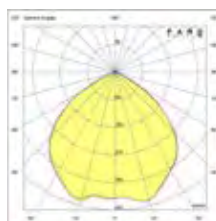
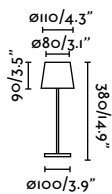



Toc 1500 70786



Touch lamp



**Saigon out R55**  
Nahtrang

IP44



71584-02 ●● Dark Grey + White

<b>Material</b>	<b>Body</b> Aluminium
	<b>Shade</b> PEMD
<b>Light Source</b>	1 E27 max. 15W
<b>Bulb incl.</b>	No
<b>Class</b>	II
<b>Cable</b>	3 MT



Floor  
612



Floor  
776

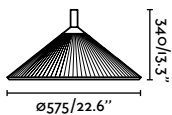



Saigon  
Design Nahtrang

outdoor

Portables



603

## Task

IP54 IK08 DIM



IN & OUT



70914

● Matt White

<b>Material</b>	<b>Body</b> Aluminium
	<b>Diff</b> Opal PC
<b>Power</b>	2W
<b>Lumen Output</b>	263lm
<b>Light Source</b>	SMD LED 3000K
<b>Dimmable W</b>	16lm / 103lm / 263lm
<b>Class</b>	III
<b>CRI</b>	>=80
<b>Voltage (V/Hz)</b>	5V DC
<b>Battery incl.</b>	Yes
	5h Charge Max. 6h Worktime



16lm



103lm



263lm

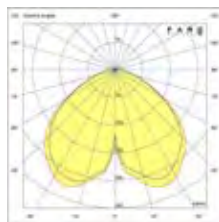

outdoor

Portables



Task 70914

605

## Balda 400



IN  
&OUT



70498

● Matt White

<b>Material</b>	<b>Body</b> PEMD
	<b>Diff</b> Opal PEMD
<b>Light Source</b>	1 E27 max. 15W
<b>Bulb incl.</b>	No
<b>Class</b>	II
<b>Cable</b>	1.8 MT

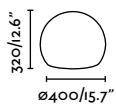

## Voila



IN  
&OUT



71565

●● Matt Black + Opal

<b>Material</b>	<b>Body</b> ABS
	<b>Diff</b> Opal PEMD
<b>Power</b>	2W
<b>Light Source</b>	RGB LED 3000K
<b>Class</b>	III
<b>Voltage (V/Hz)</b>	5V DC
<b>Battery incl.</b>	Yes
	10h Charge Max. 7h Worktime

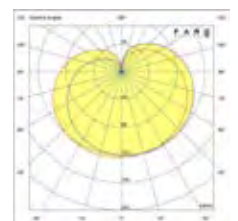



outdoor

Portables



Voila 71565

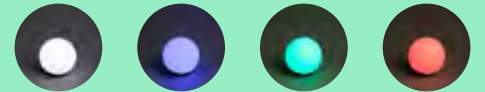

Balda 400 70498







# FLOOR

# Saigon

**Design** Nahtrang

It is characterized by simplicity and pure forms.

The shade is made of UV-resistant polyester cord that lets the light pass through creating a beautiful light effect.

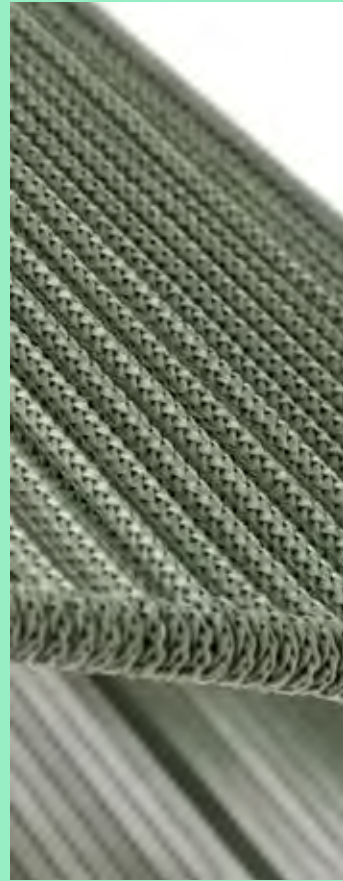

Saigon out 1200 C70 71575-13

outdoor

Floor



Saigon out C100 71569-12

Saigon out 1200  
W70 71575-07



**Saigon out C100**  
Nahtrang

IP44

NEW MATERIAL



- 71569-10  Dark Grey + Beige
- 71569-12  Dark Grey + Green
- 71569-14  Dark Grey + Ochre

<b>Material</b>	<b>Body</b> Aluminium+Concrete
	<b>Diff</b> Opal PEMD
	<b>Shade</b> PP
<b>Light Source</b>	1 E27 max. 15W
<b>Bulb incl.</b>	No
<b>Class</b>	II
<b>Cable</b>	2 MT

**Saigon out 1950 C70**  
Nahtrang

IP44

NEW MATERIAL



- 71569-09  Dark Grey + Beige
- 71569-11  Dark Grey + Green
- 71569-13  Dark Grey + Ochre

<b>Material</b>	<b>Body</b> Aluminium
	<b>Diff</b> Opal PEMD
	<b>Shade</b> PP
<b>Light Source</b>	1 E27 max. 15W
<b>Bulb incl.</b>	No
<b>Class</b>	II
<b>Cable</b>	2 MT

**Saigon out 1200 C70**  
Nahtrang

IP44

NEW MATERIAL



- 71575-09  Dark Grey + Beige
- 71575-11  Dark Grey + Green
- 71575-13  Dark Grey + Ochre

<b>Material</b>	<b>Body</b> Aluminium
	<b>Diff</b> Opal PEMD
	<b>Shade</b> PP
<b>Light Source</b>	1 E27 max. 15W
<b>Bulb incl.</b>	No
<b>Class</b>	II
<b>Cable</b>	2 MT



Ceiling  
802

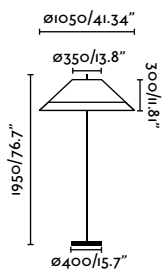

Floor  
772



Ceiling  
798



Ceiling  
802

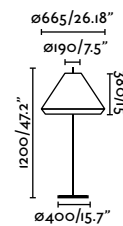
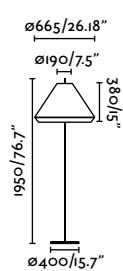



outdoor

Floor



Saigon out C100 71569-10

613



**Saigon out W100**  
Nahtrang

IP44



71569-08 ●● Dark Grey + Brown

**Saigon out 1950 W70**  
Nahtrang

IP44



71569-07 ●● Dark Grey + Brown

**Saigon out 1200 W70**  
Nahtrang

IP44



71575-07 ●● Dark Grey + Brown

<b>Material</b>	<b>Body</b> Aluminium+Concrete
	<b>Diff</b> Opal PEMD
	<b>Shade</b> Synthetic wicker
<b>Light Source</b>	1 E27 max. 15W
<b>Bulb incl.</b>	No
<b>Class</b>	II
<b>Cable</b>	2 MT

<b>Material</b>	<b>Body</b> Aluminium
	<b>Diff</b> Opal PEMD
	<b>Shade</b> Synthetic wicker
<b>Light Source</b>	1 E27 max. 15W
<b>Bulb incl.</b>	No
<b>Class</b>	II
<b>Cable</b>	2 MT

<b>Material</b>	<b>Body</b> Aluminium
	<b>Diff</b> Opal PEMD
	<b>Shade</b> Synthetic wicker
<b>Light Source</b>	1 E27 max. 15W
<b>Bulb incl.</b>	No
<b>Class</b>	II
<b>Cable</b>	2 MT

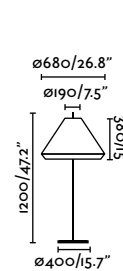
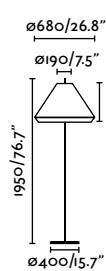
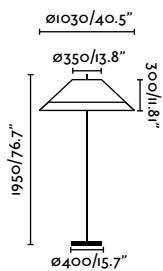
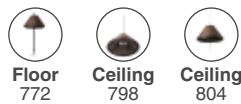







**Saigon out 1950 T70**  
Nahtrang

IP44



- 71569-05  Dark Grey + Cream
- 71569-06  Dark Grey + Brown

<b>Material</b>	<b>Body</b> Aluminium
	<b>Diff</b> Opal PEMD
	<b>Shade</b> Textilene
<b>Light Source</b>	1 E27 max. 15W
<b>Bulb incl.</b>	No
<b>Class</b>	II
<b>Cable</b>	2 MT

**Saigon out 1200 T70**  
Nahtrang

IP44



- 71575-05  Dark Grey + Cream
- 71575-06  Dark Grey + Brown

<b>Material</b>	<b>Body</b> Aluminium
	<b>Diff</b> Opal PEMD
	<b>Shade</b> Textilene
<b>Light Source</b>	1 E27 max. 15W
<b>Bulb incl.</b>	No
<b>Class</b>	II
<b>Cable</b>	2 MT



**Floor**  
772



**Suspended**  
798



**Ceiling**  
804

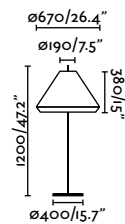
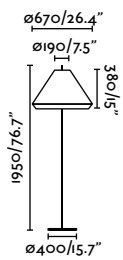



outdoor

Floor



Saigon out 1200 T70 71575-05

617



**Saigon out 2000 R55**  
Nahtrang

IP44



71569-01 ● Dark Grey + White

**Saigon out 1150 R55**  
Nahtrang

IP44



71575-01 ● Dark Grey + White

**Saigon out 500 R55**  
Nahtrang

IP44



71576-01 ● Dark Grey + White

<b>Material</b>	<b>Body</b> Aluminium
	<b>Diff</b> Opal PEMD
	<b>Shade</b> PEMD
<b>Light Source</b>	1 E27 max. 15W
<b>Bulb incl.</b>	No
<b>Class</b>	II
<b>Cable</b>	2 MT

<b>Material</b>	<b>Body</b> Aluminium
	<b>Diff</b> Opal PEMD
	<b>Shade</b> PEMD
<b>Light Source</b>	1 E27 max. 15W
<b>Bulb incl.</b>	No
<b>Class</b>	II
<b>Cable</b>	2 MT

<b>Material</b>	<b>Body</b> Aluminium
	<b>Diff</b> Opal PEMD
	<b>Shade</b> PEMD
<b>Light Source</b>	1 E27 max. 15W
<b>Bulb incl.</b>	No
<b>Class</b>	II
<b>Cable</b>	2 MT

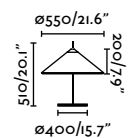
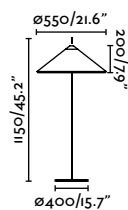
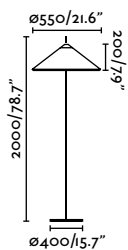
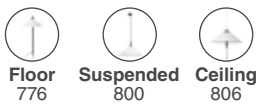

outdoor

Floor



Saigon out 1150 R55 71575-01

**Saigon out 2100 R45**  
Nahrang

IP44



71569-04 ● Dark Grey + White

**Saigon out 1300 R45**  
Nahrang

IP44



71575-04 ● Dark Grey + White

**Saigon out 670 R45**  
Nahrang

IP44



71576-04 ● Dark Grey + White

<b>Material</b>	<b>Body</b> Aluminium
	<b>Diff</b> Opal PEMD
	<b>Shade</b> PEMD
<b>Light Source</b>	1 E27 max. 15W
<b>Bulb incl.</b>	No
<b>Class</b>	II
<b>Cable</b>	2 MT

<b>Material</b>	<b>Body</b> Aluminium
	<b>Diff</b> Opal PEMD
	<b>Shade</b> PEMD
<b>Light Source</b>	1 E27 max. 15W
<b>Bulb incl.</b>	No
<b>Class</b>	II
<b>Cable</b>	2 MT

<b>Material</b>	<b>Body</b> Aluminium
	<b>Diff</b> Opal PEMD
	<b>Shade</b> PEMD
<b>Light Source</b>	1 E27 max. 15W
<b>Bulb incl.</b>	No
<b>Class</b>	II
<b>Cable</b>	2 MT

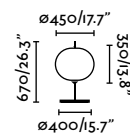
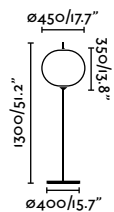
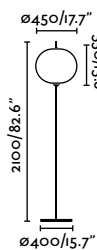
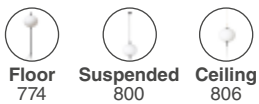



outdoor

Floor



Saigon out 2100 R45 71569-04

621

**Akane**  
Pepe Laudet

IP44



- 71262  Matt Black + Green  
71263  Matt Black + Beige

<b>Material</b>	<b>Body Steel</b>
	<b>Shade PP</b>
<b>Light Source</b>	E27 max. 12W
<b>Bulb incl.</b>	No
<b>Class</b>	II
<b>Cable</b>	5 MT

\*Only for glass LED bulbs, models A60, ST64, G95 and G125

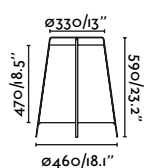



# Akane

**Design** Pepe Llaudet

Akane is inspired by the traditional street lamps of the east. The purity of their forms and choice of materials are key to them prevailing over time.



**Cadaques**  
Faro Lab

IP44  incl.

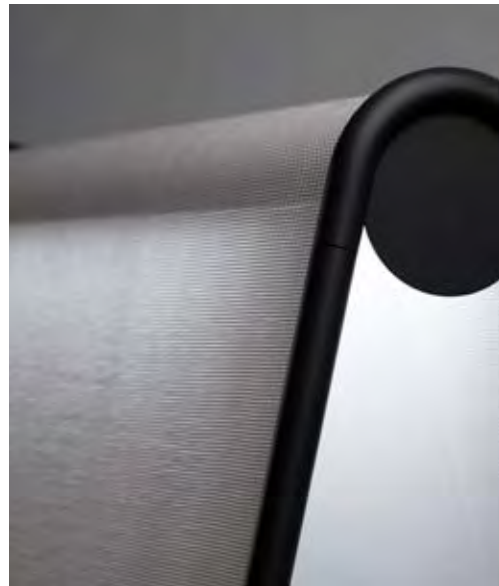

- 71242  Dark Grey + Beige
- 71243  Dark Grey + Blue

<b>Material</b>	<b>Body</b> Aluminium
	<b>Diff</b> Opal PC
	<b>Shade</b> Textilene
<b>Power</b>	18W
<b>Lumen Output</b>	500lm
<b>Light Source</b>	SMD LED 2700K
<b>Class</b>	II
<b>CRI</b>	>80
<b>Voltage (V/Hz)</b>	100V-240V/50-60Hz
<b>Cable</b>	3 MT



Floor fixing accessory included

**2.5mts. cable extension accessory**

71244

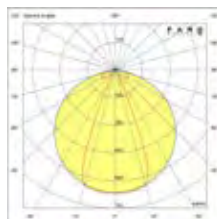
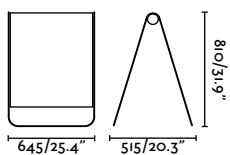



outdoor

Floor

# Cadaques

Design Faro Lab

Cadaqués evokes the enjoyment of outdoor spaces, taking us to the warmest months of the year.



Cadaques 71243

625

**Versus**  
Pepe Llaudet

IP44

**Versus structure S**  
Pepe Llaudet

**Versus structure L**  
Pepe Llaudet



74423 ● Matt White



74422 ● Black



74424 ● Black

<b>Material</b>	<b>Body</b> PEMD <b>Diff</b> Matt White
<b>Light Source</b>	1 E27 max. 15W
<b>Bulb incl.</b>	No
<b>Class</b>	II
<b>Cable</b>	3 MT

<b>Material</b>	<b>Body</b> Steel
-----------------	-------------------

<b>Material</b>	<b>Body</b> Steel
-----------------	-------------------

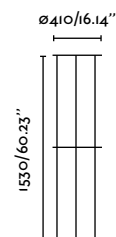
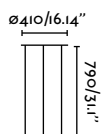
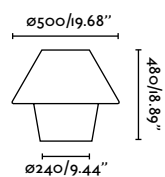



# Versus

**Design** Pepe Llaudet



Versus 74423 + Structure S 74422

Versus is the ideal choice not only for its design but also for its high resistance to outdoor environmental conditions.



Versus 74423



**Brot 900**  
Yembarastudio

IP65  incl.



71253 ● Black

<b>Material</b>	<b>Body</b> Aluminium <b>Diff</b> Opal Glass
<b>Power</b>	2x6W
<b>Lumen Output</b>	2x290lm
<b>Light Source</b>	SMD LED 2700K
<b>Class</b>	I
<b>CRI</b>	>80
<b>Voltage (V/Hz)</b>	100V-240V/50-60Hz
<b>Beam angle</b>	80°

**Brot 1800**  
Yembarastudio

IP65  incl.



71254 ● Black

<b>Material</b>	<b>Body</b> Aluminium <b>Diff</b> Opal Glass
<b>Power</b>	3x6W
<b>Lumen Output</b>	3x290lm
<b>Light Source</b>	SMD LED 2700K
<b>Class</b>	I
<b>CRI</b>	>80
<b>Voltage (V/Hz)</b>	100V-240V/50-60Hz
<b>Beam angle</b>	80°

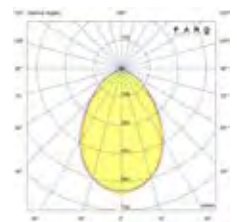
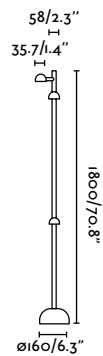
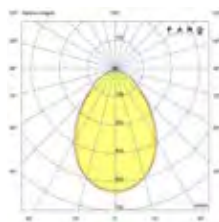
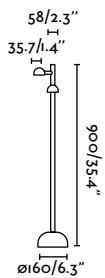

outdoor

Floor



Brot 1800 71254



Brot 900 71253

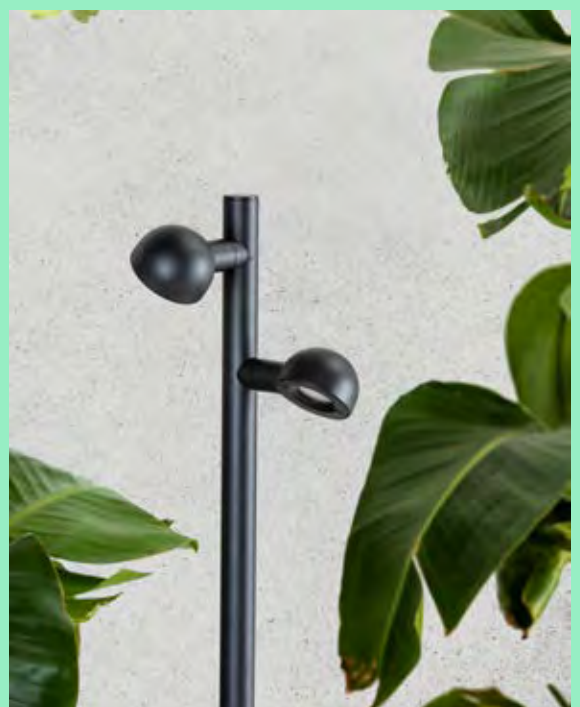

**Brot 900 portable**  
Yembarastudio

IP65  incl.



71256 ● Black

<b>Material</b>	<b>Body</b> Aluminium <b>Diff</b> Opal Glass
<b>Power</b>	2x6W
<b>Lumen Output</b>	2x290lm
<b>Light Source</b>	SMD LED 2700K
<b>Class</b>	I
<b>CRI</b>	>80
<b>Voltage (V/Hz)</b>	100V-240V/50-60Hz
<b>Cable</b>	1.8 MT

**Brot 1800 portable**  
Yembarastudio

IP65  incl.



71257 ● Black

<b>Material</b>	<b>Body</b> Aluminium <b>Diff</b> Opal Glass
<b>Power</b>	3x6W
<b>Lumen Output</b>	3x290lm
<b>Light Source</b>	SMD LED 2700K
<b>Class</b>	I
<b>CRI</b>	>80
<b>Voltage (V/Hz)</b>	100V-240V/50-60Hz
<b>Cable</b>	1.8 MT

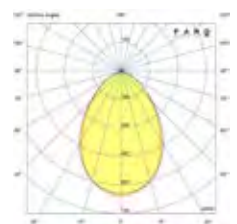
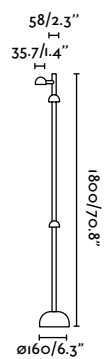
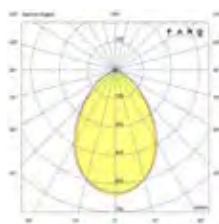
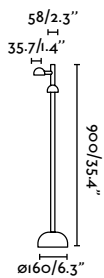



The high version (71257) includes a spike to install it in the lawn.

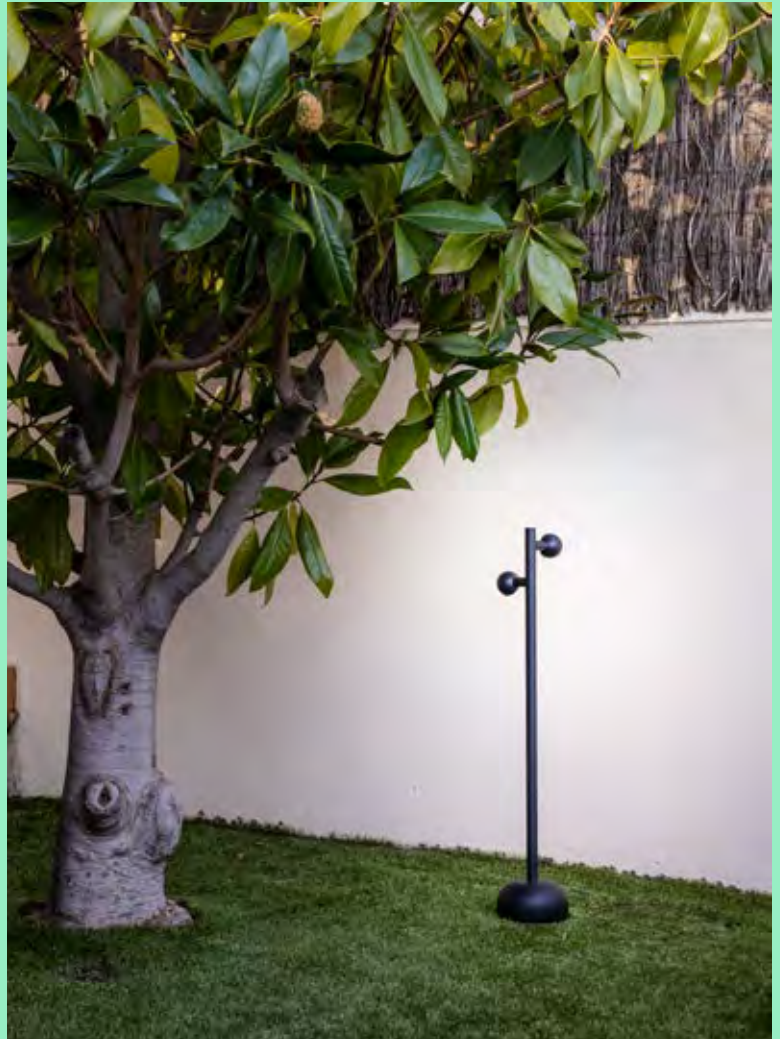

Brot 900 portable 71256



Its minimalist stainless steel structure in the shape of a semicircular arch raises generating elegant and minimalist scenographic spaces.

Available in two heights so that the most original compositions can be created.







**Cuca 650 24V**  
Faro Lab

IP65 IK06 no incl.

24V DC



75558 ● Black

<b>Material</b>	<b>Body</b> Stainless steel
	<b>Diff</b> Opal Glass
<b>Power</b>	3W
<b>Lumen Output</b>	154lm
<b>Light Source</b>	COB LED 2700K
<b>Class</b>	III
<b>CRI</b>	>90
<b>Voltage (V/Hz)</b>	24V DC
<b>Cable</b>	0.5 MT

\*Drivers info pag. 554



Floor  
768

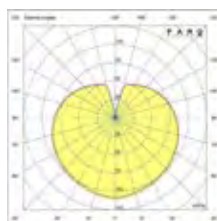
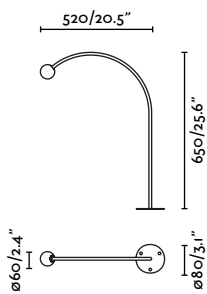

**Cuca 1193 24V**  
Faro Lab

IP65 IK06 no incl.

24V DC



75559 ● Black

<b>Material</b>	<b>Body</b> Stainless steel
	<b>Diff</b> Opal Glass
<b>Power</b>	3W
<b>Lumen Output</b>	154lm
<b>Light Source</b>	COB LED 2700K
<b>Class</b>	III
<b>CRI</b>	>90
<b>Voltage (V/Hz)</b>	24V DC
<b>Cable</b>	0.5 MT

\*Drivers info pag. 554



Floor  
768

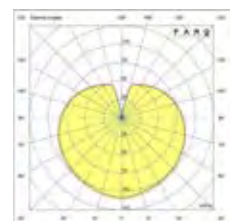
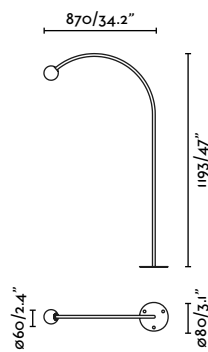





Cuca 1193 24V 75559



# Totem

Design Roger Vancells



Totem 611 75552



Totem 285 75551

Its simple, rounded lines form a compact, brutalist-inspired form that seeks to emphasize the expressive nature of its material, giving prominence to the natural concrete from which it is constructed.



reddot winner 2023







**Totem 285**  
Roger Vancells

IP55 IK06 incl. SEA SIDE SUITABLE IP68 CONNECTOR



- 75550-110 2700K ● Grey Cement
- 75551-110 3000K ● Grey Cement

<b>Material</b>	Body Concrete
<b>Power</b>	6,5W
<b>Lumen Output</b>	307lm [2700K] 370lm [3000K]
<b>Light Source</b>	SMD LED
<b>Class</b>	II
<b>CRI</b>	>=80
<b>Voltage (V/Hz)</b>	110V/50-60Hz

**Totem 611**  
Roger Vancells

IP55 IK06 incl. SEA SIDE SUITABLE IP68 CONNECTOR



- 75552-110 2700K ● Grey Cement
- 75553-110 3000K ● Grey Cement

<b>Material</b>	Body Concrete
<b>Power</b>	6,5W
<b>Lumen Output</b>	307lm [2700K] 370lm [3000K]
<b>Light Source</b>	SMD LED
<b>Class</b>	II
<b>CRI</b>	>=80
<b>Voltage (V/Hz)</b>	110V/50-60Hz

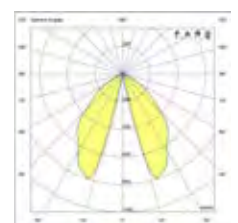
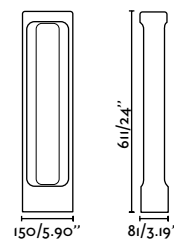
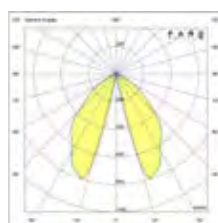
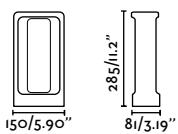







**Balic**  
Yembarastudio

IP65 IK06 incl.



70295-110 ● Black

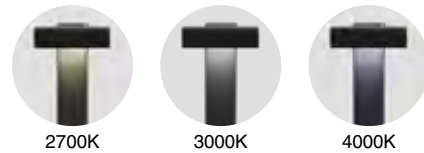

Chose fixture's color temperature by pressing CCT changeable button during the installation.

<b>Material</b>	<b>Body Aluminium</b>
	<b>Diff Glass</b>
<b>Power</b>	8W
<b>Lumen Output</b>	813/870/896lm
<b>Light Source</b>	SMD LED 2700K-3000K-4000K
<b>Class</b>	I
<b>CRI</b>	>=80
<b>Voltage (V/Hz)</b>	110V/50-60Hz

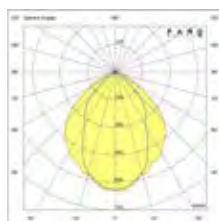
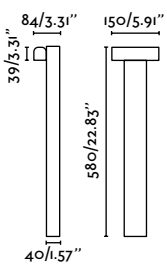



# Balic

Design Yembarastudio

Balic is a beacon with a discreet and functional design, made of die-cast aluminium and available in three colour temperature options.





**Lotus 350**  
Estudi Ribaudí

IP65 IK08 incl.



71224 ● Dark Grey

<b>Material</b>	<b>Body</b> Aluminium
	<b>Diff</b> Opal PC
<b>Power</b>	18W
<b>Lumen Output</b>	1120lm
<b>Light Source</b>	SMD LED 3000K
<b>Class</b>	I
<b>CRI</b>	>80
<b>Voltage (V/Hz)</b>	100V-240V/50-60Hz

**Lotus 650**  
Estudi Ribaudí

IP65 IK08 incl.



71225 ● Dark Grey

<b>Material</b>	<b>Body</b> Aluminium
	<b>Diff</b> Opal PC
<b>Power</b>	18W
<b>Lumen Output</b>	1120lm
<b>Light Source</b>	SMD LED 3000K
<b>Class</b>	I
<b>CRI</b>	>80
<b>Voltage (V/Hz)</b>	100V-240V/50-60Hz

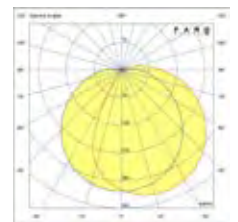
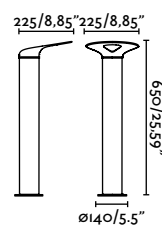
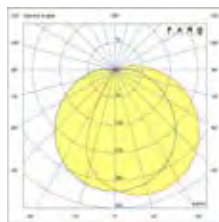
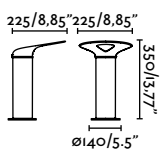



# Lotus

**Design** Estudi Ribaudí



Lotus 350 71224

Inspired by the lotus flower, this outdoor collection is made of aluminum which gives it greater robustness and durability.



**Block 350**  
Àlex & Manel Llusçà

IP65 IK06 SEA SIDE SUITABLE



74141 ● Grey Cement

<b>Material</b>	<b>Body Concrete</b>
	<b>Diff Opal Glass</b>
<b>Light Source</b>	1 E27 max. 15W
<b>Bulb incl.</b>	No
<b>Class</b>	I

**Block 700**  
Àlex & Manel Llusçà

IP65 IK06 SEA SIDE SUITABLE



74142 ● Grey Cement

<b>Material</b>	<b>Body Concrete</b>
	<b>Diff Opal Glass</b>
<b>Light Source</b>	1 E27 max. 15W
<b>Bulb incl.</b>	No
<b>Class</b>	I

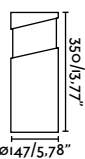

# Block

**Design** Àlex & Manel Llusçà



Its opal diffuser avoids glare.

Block will surprise you. Not only because it emits light in its 360 degrees but also because of the material in which it is made: concrete



## Cast 300

IP65 IK06 incl.



74155-110 ● Dark Grey

<b>Material</b>	<b>Body</b> Concrete
	<b>Diff</b> Opal PC
<b>Power</b>	10W
<b>Lumen Output</b>	550lm
<b>Light Source</b>	SMD LED 3000K
<b>Class</b>	I
<b>CRI</b>	>80
<b>Voltage (V/Hz)</b>	110V/50-60Hz

## Cast 500

IP65 IK06 incl.



74156-110 ● Dark Grey

<b>Material</b>	<b>Body</b> Concrete
	<b>Diff</b> Opal PC
<b>Power</b>	10W
<b>Lumen Output</b>	550lm
<b>Light Source</b>	SMD LED 3000K
<b>Class</b>	I
<b>CRI</b>	>80
<b>Voltage (V/Hz)</b>	110V/50-60Hz

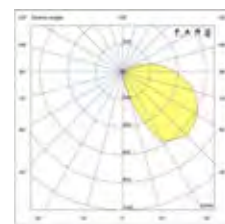
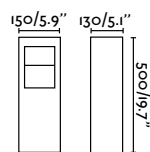
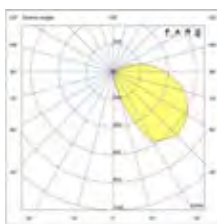
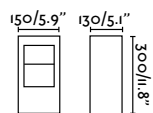



outdoor

Floor





**Twist 300**  
Estudi Ribaudí

IP65  incl.



71286 ● Dark Grey

<b>Material</b>	<b>Body</b> Aluminium <b>Diff</b> Opal PC
<b>Power</b>	10W
<b>Lumen Output</b>	500lm
<b>Light Source</b>	SMD LED 3000K
<b>Class</b>	I
<b>CRI</b>	>80
<b>Voltage (V/Hz)</b>	100V-240V/50-60Hz

**Twist 500**  
Estudi Ribaudí

IP65  incl.



71287 ● Dark Grey

<b>Material</b>	<b>Body</b> Aluminium <b>Diff</b> Opal PC
<b>Power</b>	10W
<b>Lumen Output</b>	500lm
<b>Light Source</b>	SMD LED 3000K
<b>Class</b>	I
<b>CRI</b>	>80
<b>Voltage (V/Hz)</b>	100V-240V/50-60Hz

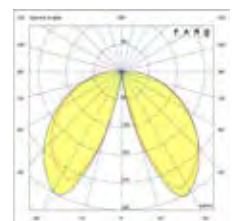
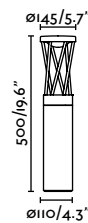
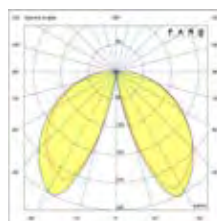
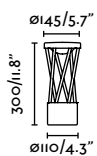

# Twist

Design Estudi Ribaudí



Twist 500 71287

It is original, fresh and fun and creates an effect of lights and shadows on the surfaces where it is located.



Twist 300 71286

**Tram 630**  
Estudi Ribaudí

IP65



75531

● Dark Grey

<b>Material</b>	<b>Body</b> Aluminium
	<b>Diff</b> Opal PMMA
<b>Light Source</b>	1 E27 max. 15W
<b>Bulb incl.</b>	No
<b>Class</b>	I



Wall  
842

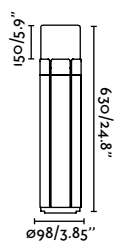

outdoor

Floor



Tram 630 75531

651

**Datna 300**  
Àlex & Manel Llusçà

IP44



74441

● ● Dark Grey + Opal

<b>Material</b>	<b>Body Aluminium</b>
	<b>Diff Opal PC</b>
<b>Light Source</b>	1 E27 max. 15W
<b>Bulb incl.</b>	No
<b>Class</b>	I

**Datna 600**  
Àlex & Manel Llusçà

IP44 IK05



74442

● ● Dark Grey + Opal

<b>Material</b>	<b>Body Aluminium</b>
	<b>Diff Opal PC</b>
<b>Light Source</b>	1 E27 max. 15W
<b>Bulb incl.</b>	No
<b>Class</b>	I



Wall  
842

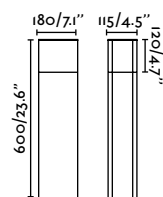
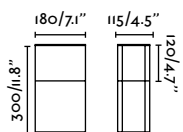



# Datna

**Design** Àlex & Manel Llusçà

Seeking integration with the urban landscape and new architecture, this collection of minimalist design is perfect to give a touch of diffuse light in gardens.



## Kila 400

IP65



- 71746  Dark Grey + Transparent
- 71747  Dark Grey + Smoked
- 71748   Dark Grey + Amber

<b>Material</b>	<b>Body</b> Aluminium
	<b>Diff</b> Transparent Glass
<b>Light Source</b>	1 E27 max. 15W
<b>Bulb incl.</b>	No
<b>Class</b>	I

## Kila 700

IP65



- 71749  Dark Grey + Transparent
- 71750  Dark Grey + Smoked
- 71751   Dark Grey + Amber

<b>Material</b>	<b>Body</b> Aluminium
	<b>Diff</b> Transparent Glass
<b>Light Source</b>	1 E27 max. 15W
<b>Bulb incl.</b>	No
<b>Class</b>	I



Ceiling  
824



Wall  
850

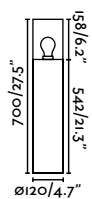
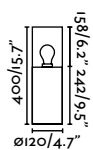



Kila 700 71750



Kila 400 71746



### Plim 1

IP65 IK08 incl.



71299 ● Dark Grey

<b>Material</b>	<b>Body Aluminium</b>
	<b>Diff Transparent PC</b>
<b>Power</b>	10W
<b>Lumen Output</b>	508lm
<b>Light Source</b>	SMD LED 3000K
<b>Class</b>	I
<b>CRI</b>	>80
<b>Voltage (V/Hz)</b>	100V-240V/50-60Hz

### Plim 2

IP65 IK08 incl.



71300 ● Dark Grey

<b>Material</b>	<b>Body Aluminium</b>
	<b>Diff Opal PC</b>
<b>Power</b>	10W
<b>Lumen Output</b>	400lm
<b>Light Source</b>	SMD LED 3000K
<b>Class</b>	I
<b>CRI</b>	>80
<b>Voltage (V/Hz)</b>	100V-240V/50-60Hz

### Plim 3

IP65 IK08 incl.



71301 ● Dark Grey

<b>Material</b>	<b>Body Aluminium</b>
	<b>Diff Transparent PC</b>
<b>Power</b>	10W
<b>Lumen Output</b>	478lm
<b>Light Source</b>	SMD LED 3000K
<b>Class</b>	I
<b>CRI</b>	>80
<b>Voltage (V/Hz)</b>	100V-240V/50-60Hz

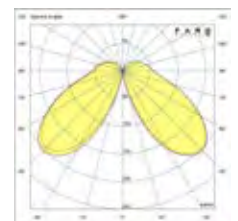
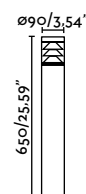
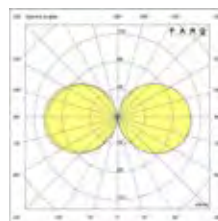
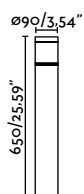
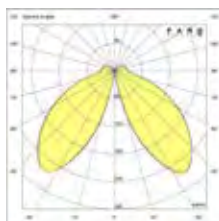
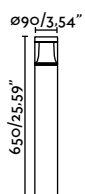

outdoor

Floor



Plim 3 71301



## Giza 265

IP54 IK05 incl.



70767

● Dark Grey

<b>Material</b>	<b>Body</b> Aluminium <b>Diff</b> Opal PC
<b>Power</b>	15W
<b>Lumen Output</b>	500lm
<b>Light Source</b>	COB LED 3000K
<b>Class</b>	I
<b>CRI</b>	>80
<b>Voltage (V/Hz)</b>	100V-240V/50-60Hz

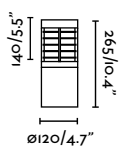

## Giza 650

IP54 IK05 incl.



70768

● Dark Grey

<b>Material</b>	<b>Body</b> Aluminium <b>Diff</b> Opal PC
<b>Power</b>	15W
<b>Lumen Output</b>	500lm
<b>Light Source</b>	COB LED 3000K
<b>Class</b>	I
<b>CRI</b>	>80
<b>Voltage (V/Hz)</b>	100V-240V/50-60Hz

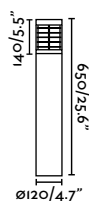



Giza 265 70767

Wilma 270

IP44



74997

● Dark Grey

Wilma 340

IP44



75001

● Dark Grey

Wilma 820

IP44



75003

● Dark Grey

<b>Material</b>	<b>Body Aluminium</b>
	<b>Diff Opal PC</b>
<b>Light Source</b>	1 E27 max. 15W
<b>Bulb incl.</b>	No
<b>Class</b>	I

<b>Material</b>	<b>Body Aluminium</b>
	<b>Diff Opal PC</b>
<b>Light Source</b>	1 E27 max. 15W
<b>Bulb incl.</b>	No
<b>Class</b>	I

<b>Material</b>	<b>Body Aluminium</b>
	<b>Diff Opal PC</b>
<b>Light Source</b>	1 E27 max. 15W
<b>Bulb incl.</b>	No
<b>Class</b>	I



Wall  
852

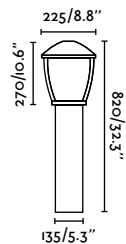
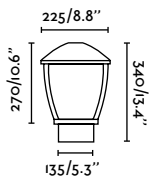
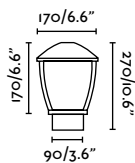

outdoor

Floor



Wilma 820 75003



Wilma 270 74997

## Beret 500

IP54 IK04 incl.



75522-110 ● Dark Grey

<b>Material</b>	<b>Body</b> Aluminium
	<b>Diff</b> Opal PMMA
<b>Power</b>	8W
<b>Lumen Output</b>	350lm
<b>Light Source</b>	SMD LED 4000K
<b>Class</b>	I
<b>CRI</b>	>80
<b>Voltage (V/Hz)</b>	110V/50-60Hz

## Beret 900

IP54 IK04 incl.



75523-110 ● Dark Grey

<b>Material</b>	<b>Body</b> Aluminium
	<b>Diff</b> Opal PMMA
<b>Power</b>	8W
<b>Lumen Output</b>	350lm
<b>Light Source</b>	SMD LED 4000K
<b>Class</b>	I
<b>CRI</b>	>80
<b>Voltage (V/Hz)</b>	110V/50-60Hz

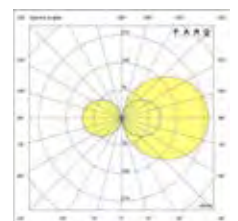
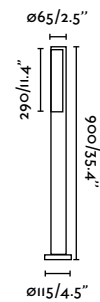
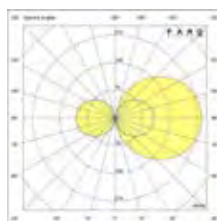
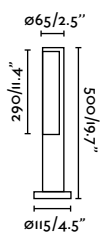



outdoor

Floor



Beret 900 75523-110

## Logar 650

IP54 IK10 incl.



75605

● Dark Grey

<b>Material</b>	<b>Body</b> Aluminium
	<b>Diff</b> Opal PMMA
<b>Power</b>	12W
<b>Lumen Output</b>	580lm
<b>Light Source</b>	SMD LED 3000K
<b>Class</b>	I
<b>CRI</b>	>80
<b>Voltage (V/Hz)</b>	100V-240V/50-60Hz

## Logar 900

IP54 IK10 incl.



75606

● Dark Grey

<b>Material</b>	<b>Body</b> Aluminium
	<b>Diff</b> Opal PMMA
<b>Power</b>	23W
<b>Lumen Output</b>	1340lm
<b>Light Source</b>	SMD LED 3000K
<b>Class</b>	I
<b>CRI</b>	>80
<b>Voltage (V/Hz)</b>	100V-240V/50-60Hz

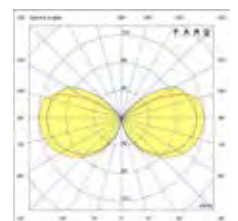
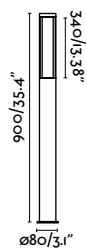
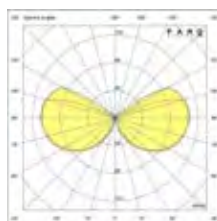
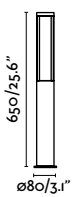

outdoor

Floor



Logar 650 75605

665



# Blubs Mistu Moon & Muffin

A timeless proposal  
capable of fitting into  
various outdoor  
atmospheres.



Muffin 259 74433S-04

Pleasant design for a  
highly versatile series.  
A polymethacrylate  
(PMMA) diffuser provides  
excellent, perfectly  
proportioned light.

Mistu 600 74434B-02

outdoor

Floor



Muffin 559 74434B-04

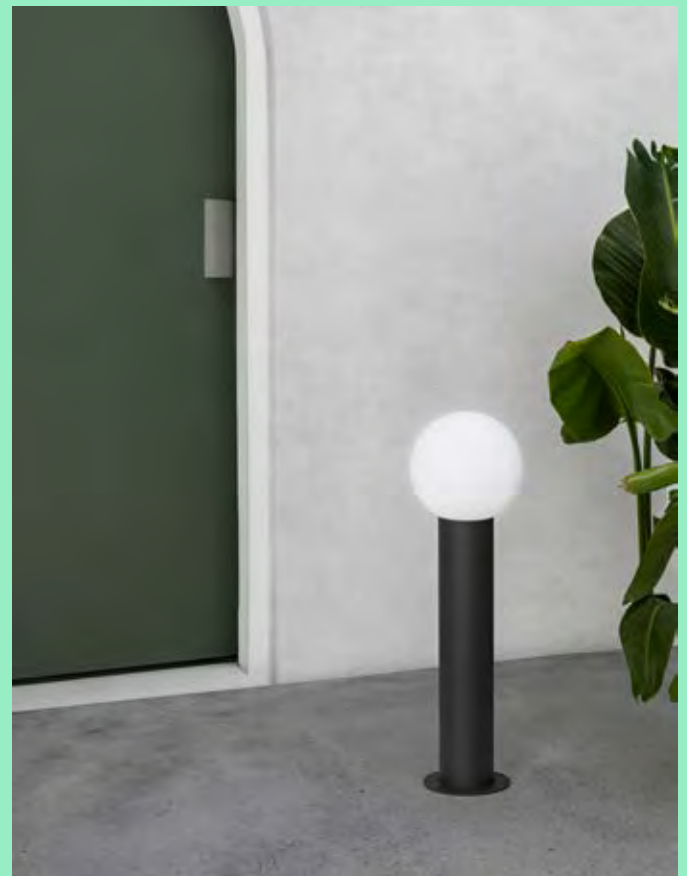

It is the search for the essence of light, and simplicity in shape. A full moon that floods everything around it with light.

Moon 610 74434B-01



**Muffin 259**  
Àlex & Manel Llusçà

IP44



74433S-04 ●● Dark Grey + Opal

<b>Material</b>	<b>Body</b> Aluminium
	<b>Diff</b> Opal PMMA
<b>Light Source</b>	1 E27 max. 15W
<b>Bulb incl.</b>	No
<b>Class</b>	I

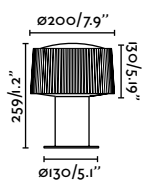
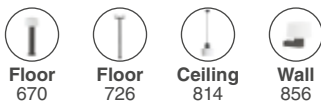

**Mistu 310**  
Faro Lab

IP44



74433S-02 ●● Dark Grey + Opal

<b>Material</b>	<b>Body</b> Aluminium
	<b>Diff</b> Opal PMMA
<b>Light Source</b>	1 E27 max. 15W
<b>Bulb incl.</b>	No
<b>Class</b>	I

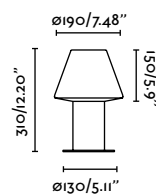
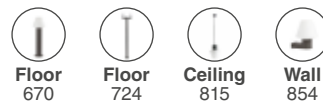

**Blubs 240**  
Estudi Ribaudí

IP44

**Moon 300**  
Faro Lab

IP44



74433S-03 ●● Dark Grey + Opal

74433S-01 ●● Dark Grey + Opal

<b>Material</b>	<b>Body</b> Aluminium
	<b>Diff</b> Opal PMMA
<b>Light Source</b>	1 E27 max. 15W
<b>Bulb incl.</b>	No
<b>Class</b>	I

<b>Material</b>	<b>Body</b> Aluminium
	<b>Diff</b> Opal PMMA
<b>Light Source</b>	1 E27 max. 15W
<b>Bulb incl.</b>	No
<b>Class</b>	I

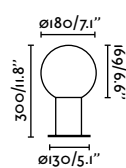
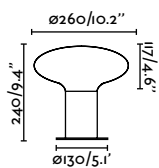
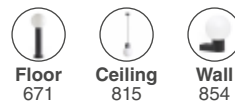
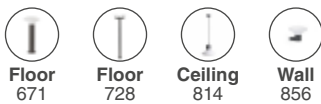

**Muffin 559**  
Àlex & Manel Llusçà

IP44



74434B-04 ● Dark Grey + Opal

<b>Material</b>	<b>Body</b> Aluminium
	<b>Diff</b> Opal PMMA
<b>Light Source</b>	1 E27 max. 15W
<b>Bulb incl.</b>	No
<b>Class</b>	I

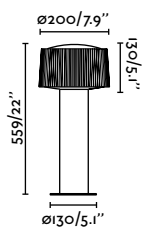
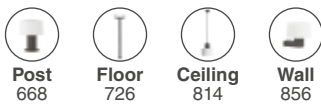

**Mistu 600**  
Faro Lab

IP44



74434B-02 ● Dark Grey + Opal

<b>Material</b>	<b>Body</b> Aluminium
	<b>Diff</b> Opal PMMA
<b>Light Source</b>	1 E27 max. 15W
<b>Bulb incl.</b>	No
<b>Class</b>	I

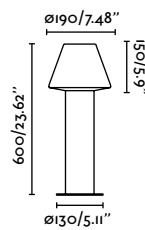
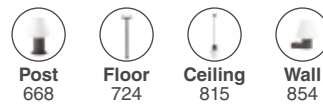

**Blubs 540**  
Estudi Ribaudí

IP44



74434B-03 ● Dark Grey + Opal

<b>Material</b>	<b>Body</b> Aluminium
	<b>Diff</b> Opal PMMA
<b>Light Source</b>	1 E27 max. 15W
<b>Bulb incl.</b>	No
<b>Class</b>	I

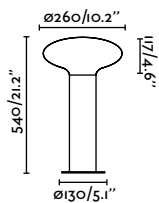
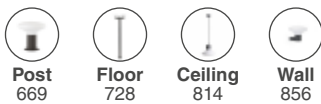

**Moon 610**  
Faro Lab

IP44



74434B-01 ● Dark Grey + Opal

<b>Material</b>	<b>Body</b> Aluminium
	<b>Diff</b> Opal PMMA
<b>Light Source</b>	1 E27 max. 15W
<b>Bulb incl.</b>	No
<b>Class</b>	I

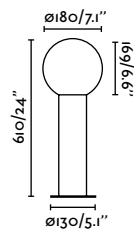
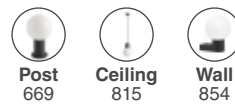

Noboru

IP65 IK08 incl.



70576

● Dark Grey

<b>Material</b>	<b>Body</b> Aluminium <b>Diff</b> Transparent Glass
<b>Power</b>	16W
<b>Lumen Output</b>	690lm
<b>Light Source</b>	COB LED 3000K
<b>Class</b>	I
<b>CRI</b>	>80
<b>Voltage (V/Hz)</b>	100V-240V/50Hz
<b>Beam angle</b>	36°

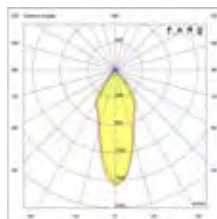
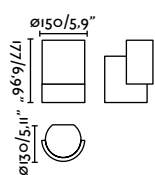

672



outdoor

Floor



## Mila

IP65  incl.



70771

  Dark Grey + Opal

<b>Material</b>	<b>Body</b> Aluminium
	<b>Diff</b> Opal PC
<b>Power</b>	18W
<b>Lumen Output</b>	500lm
<b>Light Source</b>	SMD LED 4000K
<b>Class</b>	I
<b>CRI</b>	>80
<b>Voltage (V/Hz)</b>	100V-240V/50-60Hz

## Nala

IP54 



70772-110

  Dark Grey + Transparent

<b>Material</b>	<b>Body</b> Aluminium
	<b>Diff</b> Transparent Glass
<b>Light Source</b>	1 E27 max. 15W
<b>Bulb incl.</b>	No
<b>Class</b>	I

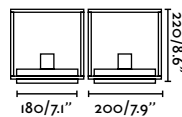
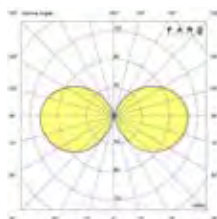
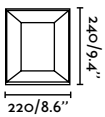

outdoor

Floor



Mila 70771

675

## Sete

IP54 IK04 incl.



75521

● Dark Grey + Opal

<b>Material</b>	<b>Body</b> Aluminium
	<b>Diff</b> Opal PC
<b>Power</b>	6W
<b>Lumen Output</b>	155lm
<b>Light Source</b>	SMD LED 3000K
<b>Class</b>	I
<b>CRI</b>	>80
<b>Voltage (V/Hz)</b>	100V-240V/50-60Hz

## Surat

IP54



72310

● Dark Grey + Transparent

<b>Material</b>	<b>Body</b> Aluminium
	<b>Diff</b> Transparent Glass
<b>Light Source</b>	1 E27 max. 15W
<b>Bulb incl.</b>	No
<b>Class</b>	I

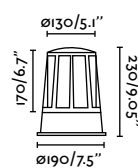
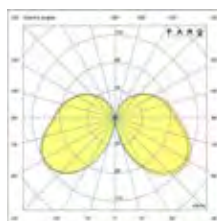
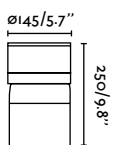





Sete 75521



Surat 72310



## Mauren

IP44 SEA SIDE  
SUITABLE



70993

● ● Brass + Transparent

<b>Material</b>	<b>Body Brass</b>
	<b>Diff Transparent Glass</b>
<b>Light Source</b>	1 E27 max. 15W
<b>Bulb incl.</b>	No
<b>Class</b>	I

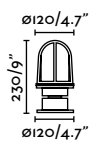



**Shadow 250**  
Àlex & Manel Llusçà

IP65 IK08 incl.



72311-110 ● Dark Grey

<b>Material</b>	<b>Body</b> Aluminium <b>Diff</b> Opal Glass
<b>Power</b>	11W
<b>Lumen Output</b>	800lm
<b>Light Source</b>	SMD LED 3000K
<b>Class</b>	I
<b>CRI</b>	>80
<b>Voltage (V/Hz)</b>	110V/50-60Hz

**Shadow 450**  
Àlex & Manel Llusçà

IP65 IK08 incl.



72312-110 ● Dark Grey

<b>Material</b>	<b>Body</b> Aluminium <b>Diff</b> Opal Glass
<b>Power</b>	11W
<b>Lumen Output</b>	800lm
<b>Light Source</b>	SMD LED 3000K
<b>Class</b>	I
<b>CRI</b>	>80
<b>Voltage (V/Hz)</b>	110V/50-60Hz

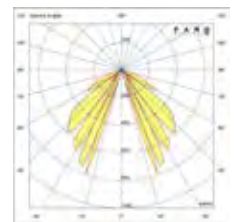
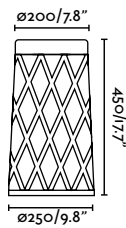
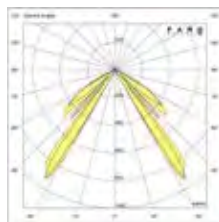
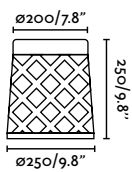

# Shadow

**Design** Àlex & Manel Lluscà

Shadow reinvents the concept of garden beacons. Place several pieces along a path and you'll get an amazing effect.





**Bu-Oh 265**  
Estudi Ribaudí

IP65  incl.



71213 ● Dark Grey

<b>Material</b>	<b>Body</b> Aluminium <b>Diff</b> Opal PC
<b>Power</b>	12W
<b>Lumen Output</b>	310lm
<b>Light Source</b>	SMD LED 3000K
<b>Class</b>	I
<b>CRI</b>	>80
<b>Voltage (V/Hz)</b>	100V-240V/50-60Hz

**Bu-Oh 560**  
Estudi Ribaudí

IP65  incl.



71214 ● Dark Grey

<b>Material</b>	<b>Body</b> Aluminium <b>Diff</b> Opal PC
<b>Power</b>	12W
<b>Lumen Output</b>	310lm
<b>Light Source</b>	SMD LED 3000K
<b>Class</b>	I
<b>CRI</b>	>80
<b>Voltage (V/Hz)</b>	100V-240V/50-60Hz

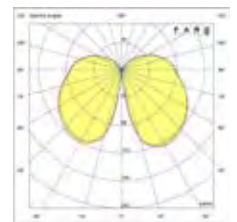
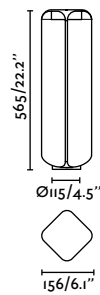
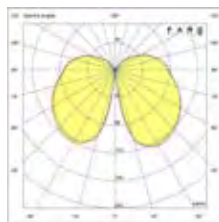
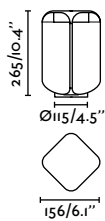
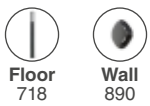



# Bu-Oh

**Design** Estudi Ribaudí



Bu-Oh 265 71213

Bu-oh! is a collection of intimidating-looking outdoor luminaires with unparalleled elegance and beauty. Ideal for signalling outdoor environments in an original and ingenious way.



Bu-Oh 560 71214

## Das 300

IP54 IK09 incl.



75519

● Dark Grey

<b>Material</b>	Body Aluminium
	Diff Transparent Glass
<b>Power</b>	8W
<b>Lumen Output</b>	480lm
<b>Light Source</b>	COB LED 3000K
<b>Class</b>	I
<b>CRI</b>	>80
<b>Voltage (V/Hz)</b>	100V-240V/50-60Hz
<b>Beam angle</b>	180°

## Das 650

IP54 IK09 incl.



75520

● Dark Grey

<b>Material</b>	Body Aluminium
	Diff Transparent Glass
<b>Power</b>	8W
<b>Lumen Output</b>	480lm
<b>Light Source</b>	COB LED 3000K
<b>Class</b>	I
<b>CRI</b>	>80
<b>Voltage (V/Hz)</b>	100V-240V/50-60Hz
<b>Beam angle</b>	180°

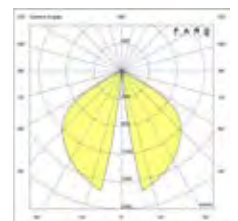
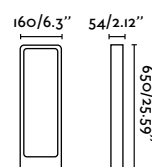
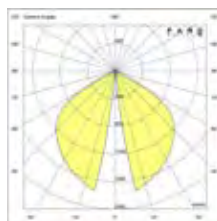
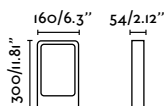

outdoor

Floor



Das 300 75519

685

## Naya 200

IP54  incl.



71198

● Dark Grey

<b>Material</b>	<b>Body Aluminium</b>
	<b>Diff Transparent PC</b>
<b>Power</b>	8W
<b>Lumen Output</b>	180lm
<b>Light Source</b>	SMD LED 3000K
<b>Class</b>	I
<b>CRI</b>	>80
<b>Voltage (V/Hz)</b>	100V-240V/50-60Hz
<b>Beam angle</b>	120°

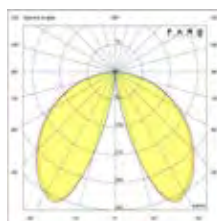
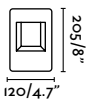

## Naya 500

IP54  incl.



71199

● Dark Grey

<b>Material</b>	<b>Body Aluminium</b>
	<b>Diff Transparent PC</b>
<b>Power</b>	8W
<b>Lumen Output</b>	180lm
<b>Light Source</b>	SMD LED 3000K
<b>Class</b>	I
<b>CRI</b>	>80
<b>Voltage (V/Hz)</b>	100V-240V/50-60Hz
<b>Beam angle</b>	120°

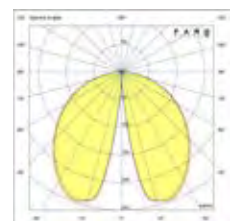
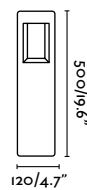



outdoor

Floor



Naya 200 71198



## Agra 200

IP55  incl.

NEW  
2700K



- 70755 3000K  Dark Grey
- 70756 3000K  Brown
- 70840 2700K  Dark Grey
- 70841 2700K  Brown

<b>Material</b>	<b>Body</b> Aluminium
	<b>Diff</b> Transparent Glass
<b>Power</b>	9W
<b>Lumen Output</b>	647lm [3000K] 503lm [2700K]
<b>Light Source</b>	COB LED
<b>Class</b>	I
<b>CRI</b>	>80
<b>Voltage (V/Hz)</b>	100V-240V/50-60Hz

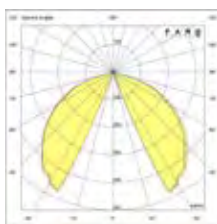
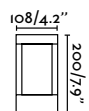

## Agra 650

IP55  incl.

NEW  
2700K



- 70753 3000K  Dark Grey
- 70754 3000K  Brown
- 70842 2700K  Dark Grey
- 70843 2700K  Brown

<b>Material</b>	<b>Body</b> Aluminium
	<b>Diff</b> Transparent Glass
<b>Power</b>	9W
<b>Lumen Output</b>	647lm [3000K] 503lm [2700K]
<b>Light Source</b>	COB LED
<b>Class</b>	I
<b>CRI</b>	>80
<b>Voltage (V/Hz)</b>	100V-240V/50-60Hz

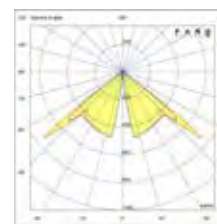
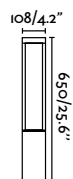

outdoor

Floor



Agra 650 70753



Agra 650 70754

## Gina

IP44



71352

● Dark Grey

<b>Material</b>	<b>Body</b> Aluminium
	<b>Diff</b> Transparent Glass
<b>Light Source</b>	1 GU10 max. 5W
<b>Bulb incl.</b>	No
<b>Class</b>	I

## Onze

IP54 IK05



70761

● Dark Grey

<b>Material</b>	<b>Body</b> Aluminium
	<b>Diff</b> Opal PC
<b>Light Source</b>	1 E27 max. 15W
<b>Bulb incl.</b>	No
<b>Class</b>	I



Wall  
922

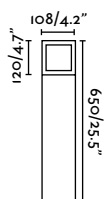
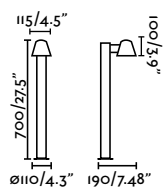



**Klamp**  
Àlex & Manel Lluscà

IP44



74411

● Dark Grey

<b>Material</b>	<b>Body</b> Aluminium
	<b>Diff</b> Opal PC
<b>Light Source</b>	1 E27 max. 15W
<b>Bulb incl.</b>	No
<b>Class</b>	I



Wall  
930

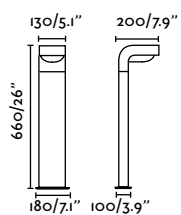



# Klamp

Design Àlex & Manel Llusçà

Modern and robust line design. Made of injected aluminium and polycarbonate diffuser, it is available as a wall lamp and beacon.



## Soleil

IP54 IK07 incl. PIR solar



70785 ● Dark Grey

<b>Material</b>	Body Aluminium Diff Opal PMMA
<b>Power</b>	2W
<b>Lumen Output</b>	140lm
<b>Light Source</b>	SMD LED 3000K
<b>Class</b>	III
<b>CRI</b>	>80
	7h Charge Max. 3h Worktime

## Saura

IP54 incl. PIR solar



70774 ● Dark Grey

<b>Material</b>	Body Aluminium Diff Opal PC
<b>Power</b>	2W
<b>Lumen Output</b>	225lm
<b>Light Source</b>	SMD LED 3000K
<b>Class</b>	III
<b>CRI</b>	>80
<b>Beam angle</b>	180°
	8h Charge Max. 2,5h Worktime

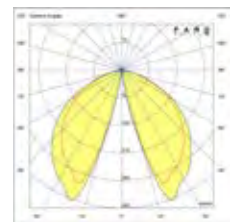
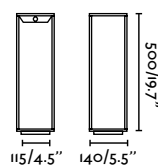
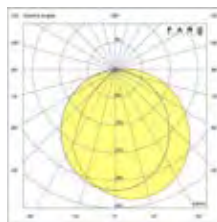
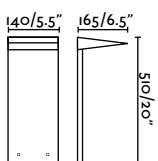



Saura 70774



Soleil 70785



**Bezel**  
Faro Lab

IP65 IK06 incl. IP68 CONNECTOR



70247-110 ● Matt Black

	Diff Transparent Glass
<b>Power</b>	8W
<b>Lumen Output</b>	349lm
<b>Light Source</b>	COB LED 2700K
<b>CRI</b>	90
<b>Voltage (V/Hz)</b>	110V/50-60Hz

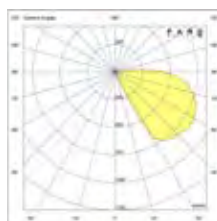
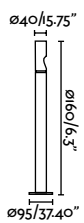



outdoor

Floor





# Rush & Screen

**Design** Estudi Ribaudí

This complete line of products offers versatile solutions such as pole lamp, bollards and post lamps, standing out for their sober and minimalist yet robust design.



outdoor

Floor



699

It has three different optical options, allowing it to adapt to the specific needs of each project and providing efficient and long-lasting lighting.

Electronics and optics by *VOSSLOH-SCHWABE*



Optional drivers by *TCI*



Different optics to choose from

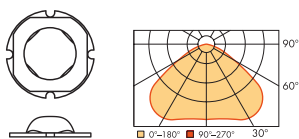

**360° LENS**  
**Optical efficiency 97%**  
**Optimal installation ratio 2:1**  
 (Pole distance to pole height)

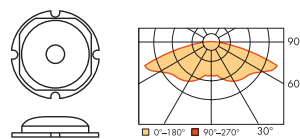

**360° WIDE LENS**  
**Optical efficiency 96%**  
**Optimal installation ratio 4,5:1**  
 (Pole distance to pole height)

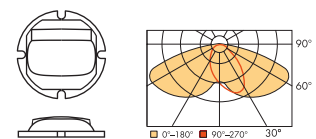

**ASSYMETRICAL LENS**  
**Optical efficiency 93%**  
**Optimal installation ratio 4:1**  
 (Pole distance to pole height)





# Rush 250

## Estudi Ribaudi



<b>Body</b>	Aluminium	<b>COB LED</b>	VOSSLOH-SCHWABE
<b>Diff</b>	Transparent Polycarbonate	<b>MacAdam Steps</b>	2
		<b>Risk Group</b>	1
		<b>Lumen maintenance</b>	L90 B10 up to 89.000h
		<b>Heat dissipation</b>	Tested at high ambient temperature

	Power	Light Source	CCT	Lumen Output	Voltage (V/Hz)	Lens
750000	14W	868lm	COB LED	2700K	100V-240V/50-60Hz	360°
750001	14W	1016lm	COB LED	2700K	100V-240V/50-60Hz	360° WIDE
750002	14W	961lm	COB LED	2700K	100V-240V/50-60Hz	180°
750010	14W	895lm	COB LED	3000K	100V-240V/50-60Hz	360°
750011	14W	1047lm	COB LED	3000K	100V-240V/50-60Hz	360° WIDE
750012	14W	991lm	COB LED	3000K	100V-240V/50-60Hz	180°
750020	14W	922lm	COB LED	4000K	100V-240V/50-60Hz	360°
750021	14W	1078lm	COB LED	4000K	100V-240V/50-60Hz	360° WIDE
750022	14W	1021lm	COB LED	4000K	100V-240V/50-60Hz	180°
750000D-110	14W	830lm	COB LED	2700K	110V/50-60Hz	360°
750001D-110	14W	980lm	COB LED	2700K	110V/50-60Hz	360° WIDE
750002D-110	14W	795lm	COB LED	2700K	110V/50-60Hz	180°
750010D-110	14W	830lm	COB LED	3000K	110V/50-60Hz	360°
750011D-110	14W	980lm	COB LED	3000K	110V/50-60Hz	360° WIDE
750012D-110	14W	795lm	COB LED	3000K	110V/50-60Hz	180°
750020D-110	14W	830lm	COB LED	4000K	110V/50-60Hz	360°
750021D-110	14W	980lm	COB LED	4000K	110V/50-60Hz	360° WIDE
750022D-110	14W	795lm	COB LED	4000K	110V/50-60Hz	180°

STANDARD Driver incl. VS LIGHTING SOLUTIONS

\*DALI option



### VOSSLOH-SCHWABE

<b>Beacon mA</b>	350mA
<b>Bollard mA</b>	500mA
<b>V</b>	100-240V
<b>Hz</b>	50-60Hz
<b>Power factor</b>	0.90
<b>Low ripple</b>	<5%
<b>Lifetime</b>	50000h

Overload protection  
Short-circuit protection  
Overheating protection  
SELV (Safety Extra Low Voltage)

### TCI

<b>Beacon mA</b>	350mA
<b>Bollard mA</b>	500mA
<b>V</b>	220-240V
<b>Hz</b>	50-60Hz
<b>Power factor</b>	0.95
<b>Low ripple</b>	<3%
<b>Lifetime</b>	50000h

DALI-2 dimmable  
PUSH SWITCH compatible  
Overload protection  
Short-circuit protection  
Overheating protection  
SELV (Safety Extra Low Voltage)

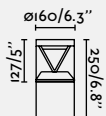



outdoor

Floor



# Rush 800

## Estudi Ribaudí

IP65  CRI90 IK10  Driver incl. optional 

**Body** Aluminium  
**Diff** Transparent Polycarbonate

**COB LED**  
**MacAdam Steps**  
**Risk Group**  
**Lumen maintenance**  
**Heat dissipation**

*VOSSLOH-SCHWABE*  
2  
1  
L90 B10 up to 89.000h  
Tested at high ambient temperature

	Power	Light Source	CCT	Lumen Output	Voltage (V/Hz)	Lens
750100	20W	1185lm	COB LED	2700K	100V-240V/50-60Hz	360°
750101	20W	1476lm	COB LED	2700K	100V-240V/50-60Hz	360° WIDE
750102	20W	1343lm	COB LED	2700K	100V-240V/50-60Hz	180°
750110	20W	1222lm	COB LED	3000K	100V-240V/50-60Hz	360°
750111	20W	1522lm	COB LED	3000K	100V-240V/50-60Hz	360° WIDE
750112	20W	1385lm	COB LED	3000K	100V-240V/50-60Hz	180°
750120	20W	1259lm	COB LED	4000K	100V-240V/50-60Hz	360°
750121	20W	1568lm	COB LED	4000K	100V-240V/50-60Hz	360° WIDE
750122	20W	1427lm	COB LED	4000K	100V-240V/50-60Hz	180°
750100D-110	20W	1147lm	COB LED	2700K	110V/50-60Hz	360°
750101D-110	20W	1355lm	COB LED	2700K	110V/50-60Hz	360° WIDE
750102D-110	20W	1103lm	COB LED	2700K	110V/50-60Hz	180°
750110D-110	20W	1147lm	COB LED	3000K	110V/50-60Hz	360°
750111D-110	20W	1355lm	COB LED	3000K	110V/50-60Hz	360° WIDE
750112D-110	20W	1103lm	COB LED	3000K	110V/50-60Hz	180°
750120D-110	20W	1147lm	COB LED	4000K	110V/50-60Hz	360°
750121D-110	20W	1355lm	COB LED	4000K	110V/50-60Hz	360° WIDE
750122D-110	20W	1103lm	COB LED	4000K	110V/50-60Hz	180°

STANDARD Driver incl. 

\*DALI option



*VOSSLOH-SCHWABE*

**Beacon mA** 350mA  
**Bollard mA** 500mA  
**V** 100-240V  
**Hz** 50-60Hz  
**Power factor** 0.90  
**Low ripple** <5%  
**Lifetime** 50000h

Overload protection  
Short-circuit protection  
Overheating protection  
SELV (Safety Extra Low Voltage)

*TCI*

**Beacon mA** 350mA  
**Bollard mA** 500mA  
**V** 220-240V  
**Hz** 50-60Hz  
**Power factor** 0.95  
**Low ripple** <3%  
**Lifetime** 50000h

DALI-2 dimmable  
PUSH SWITCH compatible  
Overload protection  
Short-circuit protection  
Overheating protection  
SELV (Safety Extra Low Voltage)

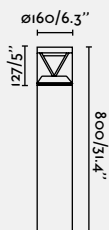



# Rush 3100

## Estudi Ribaudi



**Body** Aluminium  
**Diff** Transparent Polycarbonate

**COB LED**  
**MacAdam Steps**  
**Risk Group**  
**Lumen maintenance**  
**Heat dissipation**

**VOSSLOH-SCHWABE**  
2  
1  
L90 B10 up to 89.000h  
Tested at high ambient temperature

	Power	Light Source	CCT	Lumen Output	Voltage (V/Hz)	Lens
750200	38W	3738lm	COB LED	2700K	100V-240V/50-60Hz	360°
750201	38W	3748lm	COB LED	2700K	100V-240V/50-60Hz	360° WIDE
750202	38W	3664lm	COB LED	2700K	100V-240V/50-60Hz	180°
750210	38W	3854lm	COB LED	3000K	100V-240V/50-60Hz	360°
750211	38W	3864lm	COB LED	3000K	100V-240V/50-60Hz	360° WIDE
750212	38W	3777lm	COB LED	3000K	100V-240V/50-60Hz	180°
750220	38W	3970lm	COB LED	4000K	100V-240V/50-60Hz	360°
750221	38W	3980lm	COB LED	4000K	100V-240V/50-60Hz	360° WIDE
750222	38W	3890lm	COB LED	4000K	100V-240V/50-60Hz	180°
750200D-110	38W	3322lm	COB LED	2700K	110V/50-60Hz	360°
750201D-110	38W	3079lm	COB LED	2700K	110V/50-60Hz	360° WIDE
750202D-110	38W	2397lm	COB LED	2700K	110V/50-60Hz	180°
750210D-110	38W	3322lm	COB LED	3000K	110V/50-60Hz	360°
750211D-110	38W	3079lm	COB LED	3000K	110V/50-60Hz	360° WIDE
750212D-110	38W	2397lm	COB LED	3000K	110V/50-60Hz	180°
750220D-110	38W	3322lm	COB LED	4000K	110V/50-60Hz	360°
750221D-110	38W	3079lm	COB LED	4000K	110V/50-60Hz	360° WIDE
750222D-110	38W	2397lm	COB LED	4000K	110V/50-60Hz	180°

STANDARD Driver incl. VS LIGHTING SOLUTIONS

\*DALI option



**VOSSLOH-SCHWABE**

**mA** 1050mA  
**V** 100-240V  
**Hz** 50-60Hz  
**Power factor** 0.90  
**Low ripple** <5%  
**Lifetime** 50000h

Overload protection  
Short-circuit protection  
Overheating protection  
SELV (Safety Extra Low Voltage)

**TCI**

**mA** 1050mA  
**V** 220-240V  
**Hz** 50-60Hz  
**Power factor** 0.95  
**Low ripple** <3%  
**Lifetime** 50000h

DALI-2 dimmable  
PUSH SWITCH compatible  
Overload protection  
Short-circuit protection  
Overheating protection  
SELV (Safety Extra Low Voltage)

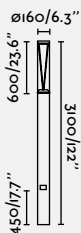

outdoor

Floor



Rush 750210 Simulation  
38W  
3000K  
Optics 360°  
Luminaires interdistance 10mt.



# Rush 3700

Estudi Ribaudi



**Body** Aluminium  
**Diff** Transparent Polycarbonate

**COB LED**  
**MacAdam Steps**  
**Risk Group**  
**Lumen maintenance**  
**Heat dissipation**

**VOSSLOH-SCHWABE**  
2  
1  
L90 B10 up to 89.000h  
Tested at high ambient temperature

	Power	Light Source	CCT	Lumen Output	Voltage (V/Hz)	Lens
750300	38W	3943lm	COB LED	2700K	100V-240V/50-60Hz	360°
750301	38W	3997lm	COB LED	2700K	100V-240V/50-60Hz	360° WIDE
750302	38W	3726lm	COB LED	2700K	100V-240V/50-60Hz	180°
750310	38W	4065lm	COB LED	3000K	100V-240V/50-60Hz	360°
750311	38W	4121lm	COB LED	3000K	100V-240V/50-60Hz	360° WIDE
750312	38W	3841lm	COB LED	3000K	100V-240V/50-60Hz	180°
750320	38W	4187lm	COB LED	4000K	100V-240V/50-60Hz	360°
750321	38W	4245lm	COB LED	4000K	100V-240V/50-60Hz	360° WIDE
750322	38W	3956lm	COB LED	4000K	100V-240V/50-60Hz	180°
750300D-110	38W	2972lm	COB LED	2700K	110V/50-60Hz	360°
750301D-110	38W	2921lm	COB LED	2700K	110V/50-60Hz	360° WIDE
750302D-110	38W	2576lm	COB LED	2700K	110V/50-60Hz	180°
750310D-110	38W	2972lm	COB LED	3000K	110V/50-60Hz	360°
750311D-110	38W	2921lm	COB LED	3000K	110V/50-60Hz	360° WIDE
750312D-110	38W	2576lm	COB LED	3000K	110V/50-60Hz	180°
750320D-110	38W	2972lm	COB LED	4000K	110V/50-60Hz	360°
750321D-110	38W	2921lm	COB LED	4000K	110V/50-60Hz	360° WIDE
750322D-110	38W	2576lm	COB LED	4000K	110V/50-60Hz	180°

STANDARD Driver incl. VS LIGHTING SOLUTIONS

\*DALI option



**VOSSLOH-SCHWABE**

**mA** 1050mA  
**V** 100-240V  
**Hz** 50-60Hz  
**Power factor** 0.90  
**Low ripple** <5%  
**Lifetime** 50000h

Overload protection  
Short-circuit protection  
Overheating protection  
SELV (Safety Extra Low Voltage)

**TCI**

**mA** 1050mA  
**V** 220-240V  
**Hz** 50-60Hz  
**Power factor** 0.95  
**Low ripple** <3%  
**Lifetime** 50000h

DALI-2 dimmable  
PUSH SWITCH compatible  
Overload protection  
Short-circuit protection  
Overheating protection  
SELV (Safety Extra Low Voltage)

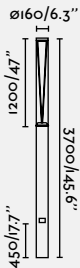

outdoor

Floor



Simulation Rush 750311  
38W  
3000K  
Optics 360°  
Luminares interdistance 12mt.

# Screen 250

Estudi Ribaudi



<b>Body</b>	Aluminium	<b>COB LED</b>	VOSSLOH-SCHWABE
<b>Diff</b>	Transparent Polycarbonate	<b>MacAdam Steps</b>	2
		<b>Risk Group</b>	1
		<b>Lumen maintenance</b>	L90 B10 up to 89.000h
		<b>Heat dissipation</b>	Tested at high ambient temperature

	Power	Light Source	CCT	Lumen Output	Voltage (V/Hz)	Lens
751000	14W	623lm	COB LED	2700K	100V-240V/50-60Hz	360°
751001	14W	778lm	COB LED	2700K	100V-240V/50-60Hz	360° WIDE
751002	14W	601lm	COB LED	2700K	100V-240V/50-60Hz	180°
751010	14W	642lm	COB LED	3000K	100V-240V/50-60Hz	360°
751011	14W	802lm	COB LED	3000K	100V-240V/50-60Hz	360° WIDE
751012	14W	620lm	COB LED	3000K	100V-240V/50-60Hz	180°
751020	14W	661lm	COB LED	4000K	100V-240V/50-60Hz	360°
751021	14W	826lm	COB LED	4000K	100V-240V/50-60Hz	360° WIDE
751022	14W	639lm	COB LED	4000K	100V-240V/50-60Hz	180°
751000D-110	14W	712lm	COB LED	2700K	110V/50-60Hz	360°
751001D-110	14W	856lm	COB LED	2700K	110V/50-60Hz	360° WIDE
751002D-110	14W	695lm	COB LED	2700K	110V/50-60Hz	180°
751010D-110	14W	712lm	COB LED	3000K	110V/50-60Hz	360°
751011D-110	14W	856lm	COB LED	3000K	110V/50-60Hz	360° WIDE
751012D-110	14W	695lm	COB LED	3000K	110V/50-60Hz	180°
751020D-110	14W	712lm	COB LED	4000K	110V/50-60Hz	360°
751021D-110	14W	856lm	COB LED	4000K	110V/50-60Hz	360° WIDE
751022D-110	14W	695lm	COB LED	4000K	110V/50-60Hz	180°

STANDARD Driver incl. VS LIGHTING SOLUTIONS

\*DALI option



**VOSSLOH-SCHWABE**

<b>Beacon mA</b>	350mA
<b>Bollard mA</b>	500mA
<b>V</b>	100-240V
<b>Hz</b>	50-60Hz
<b>Power factor</b>	0.90
<b>Low ripple</b>	<5%
<b>Lifetime</b>	50000h

Overload protection  
Short-circuit protection  
Overheating protection  
SELV (Safety Extra Low Voltage)

**TCI**

<b>Beacon mA</b>	350mA
<b>Bollard mA</b>	500mA
<b>V</b>	220-240V
<b>Hz</b>	50-60Hz
<b>Power factor</b>	0.95
<b>Low ripple</b>	<3%
<b>Lifetime</b>	50000h

DALI-2 dimmable  
PUSH SWITCH compatible  
Overload protection  
Short-circuit protection  
Overheating protection  
SELV (Safety Extra Low Voltage)

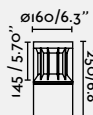



# Screen 800

Estudi Ribaudi



<b>Body</b>	Aluminium	<b>COB LED</b>	VOSSLOH-SCHWABE
<b>Diff</b>	Transparent Polycarbonate	<b>MacAdam Steps</b>	2
		<b>Risk Group</b>	1
		<b>Lumen maintenance</b>	L90 B10 up to 89.000h
		<b>Heat dissipation</b>	Tested at high ambient temperature

	Power	Light Source	CCT	Lumen Output	Voltage (V/Hz)	Lens
751100	20W	873lm	COB LED	2700K	100V-240V/50-60Hz	360°
751101	20W	1098lm	COB LED	2700K	100V-240V/50-60Hz	360° WIDE
751102	20W	855lm	COB LED	2700K	100V-240V/50-60Hz	180°
751110	20W	900lm	COB LED	3000K	100V-240V/50-60Hz	360°
751111	20W	1132lm	COB LED	3000K	100V-240V/50-60Hz	360° WIDE
751112	20W	881lm	COB LED	3000K	100V-240V/50-60Hz	180°
751120	20W	927lm	COB LED	4000K	100V-240V/50-60Hz	360°
751121	20W	1166lm	COB LED	4000K	100V-240V/50-60Hz	360° WIDE
751122	20W	907lm	COB LED	4000K	100V-240V/50-60Hz	180°
751100D-110	20W	990lm	COB LED	2700K	110V/50-60Hz	360°
751101D-110	20W	1225lm	COB LED	2700K	110V/50-60Hz	360° WIDE
751102D-110	20W	965lm	COB LED	2700K	110V/50-60Hz	180°
751110D-110	20W	990lm	COB LED	3000K	110V/50-60Hz	360°
751111D-110	20W	1225lm	COB LED	3000K	110V/50-60Hz	360° WIDE
751112D-110	20W	965lm	COB LED	3000K	110V/50-60Hz	180°
751120D-110	20W	990lm	COB LED	4000K	110V/50-60Hz	360°
751121D-110	20W	1225lm	COB LED	4000K	110V/50-60Hz	360° WIDE
751122D-110	20W	965lm	COB LED	4000K	110V/50-60Hz	180°

STANDARD Driver incl. VS LIGHTING SOLUTIONS

\*DALI option



**VOSSLOH-SCHWABE**

<b>Beacon mA</b>	350mA
<b>Bollard mA</b>	500mA
<b>V</b>	100-240V
<b>Hz</b>	50-60Hz
<b>Power factor</b>	0.90
<b>Low ripple</b>	<5%
<b>Lifetime</b>	50000h

Overload protection  
Short-circuit protection  
Overheating protection  
SELV (Safety Extra Low Voltage)

**TCI**

<b>Beacon mA</b>	350mA
<b>Bollard mA</b>	500mA
<b>V</b>	220-240V
<b>Hz</b>	50-60Hz
<b>Power factor</b>	0.95
<b>Low ripple</b>	<3%
<b>Lifetime</b>	50000h

DALI-2 dimmable  
PUSH SWITCH compatible  
Overload protection  
Short-circuit protection  
Overheating protection  
SELV (Safety Extra Low Voltage)

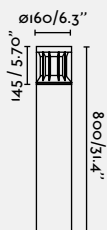





# Screen 3100

Estudi Ribaudi



**Body** Aluminium  
**Diff** Transparent Polycarbonate

**COB LED**  
**MacAdam Steps**  
**Risk Group**  
**Lumen maintenance**  
**Heat dissipation**

**VOSSLOH-SCHWABE**  
2  
1  
L90 B10 up to 89.000h  
Tested at high ambient temperature

	Power	Light Source	CCT	Lumen Output	Voltage (V/Hz)	Lens
751200	38W	2641lm	COB LED	2700K	100V-240V/50-60Hz	360°
751201	38W	2581lm	COB LED	2700K	100V-240V/50-60Hz	360° WIDE
751202	38W	2304lm	COB LED	2700K	100V-240V/50-60Hz	180°
751210	38W	2723lm	COB LED	3000K	100V-240V/50-60Hz	360°
751211	38W	2661lm	COB LED	3000K	100V-240V/50-60Hz	360° WIDE
751212	38W	2375lm	COB LED	3000K	100V-240V/50-60Hz	180°
751220	38W	2805lm	COB LED	4000K	100V-240V/50-60Hz	360°
751221	38W	2741lm	COB LED	4000K	100V-240V/50-60Hz	360° WIDE
751222	38W	2446lm	COB LED	4000K	100V-240V/50-60Hz	180°
751200D-110	38W	2370lm	COB LED	2700K	110V/50-60Hz	360°
751201D-110	38W	2692lm	COB LED	2700K	110V/50-60Hz	360° WIDE
751202D-110	38W	1819lm	COB LED	2700K	110V/50-60Hz	180°
751210D-110	38W	2370lm	COB LED	3000K	110V/50-60Hz	360°
751211D-110	38W	2692lm	COB LED	3000K	110V/50-60Hz	360° WIDE
751212D-110	38W	1819lm	COB LED	3000K	110V/50-60Hz	180°
751220D-110	38W	2370lm	COB LED	4000K	110V/50-60Hz	360°
751221D-110	38W	2692lm	COB LED	4000K	110V/50-60Hz	360° WIDE
751222D-110	38W	1819lm	COB LED	4000K	110V/50-60Hz	180°

STANDARD Driver incl. VS LIGHTING SOLUTIONS

\*DALI option



**VOSSLOH-SCHWABE**

**mA** 1050mA  
**V** 100-240V  
**Hz** 50-60Hz  
**Power factor** 0.90  
**Low ripple** <5%  
**Lifetime** 50000h

Overload protection  
Short-circuit protection  
Overheating protection  
SELV (Safety Extra Low Voltage)

**TCI**

**mA** 1050mA  
**V** 220-240V  
**Hz** 50-60Hz  
**Power factor** 0.95  
**Low ripple** <3%  
**Lifetime** 50000h

DALI-2 dimmable  
PUSH SWITCH compatible  
Overload protection  
Short-circuit protection  
Overheating protection  
SELV (Safety Extra Low Voltage)

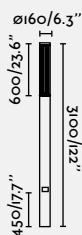

outdoor

Floor



Simulation Screen 751311  
38W  
3000K  
Optics 360°  
Luminares interdistance 12mt.

# Screen 3700

Estudi Ribaudi

IP65  CRI90 IK10  Driver incl. optional 

**Body** Aluminium  
**Diff** Transparent Polycarbonate

**COB LED**  
**MacAdam Steps**  
**Risk Group**  
**Lumen maintenance**  
**Heat dissipation**

*VOSSLOH-SCHWABE*  
2  
1  
L90 B10 up to 89.000h  
Tested at high ambient temperature

	Power	Light Source	CCT	Lumen Output	Voltage (V/Hz)	Lens
751300	38W	2578lm	COB LED	2700K	100V-240V/50-60Hz	360°
751301	38W	2560lm	COB LED	2700K	100V-240V/50-60Hz	360° WIDE
751302	38W	2429lm	COB LED	2700K	100V-240V/50-60Hz	180°
751310	38W	2658lm	COB LED	3000K	100V-240V/50-60Hz	360°
751311	38W	2639lm	COB LED	3000K	100V-240V/50-60Hz	360° WIDE
751312	38W	2504lm	COB LED	3000K	100V-240V/50-60Hz	180°
751320	38W	2738lm	COB LED	4000K	100V-240V/50-60Hz	360°
751321	38W	2718lm	COB LED	4000K	100V-240V/50-60Hz	360° WIDE
751322	38W	2579lm	COB LED	4000K	100V-240V/50-60Hz	180°
751300D-110	38W	2661lm	COB LED	2700K	110V/50-60Hz	360°
751301D-110	38W	2145lm	COB LED	2700K	110V/50-60Hz	360° WIDE
751302D-110	38W	1656lm	COB LED	2700K	110V/50-60Hz	180°
751310D-110	38W	2661lm	COB LED	3000K	110V/50-60Hz	360°
751311D-110	38W	2145lm	COB LED	3000K	110V/50-60Hz	360° WIDE
751312D-110	38W	1656lm	COB LED	3000K	110V/50-60Hz	180°
751320D-110	38W	2661lm	COB LED	4000K	110V/50-60Hz	360°
751321D-110	38W	2145lm	COB LED	4000K	110V/50-60Hz	360° WIDE
751322D-110	38W	1656lm	COB LED	4000K	110V/50-60Hz	180°

STANDARD Driver incl. 

\*DALI option



*VOSSLOH-SCHWABE*

**mA** 1050mA  
**V** 100-240V  
**Hz** 50-60Hz  
**Power factor** 0.90  
**Low ripple** <5%  
**Lifetime** 50000h

Overload protection  
Short-circuit protection  
Overheating protection  
SELV (Safety Extra Low Voltage)

*TCI*

**mA** 1050mA  
**V** 220-240V  
**Hz** 50-60Hz  
**Power factor** 0.95  
**Low ripple** <3%  
**Lifetime** 50000h

DALI-2 dimmable  
PUSH SWITCH compatible  
Overload protection  
Short-circuit protection  
Overheating protection  
SELV (Safety Extra Low Voltage)

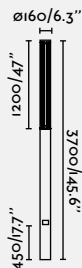

outdoor

Floor



Simulation Screen 751312  
38W  
3000K  
Optics 360°  
Luminares interdistance 10mt.



**Bu-Oh 2500**  
Estudi Ribaudí

IP65  incl.



71209 ● Dark Grey

<b>Material</b>	<b>Body</b> Aluminium <b>Diff</b> Opal PC
<b>Power</b>	30W
<b>Lumen Output</b>	2500lm
<b>Light Source</b>	SMD LED 3000K
<b>Class</b>	I
<b>CRI</b>	>80
<b>Voltage (V/Hz)</b>	100V-240V/50-60Hz



**Floor**  
682



**Wall**  
890

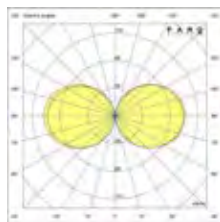
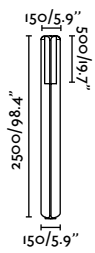

Bu-Oh

Design Estudi Ribaudí

outdoor

Floor

Bu-oh! is a collection of intimidating-looking outdoor luminaires with unparalleled elegance and beauty. Ideal for signalling outdoor environments in an original and ingenious way.



## Plaza

IP54 IK10 incl.



75607-110 ● Dark Grey

<b>Material</b>	<b>Body</b> Aluminium <b>Diff</b> Transparent PC
<b>Power</b>	24W
<b>Lumen Output</b>	1120lm
<b>Light Source</b>	SMD LED 3000K
<b>Class</b>	I
<b>CRI</b>	>80
<b>Voltage (V/Hz)</b>	110V/50-60Hz

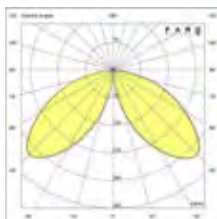
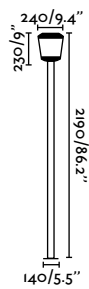



outdoor

Floor



## Grop 2000

IP54  
incl.



75602

● Dark Grey

<b>Material</b>	<b>Body</b> Aluminium <b>Diff</b> Opal PC
<b>Power</b>	27W
<b>Lumen Output</b>	1300lm
<b>Light Source</b>	SMD LED 3000K
<b>Class</b>	I
<b>CRI</b>	>80
<b>Voltage (V/Hz)</b>	100V-240V/50-60Hz

## Beret 1800

IP54 IK04  
incl.



75524-110

● Dark Grey

<b>Material</b>	<b>Body</b> Aluminium <b>Diff</b> Opal PMMA
<b>Power</b>	16W
<b>Lumen Output</b>	625lm
<b>Light Source</b>	SMD LED 4000K
<b>Class</b>	I
<b>CRI</b>	>80
<b>Voltage (V/Hz)</b>	110V/50-60Hz

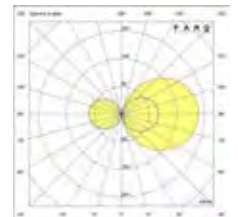
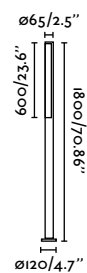
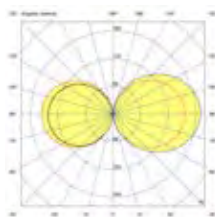





Beret 1800 75524-110

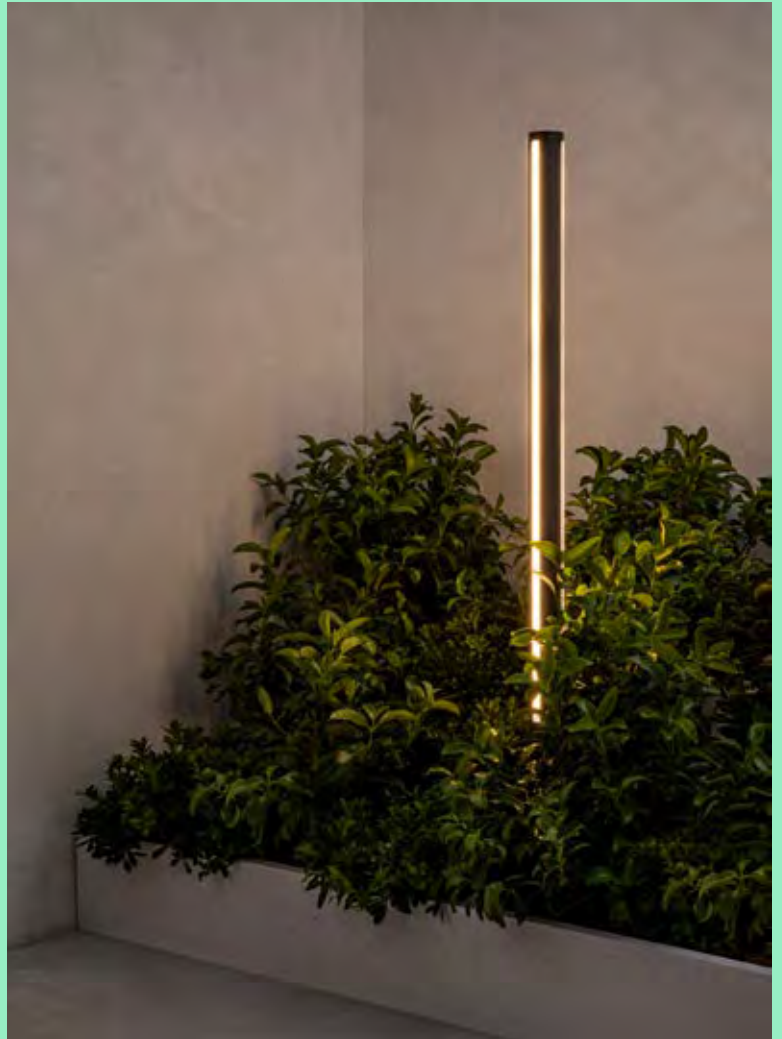

Grop 2000 75602

**Mistu 2L**  
Faro Lab

IP44



74435F2-02 ● Dark Grey + Opal

<b>Material</b>	<b>Body</b> Aluminium
	<b>Diff</b> Opal PMMA
<b>Light Source</b>	2 E27 max. 15W
<b>Bulb incl.</b>	No
<b>Class</b>	I

**Mistu 3L**  
Faro Lab

IP44



74436F3-02 ● Dark Grey + Opal

<b>Material</b>	<b>Body</b> Aluminium
	<b>Diff</b> Opal PMMA
<b>Light Source</b>	3 E27 max. 15W
<b>Bulb incl.</b>	No
<b>Class</b>	I



**Post**  
668



**Floor**  
670



**Ceiling**  
815



**Wall**  
854

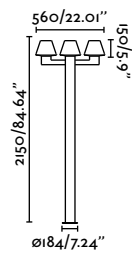
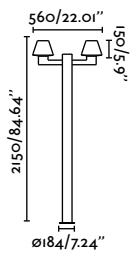

# Mistu

**Design** Faro Lab

Pleasant design for a highly versatile series. A polymethacrylate (PMMA) diffuser provides excellent, perfectly proportioned light.



Mistu 2L 74435F2-02

**Muffin 2L**  
Àlex & Manel Llusçà

IP44



74435F2-04 ●● Dark Grey + Opal

<b>Material</b>	<b>Body</b> Aluminium
	<b>Diff</b> Opal PMMA
<b>Light Source</b>	2 E27 max. 15W
<b>Bulb incl.</b>	No
<b>Class</b>	I

**Muffin 3L**  
Àlex & Manel Llusçà

IP44



74436F3-04 ●● Dark Grey + Opal

<b>Material</b>	<b>Body</b> Aluminium
	<b>Diff</b> Opal PMMA
<b>Light Source</b>	3 E27 max. 15W
<b>Bulb incl.</b>	No
<b>Class</b>	I



**Post**  
668



**Floor**  
670



**Ceiling**  
814



**Wall**  
856

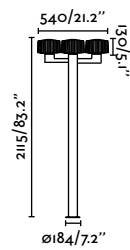
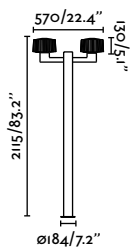

# Muffin

**Design** Àlex & Manel Lluscà

A timeless proposal capable of fitting into various outdoor atmospheres.



Muffin 2L 74435F2-04





**Blubs 2L**  
Estudi Ribaudí

IP44



74435F2-03 ● Dark Grey + Opal

<b>Material</b>	<b>Body</b> Aluminium
	<b>Diff</b> Opal PMMA
<b>Light Source</b>	2 E27 max. 15W
<b>Bulb incl.</b>	No
<b>Class</b>	I

**Blubs 3L**  
Estudi Ribaudí

IP44



74436F3-03 ● Dark Grey + Opal

<b>Material</b>	<b>Body</b> Aluminium
	<b>Diff</b> Opal PMMA
<b>Light Source</b>	3 E27 max. 15W
<b>Bulb incl.</b>	No
<b>Class</b>	I

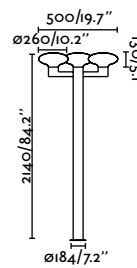
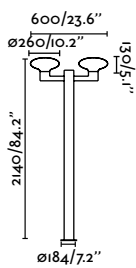
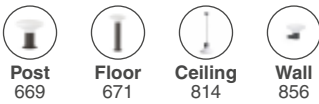

# Blubs

**Design** Estudi Ribaudí



Blub's is like a bubble of air emanating from the earth. Its shapes are softened by the light and complement the space in a simple and ordered way.

Blubs 2L 74435F2-03

## Nautica 1L

IP33



71116

● Rust Brown

## Nautica 2L

IP33



71117

● Rust Brown

## Nautica 3L

IP33



71118

● Rust Brown

<b>Material</b>	<b>Body Steel</b>
	<b>Diff Transparent Glass</b>
<b>Light Source</b>	1 E27 max. 15W
<b>Bulb incl.</b>	No
<b>Class</b>	I

<b>Material</b>	<b>Body Steel</b>
	<b>Diff Transparent Glass</b>
<b>Light Source</b>	2 E27 max. 15W
<b>Bulb incl.</b>	No
<b>Class</b>	I

<b>Material</b>	<b>Body Steel</b>
	<b>Diff Transparent Glass</b>
<b>Light Source</b>	3 E27 max. 15W
<b>Bulb incl.</b>	No
<b>Class</b>	I



Ceiling  
816



Wall  
862

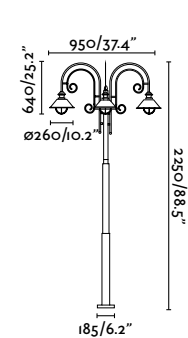
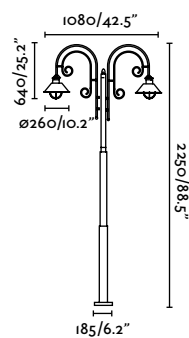
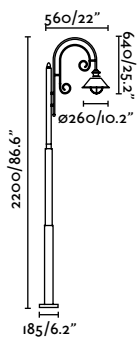



Nautica 1L 71116





Clap estaca 630 c/ pantalla 24V 75708-233P



# PROJECTORS & SPIKES

# Puk

NEW

PUK is the optimal solution for outdoor lighting that combines aesthetics and technology perfectly. Specially designed for architectural spaces, it is distinguished by its recessed light source, guaranteeing high visual comfort.



**Puk**  
4W



ø36

---

**FINISH**

● **Black**

---

**COLOR TEMPERATURE**

2700K CRI80

3000K CRI80

---

**BEAM ANGLE**

8°

20°

40°

---

**ACCESSORIES**



Honeycomb



Visor



Spike



Tree fixing

# Highlights



Goniometer built-into the luminaire arm for more precise aiming of the floodlight at the desired angle.

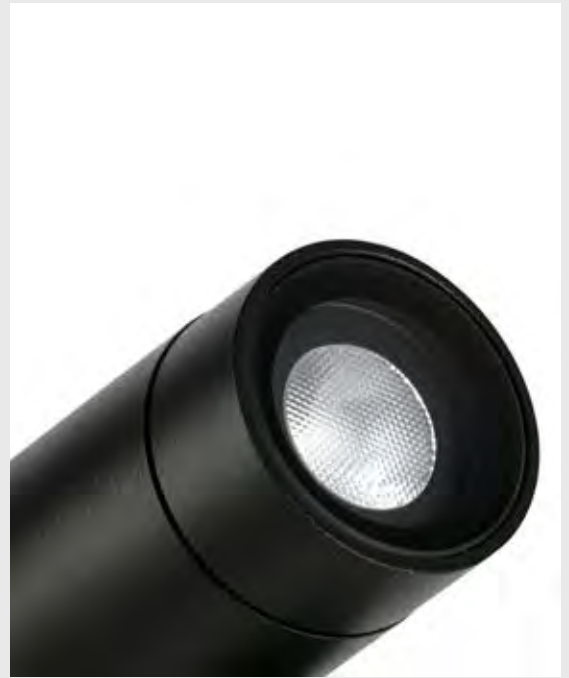

Recessed light source, optics available in 3 different aperture angles.



# Accessories



Optional visor to optimize glare control.



Optional honeycomb accessory, to reduce glare.



Use PUK projectors on the ground by adding the spike accessory.



Puk tree accessory adapts this versatile projector series for tree use. Adjustable straps avoid damaging the tree branches as they grow.



# Puk 36

IP65 IK06 no incl. SEA SIDE SUITABLE 170° 90°

<b>Material</b>	Body Aluminium
	Diff Transparent Glass
<b>Power</b>	4W
<b>Light Source</b>	COB LED
<b>Class</b>	III
<b>CRI</b>	>80
<b>Voltage (V/Hz)</b>	24V DC

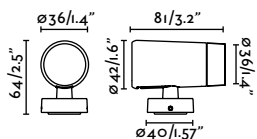

\*Drivers info pag. 1405



Family	Finish	Color T°	Beam Angle						
<b>75300-</b> Puk Projector ø36 2700K	<b>2</b> Black	<b>2</b> 2700K	<table border="1"> <tr><td><b>1</b></td><td>8°</td></tr> <tr><td><b>2</b></td><td>20°</td></tr> <tr><td><b>3</b></td><td>40°</td></tr> </table>	<b>1</b>	8°	<b>2</b>	20°	<b>3</b>	40°
<b>1</b>	8°								
<b>2</b>	20°								
<b>3</b>	40°								
<b>75301-</b> Puk Projector ø36 3000K	<b>2</b> Black	<b>3</b> 3000K	<table border="1"> <tr><td><b>1</b></td><td>8°</td></tr> <tr><td><b>2</b></td><td>20°</td></tr> <tr><td><b>3</b></td><td>40°</td></tr> </table>	<b>1</b>	8°	<b>2</b>	20°	<b>3</b>	40°
<b>1</b>	8°								
<b>2</b>	20°								
<b>3</b>	40°								

Example: 75300-222 Puk Ø36 black 2700K 20°

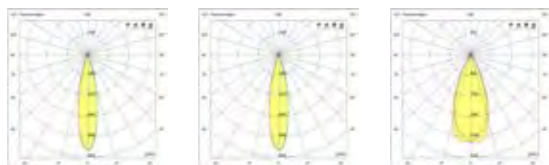

8°

20°

40°

Option	Color T°	CRI	Power	Lumen Output	Beam Angle
75300	2700K	80	4W	326lm / 351lm / 340lm	8° / 20° / 40°
75301	3000K			336lm / 362lm / 351lm	8° / 20° / 40°

# Accessories



## Honeycomb

75300H

● Black

Material

Body Aluminium



$\varnothing 26/1''$



## Tree Fixing

75300F

● Black

Material

Body Aluminium



$80/3.1''$

$60/2.3''$



## Visor

75300V

● Black

Material

Body Aluminium



$\varnothing 68/2.7''$

$82/3.2''$



## Spike

75300S

● Black

Material

Body Polyamide



$\varnothing 38/1.5''$

$170/6.7''$

**Clap proyector árbol 24V**  
Faro Lab

IP65 no incl. 355° 360°



Visor accessory

75703-233 ● Black

<b>Material</b>	Body Aluminium
<b>Power</b>	6W
<b>Lumen Output</b>	524lm
<b>Light Source</b>	COB LED 3000K
<b>Class</b>	III
<b>CRI</b>	>80
<b>Voltage (V/Hz)</b>	24V DC
<b>Beam angle</b>	38°
<b>Recom. Driver</b>	98324026
<b>Cable</b>	2 MT

\*Drivers info pag. 1405

**Visor accessory**

75714-2 ● Black

<b>Material</b>	Body PC
-----------------	---------

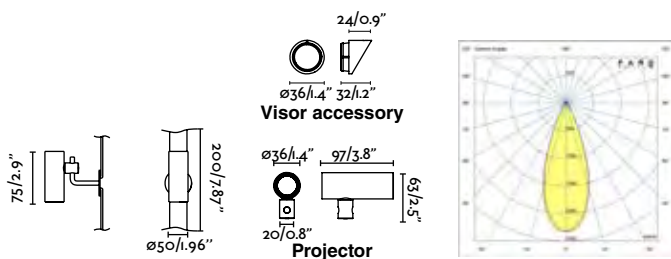

# Clap

NEW

Design Faro Lab

The CLAP tree-mount projector, with its almost invisible structure and volume, emphasizes accent lighting, making it ideal for creating spaces with a theatrical ambiance.









# Muur



Muur 250 71771-110

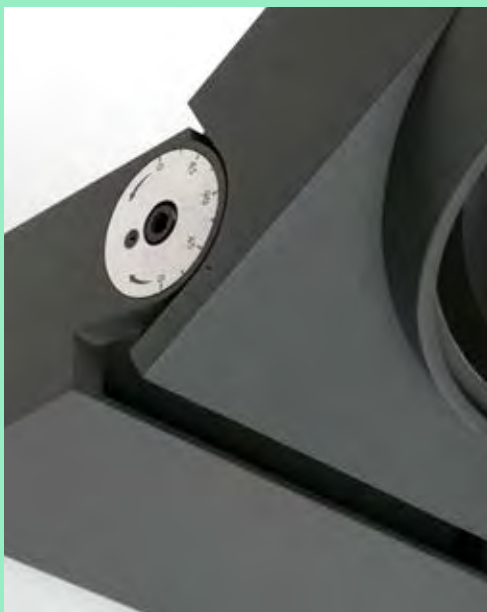

Goniometer

Visor accessory



## Muur 210

IP65 IK06 incl. SEA SIDE SUITABLE 30° 10



Visor accessory

71770-110 ● Dark Grey

<b>Material</b>	<b>Body</b> Aluminium
	<b>Diff</b> Transparent Glass
<b>Power</b>	21W
<b>Lumen Output</b>	1337lm
<b>Light Source</b>	SMD LED 3000K
<b>Class</b>	I
<b>CRI</b>	>80
<b>Voltage (V/Hz)</b>	110V/50-60Hz
<b>Beam angle</b>	36°

### Visor accessory

71770V ● Dark Grey

**Material** **Body** Aluminium

## Muur 250

IP65 IK06 incl. SEA SIDE SUITABLE 30° 10



Visor accessory

71771-110 ● Dark Grey

<b>Material</b>	<b>Body</b> Aluminium
	<b>Diff</b> Transparent Glass
<b>Power</b>	28,5W
<b>Lumen Output</b>	1877lm
<b>Light Source</b>	SMD LED 3000K
<b>Class</b>	I
<b>CRI</b>	>80
<b>Voltage (V/Hz)</b>	110V/50-60Hz
<b>Beam angle</b>	36°

### Visor accessory

71771V ● Dark Grey

**Material** **Body** Aluminium

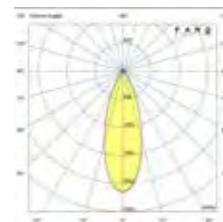
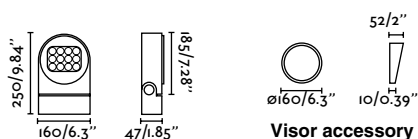
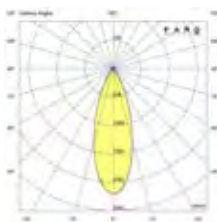
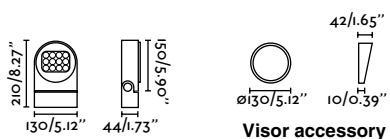



outdoor

Projectors & Spikes



Muir 210-71770-110 + 71770V

745



**Project 73**  
Àlex & Manel Llusçà



- 71383  Grey
- 71390  Dark Grey

<b>Material</b>	<b>Body Aluminium</b>
	<b>Diff Transparent Glass</b>
<b>Light Source</b>	1 GU10 max. 5W
<b>Bulb incl.</b>	No
<b>Class</b>	I

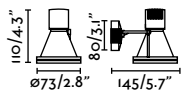

**Project 165**  
Àlex & Manel Llusçà

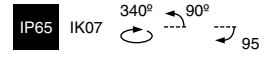

- 71389  Dark Grey

<b>Material</b>	<b>Body Aluminium</b>
	<b>Diff Transparent Glass</b>
<b>Light Source</b>	1 E27 PAR38 max. 15W
<b>Bulb incl.</b>	No
<b>Class</b>	I

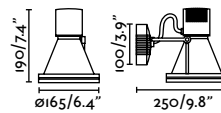

# Project

**Design** Àlex & Manel Llusçà



Projector made of injected aluminium with a protection IP65. A robust and compact design for a highly functional piece.



Project 165 71389



**Alfa**  
Àlex & Manel Llusçà

IP65  incl.



70025-110 ● Dark Grey

<b>Material</b>	<b>Body</b> Aluminium <b>Diff</b> Transparent Glass
<b>Power</b>	13W
<b>Lumen Output</b>	845lm
<b>Light Source</b>	COB LED 3000K
<b>Class</b>	I
<b>CRI</b>	>80
<b>Voltage (V/Hz)</b>	110V/50-60Hz
<b>Beam angle</b>	80°

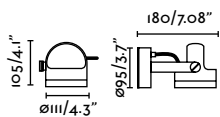

# Alfa

**Design** Àlex & Manel Lluscà

Projector made of injected aluminium with a decorative and technical aesthetics.

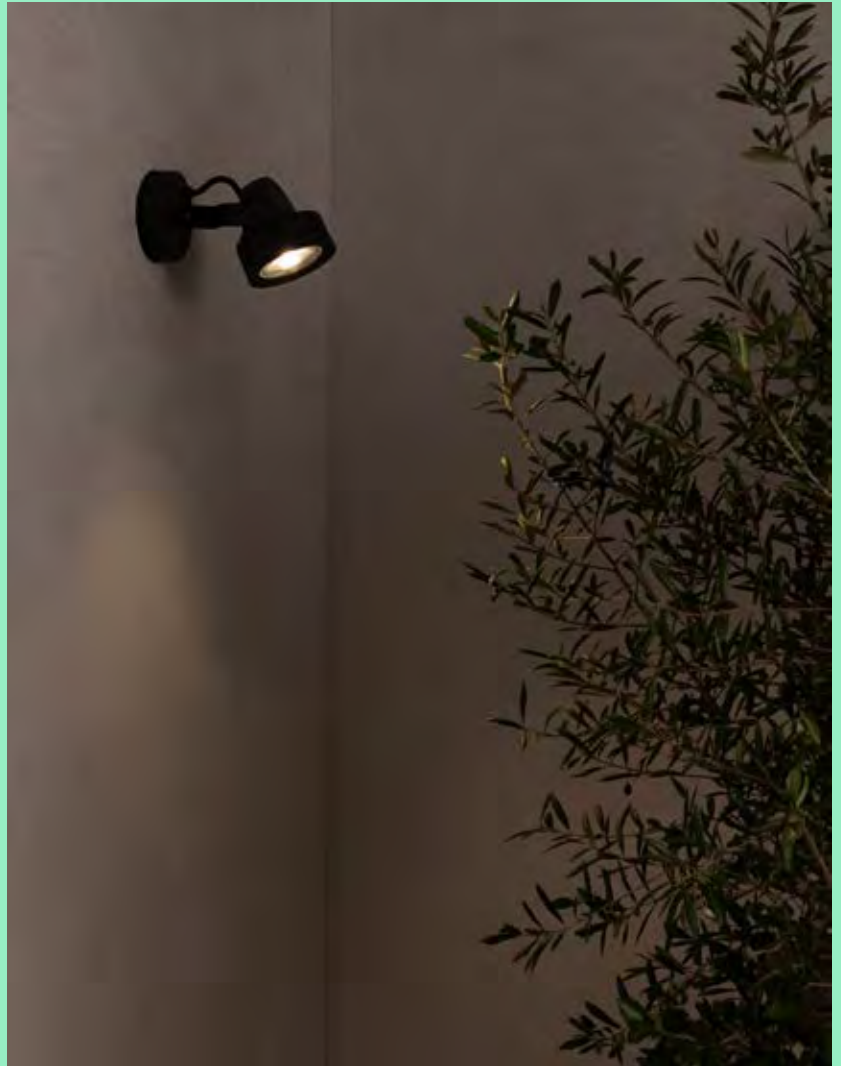

It can be oriented and it is ideal to illuminate entrances in gardens and terraces focusing the light where it is needed.

## Plom

IP64 incl. 90°



70912 ● Dark Grey

<b>Material</b>	Body Aluminium Diff PMMA
<b>Power</b>	8,5W
<b>Lumen Output</b>	635lm
<b>Light Source</b>	COB LED 3000K
<b>Class</b>	I
<b>CRI</b>	>80
<b>Voltage (V/Hz)</b>	100V-240V/50-60Hz
<b>Beam angle</b>	18-45°

## Lit

IP54 IK06 45°



70260 ● Dark Grey

<b>Material</b>	Body Aluminium Diff Transparent Glass
<b>Light Source</b>	1 GU10 max. 8W
<b>Bulb incl.</b>	No
<b>Class</b>	I



Spike  
790

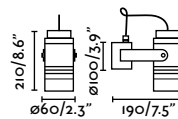
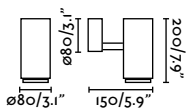
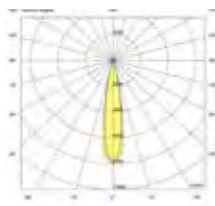
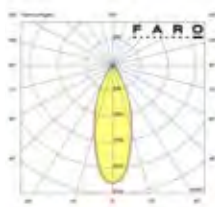

# Plom & Lit

outdoor

Projectors & Spikes



Plom 70912



Lit 70260

**Flow**  
Alegre Design

IP65 IK07 360° 160° 180°



- 71546 ● Matt Black
- 71547 ● Beige

<b>Material</b>	<b>Body</b> PC+Aluminium
	<b>Diff</b> Opal PC
<b>Light Source</b>	1 GU10 max. 5W
<b>Bulb incl.</b>	No
<b>Class</b>	II
<b>Cable</b>	2.5 MT

Spike accessory 60cm	
71548	● Matt Black
71549	● Beige

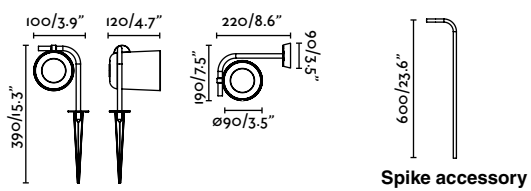



# Flow

Design Alegre Design

A spike of timeless and fun design that fits organically into all types of outdoor spaces.



You can nail it directly to the ground or to the wall with an accessory that makes it a surface luminaire.

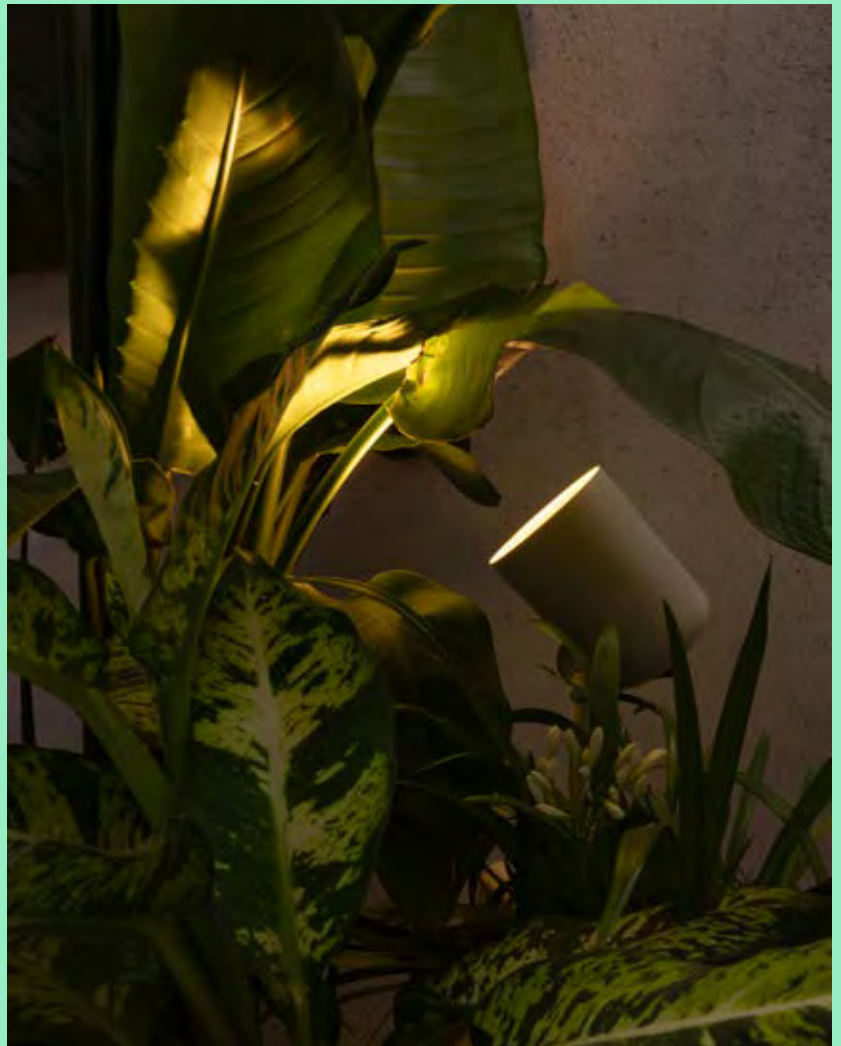

Flow 71547



Flow 71546  
+ Spike accessory  
60cm 71548

# Slot

Design Lucid Product Design



Visor accessory  
70039



Slot 500 70036

outdoor

Projectors & Spikes

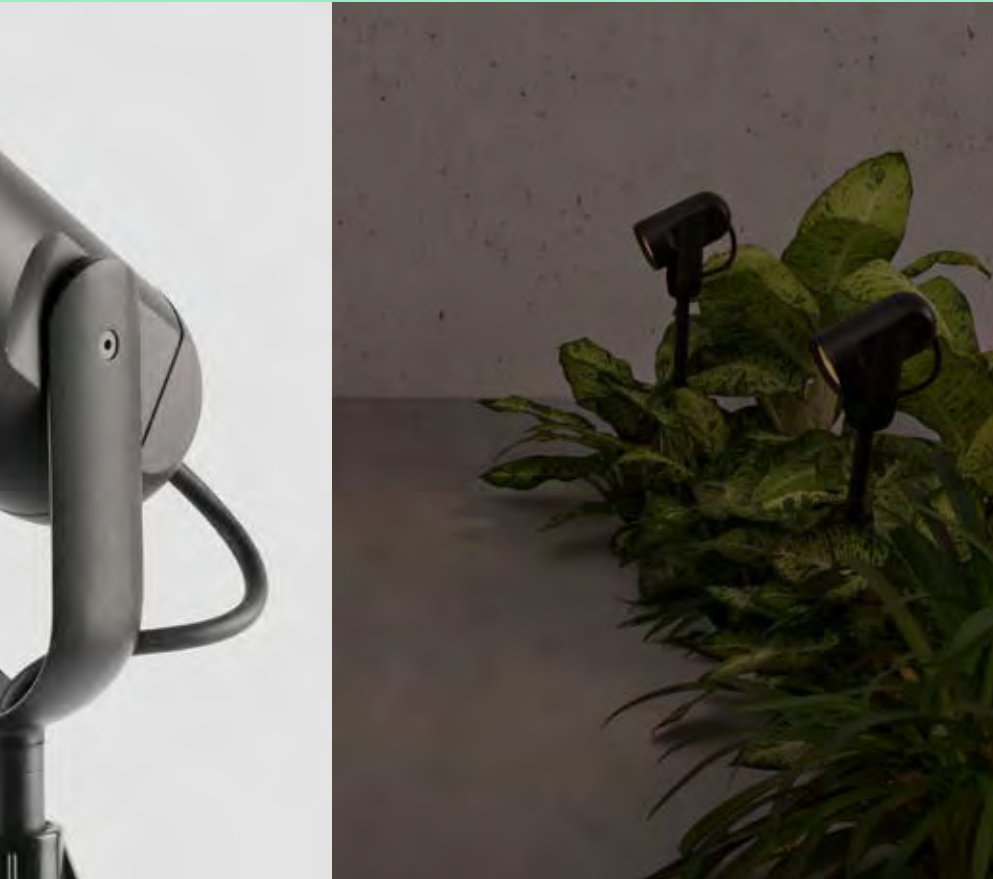

Slot 500  
spike 70038

Slot 200  
spike 70037

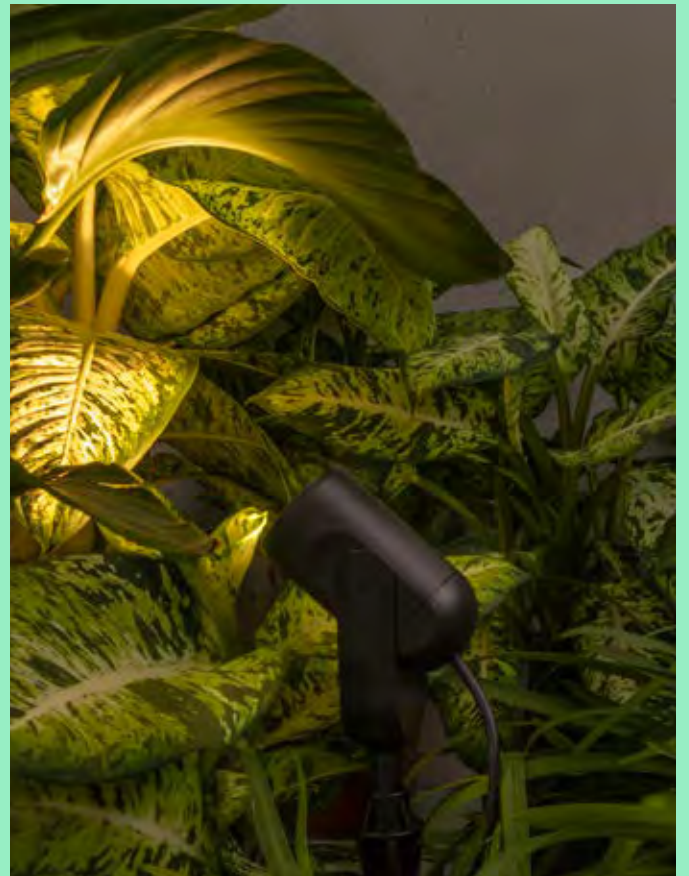

**Slot 200**  
Lucid Product Design

IP65 IK08 incl.



Visor accessory

70035 ● Black

<b>Material</b>	Body Aluminium
	Diff Transparent Glass
<b>Power</b>	13W
<b>Lumen Output</b>	750lm
<b>Light Source</b>	COB LED 3000K
<b>Class</b>	I
<b>CRI</b>	>80
<b>Voltage (V/Hz)</b>	100V-240V/50-60Hz
<b>Beam angle</b>	28°

Visor accessory	
70039	● Black
<b>Material</b>	Body Aluminium

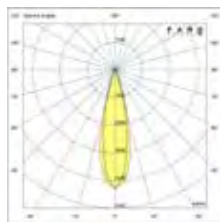
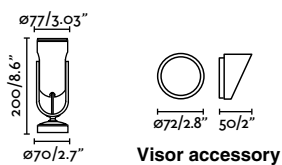

**Slot 500**  
Lucid Product Design

IP65 IK08 incl.



Visor accessory

70036 ● Black

<b>Material</b>	Body Aluminium
	Diff Transparent Glass
<b>Power</b>	13W
<b>Lumen Output</b>	750lm
<b>Light Source</b>	COB LED 3000K
<b>Class</b>	I
<b>CRI</b>	>80
<b>Voltage (V/Hz)</b>	100V-240V/50-60Hz
<b>Beam angle</b>	28°

Visor accessory	
70039	● Black
<b>Material</b>	Body Aluminium

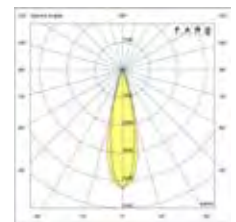
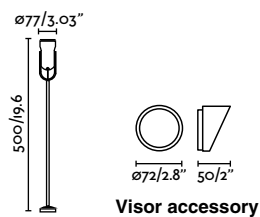



outdoor

Projectors & Spikes





**Slot 200 spike**  
Lucid Product Design

IP65 IK08 incl.



Visor accessory

70037 ● Black

<b>Material</b>	<b>Body Aluminium</b>
	<b>Diff Transparent Glass</b>
<b>Power</b>	13W
<b>Lumen Output</b>	750lm
<b>Light Source</b>	COB LED 3000K
<b>Class</b>	I
<b>CRI</b>	>80
<b>Voltage (V/Hz)</b>	100V-240V/50-60Hz
<b>Beam angle</b>	28°
<b>Cable</b>	1.5 MT

<b>Visor accessory</b>	
70039	● Black
<b>Material</b>	<b>Body Aluminium</b>

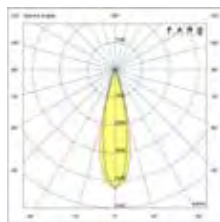
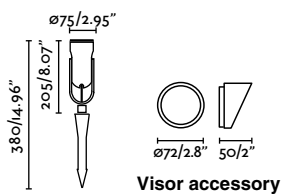

**Slot 500 spike**  
Lucid Product Design

IP65 IK08 incl.



Visor accessory

70038 ● Black

<b>Material</b>	<b>Body Aluminium</b>
	<b>Diff Transparent Glass</b>
<b>Power</b>	13W
<b>Lumen Output</b>	750lm
<b>Light Source</b>	COB LED 3000K
<b>Class</b>	I
<b>CRI</b>	>80
<b>Voltage (V/Hz)</b>	100V-240V/50-60Hz
<b>Beam angle</b>	28°
<b>Cable</b>	1.5 MT

<b>Visor accessory</b>	
70039	● Black
<b>Material</b>	<b>Body Aluminium</b>

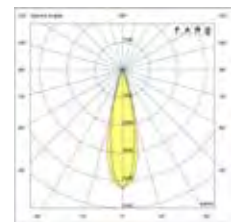
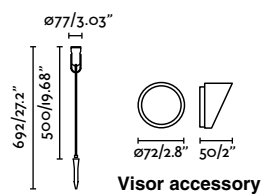



outdoor

Projectors & Spikes



Slot 200 spike 70037

759





Clap estaca 630 c/ pantalla 24V 75708-233P

760

# Clap NEW

**Design** Faro Lab

The Clap spike, with its nearly invisible structure and volume, focuses on accent lighting, making it ideal for creating spaces with a theatrical character amidst vegetation.



Clap estaca 630 c/ pantalla 24V 75708-233P

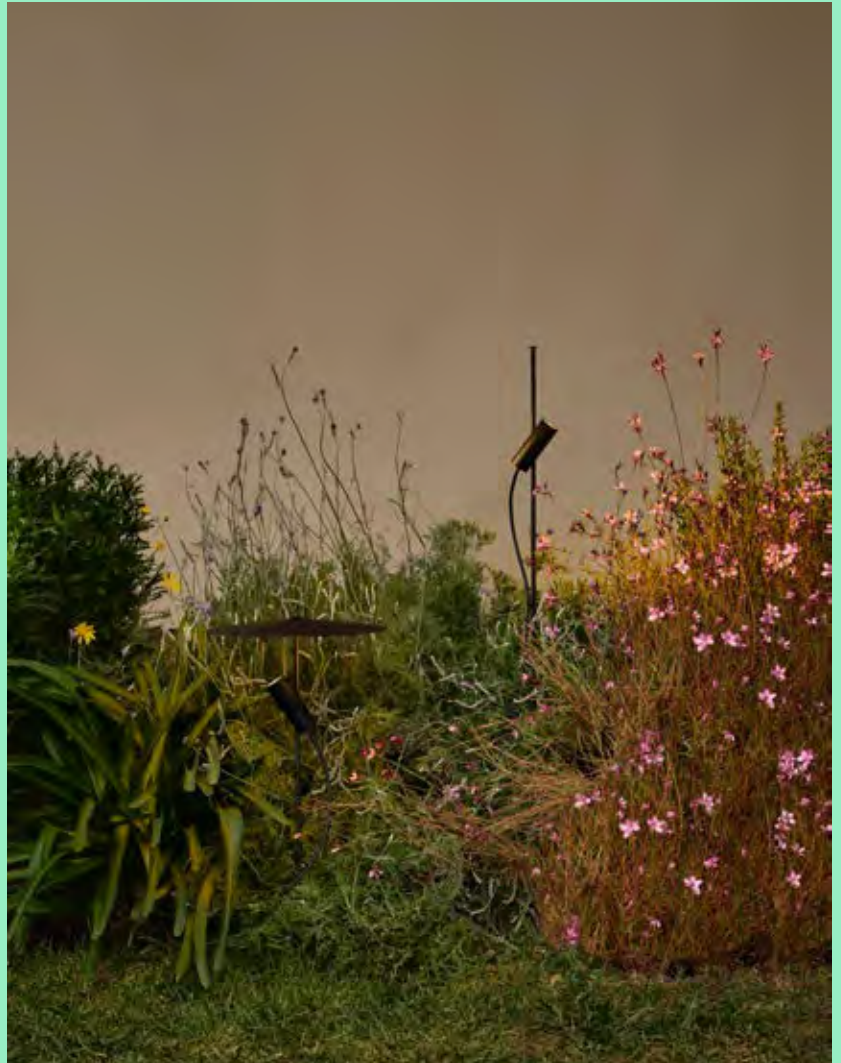









**Clap estaca 630 24V**  
Faro Lab

IP65 no incl. 355° 360°

24V DC



Visor accessory

75708-233 ● Black

<b>Material</b>	Body Aluminium
<b>Power</b>	6W
<b>Lumen Output</b>	524lm
<b>Light Source</b>	COB LED 3000K
<b>Class</b>	II
<b>CRI</b>	>80
<b>Voltage (V/Hz)</b>	24V DC
<b>Beam angle</b>	38°
<b>Recom. Driver</b>	98324026
<b>Cable</b>	2 MT

\*Drivers info pag. 1405

**Visor accessory**

75714-2 ● Black

**Material** Body PC

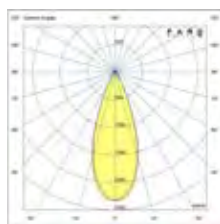
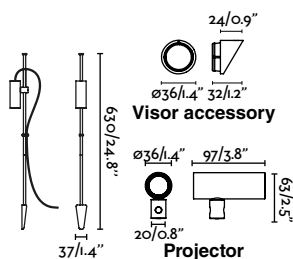
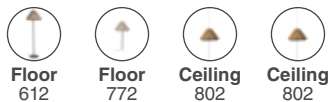

**Clap estaca 1030 24V**  
Faro Lab

IP65 no incl. 355° 360°

24V DC



Visor accessory

75709-233 ● Black

<b>Material</b>	Body Aluminium+Stainless steel
<b>Power</b>	2X6W
<b>Lumen Output</b>	2x524lm
<b>Light Source</b>	COB LED 3000K
<b>Class</b>	III
<b>CRI</b>	>80
<b>Voltage (V/Hz)</b>	24V DC
<b>Beam angle</b>	38°
<b>Recom. Driver</b>	98324026
<b>Cable</b>	2 MT

\*Drivers info pag. 1405

**Visor accessory**

75714-2 ● Black

**Material** Body PC

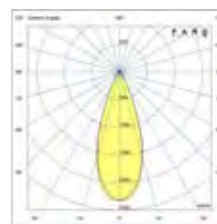
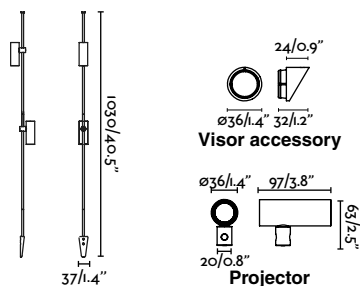

**Clap estaca 630 c/ pantalla 24V**  
Faro Lab

IP65 no incl. 355° 360°

24V DC



Visor accessory

75708-233P ● Black

<b>Material</b>	<b>Body</b> Aluminium
	<b>Shade</b> Aluminium
<b>Power</b>	6W
<b>Lumen Output</b>	524lm
<b>Light Source</b>	COB LED 3000K
<b>Class</b>	III
<b>CRI</b>	>80
<b>Voltage (V/Hz)</b>	24V DC
<b>Beam angle</b>	38°
<b>Recom. Driver</b>	98324026
<b>Cable</b>	2 MT

\*Drivers info pag. 1405

**Visor accessory**

75714-2 ● Black

**Material** Body PC

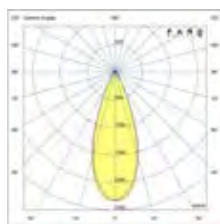
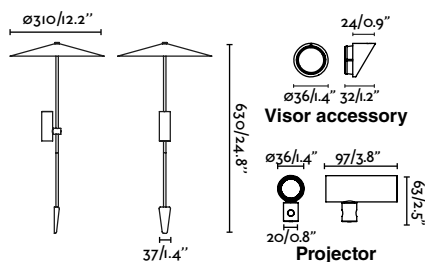

Projectors' photometric curve

**Clap estaca 1030 c/ pantalla 24V**  
Faro Lab

IP65 no incl. 355° 360°

24V DC



Visor accessory

75709-233P ● Black

<b>Material</b>	<b>Body</b> Aluminium+Stainless steel
	<b>Shade</b> Aluminium
<b>Power</b>	2X6W
<b>Lumen Output</b>	2x524lm
<b>Light Source</b>	COB LED 3000K
<b>Class</b>	III
<b>CRI</b>	>80
<b>Voltage (V/Hz)</b>	24V DC
<b>Beam angle</b>	38°
<b>Recom. Driver</b>	98324026
<b>Cable</b>	2 MT

\*Drivers info pag. 1405

**Visor accessory**

75714-2 ● Black

**Material** Body PC

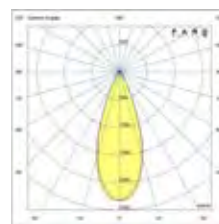
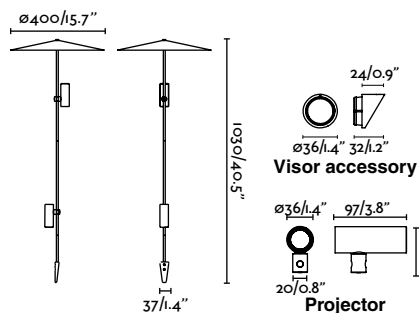

Projectors' photometric curve



Cuca   
Design Faro Lab

Its minimalist stainless steel structure in the shape of a semicircular arch raises and moves a small ball of light generating elegant and minimalist scenographic spaces.









**Cuca 650 24V**  
Faro Lab

IP65 IK06  no incl.

24V DC



75561 ● Black

<b>Material</b>	<b>Body</b> Stainless steel
	<b>Diff</b> Opal Glass
<b>Power</b>	3W
<b>Lumen Output</b>	154lm
<b>Light Source</b>	COB LED 2700K
<b>Class</b>	III
<b>CRI</b>	>90
<b>Voltage (V/Hz)</b>	24V DC
<b>Cable</b>	0.5 MT

\*Drivers info pag. 1405

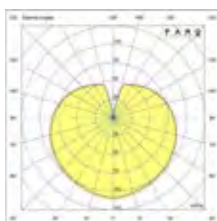
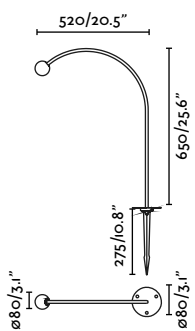
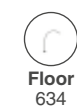

**Cuca 1193 24V**  
Faro Lab

IP65 IK06  no incl.

24V DC



75562 ● Black

<b>Material</b>	<b>Body</b> Stainless steel
	<b>Diff</b> Opal Glass
<b>Power</b>	3W
<b>Lumen Output</b>	154lm
<b>Light Source</b>	COB LED 2700K
<b>Class</b>	III
<b>CRI</b>	>90
<b>Voltage (V/Hz)</b>	24V DC
<b>Cable</b>	0.5 MT

\*Drivers info pag. 1405

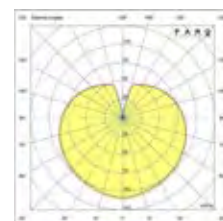
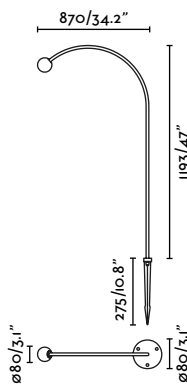





# Saigon

**Design** Nahtrang

It is characterized by  
simplicity and pure forms.

Saigon out W70  
71575P-07



Saigon out C70 71575P-09

outdoor

Projectors & Spikes



Saigon out 1150 R55  
71575-01



771

**Saigon out C70**  
Nahtrang

IP44

NEW MATERIAL



- 71575P-09 ● Dark Grey + Beige
- 71575P-11 ● Dark Grey + Green
- 71575-13 ● Dark Grey + Ochre

<b>Material</b>	<b>Body</b> Aluminium
	<b>Diff</b> Opal PEMD
	<b>Shade</b> PP
<b>Light Source</b>	1 E27 max. 15W
<b>Bulb incl.</b>	No
<b>Class</b>	II
<b>Cable</b>	2 MT

**Saigon out W70**  
Nahtrang

IP44



- 71575P-07 ● Dark Grey + Brown

<b>Material</b>	<b>Body</b> Aluminium
	<b>Diff</b> Opal PEMD
	<b>Shade</b> Synthetic wicker
<b>Light Source</b>	1 E27 max. 15W
<b>Bulb incl.</b>	No
<b>Class</b>	II
<b>Cable</b>	2 MT

**Saigon out T70**  
Nahtrang

IP44



- 71575P-05 ● Dark Grey + Cream
- 71575P-06 ● Dark Grey + Brown

<b>Material</b>	<b>Body</b> Aluminium
	<b>Diff</b> Opal PEMD
	<b>Shade</b> Textilene
<b>Light Source</b>	1 E27 max. 15W
<b>Bulb incl.</b>	No
<b>Class</b>	II
<b>Cable</b>	2 MT

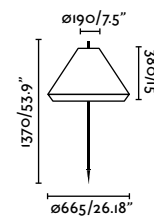
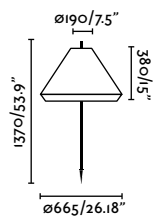
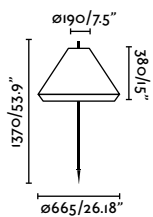
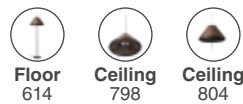





**Saigon out 870 R45**  
Nahtrang

IP44



71576P-04 ●● Dark Grey + White

<b>Material</b>	<b>Body</b> Aluminium
	<b>Shade</b> PEMD
<b>Light Source</b>	1 E27 max. 15W
<b>Bulb incl.</b>	No
<b>Class</b>	II
<b>Cable</b>	2 MT

**Saigon out 1500 R45**  
Nahtrang

IP44



71575P-04 ●● Dark Grey + White

<b>Material</b>	<b>Body</b> Aluminium
	<b>Shade</b> PEMD
<b>Light Source</b>	1 E27 max. 15W
<b>Bulb incl.</b>	No
<b>Class</b>	II
<b>Cable</b>	2 MT



**Floor**  
620



**Suspended**  
800



**Ceiling**  
806

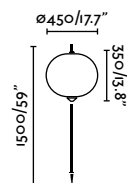
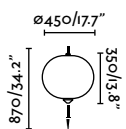





**Saigon out 1350 R55**  
Nahtrang

IP44



71575P-01 ● Dark Grey + White

**Saigon out 730 R17**  
Nahtrang

IP44



71576P-03 ● Dark Grey + White

**Saigon out 1370 R17**  
Nahtrang

IP44



71575P-03 ● Dark Grey + White

<b>Material</b>	<b>Body Aluminium</b>
	<b>Shade PEMD</b>
<b>Light Source</b>	1 E27 max. 15W
<b>Bulb incl.</b>	No
<b>Class</b>	II
<b>Cable</b>	2 MT

<b>Material</b>	<b>Body Aluminium</b>
	<b>Shade PEMD</b>
<b>Light Source</b>	1 E27 max. 15W
<b>Bulb incl.</b>	No
<b>Class</b>	II
<b>Cable</b>	2 MT

<b>Material</b>	<b>Body Aluminium</b>
	<b>Shade PEMD</b>
<b>Light Source</b>	1 E27 max. 15W
<b>Bulb incl.</b>	No
<b>Class</b>	II
<b>Cable</b>	2 MT

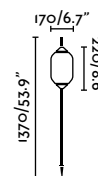
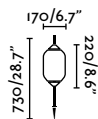
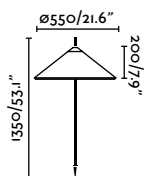
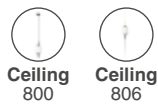
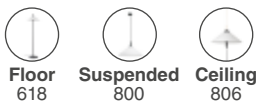







**Piccola**  
Faro Lab

IP65 IK08 incl.



- 70245 ● Matt Black
- 70246 ● Matt White

<b>Material</b>	<b>Body</b> Aluminium
	<b>Diff</b> Opal PMMA
<b>Power</b>	6W
<b>Lumen Output</b>	360lm
<b>Light Source</b>	SMD LED 2700K
<b>Class</b>	I
<b>CRI</b>	>80
<b>Voltage (V/Hz)</b>	100V-240V/50-60Hz
<b>Cable</b>	1.5 MT

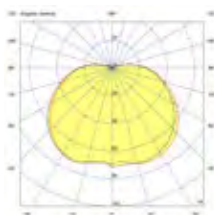
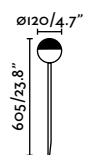

# Piccola

**Design** Faro Lab

Piccola is an easy to install outdoor light point as it incorporates a large cable. Its translucent diffuser is covered in its upper part to avoid glare and guarantee comfort.

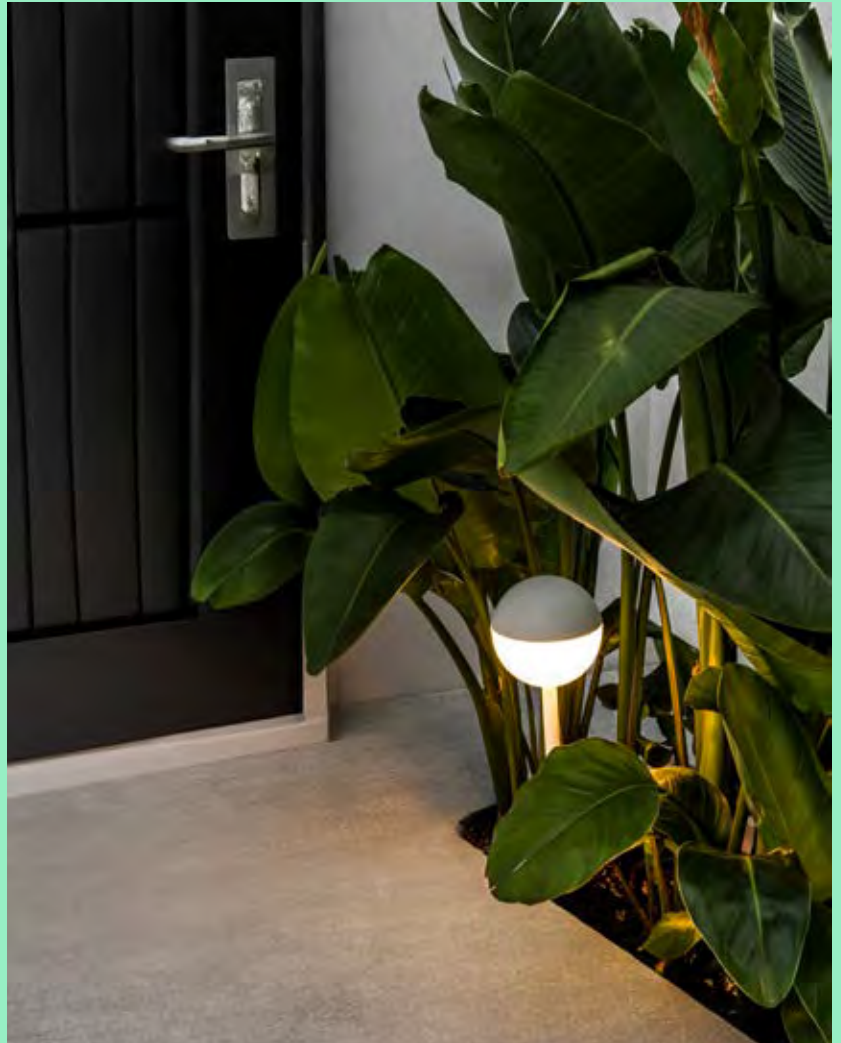

Piccola 70246



Piccola 70245

**Toni**  
Alegre Design

IP65 IK07 SEA SIDE SUITABLE 90



71528 ● Matt Black

<b>Material</b>	<b>Body PC</b>
	<b>Diff Transparent PC</b>
<b>Light Source</b>	1 GU10 max. 5W
<b>Bulb incl.</b>	No
<b>Class</b>	II
<b>Cable</b>	2.5 MT

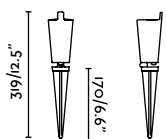



# Toni

Design Alegre Design

Toni is a corrosion-proof orientable projector stake and can be installed directly on the ground thanks to the stake included or as a wall luminaire with its surface accessory.



## Bambou 1068

IP65 IK06 incl. CONNECTOR



75556-110 ● Matt Black

<b>Material</b>	Body Aluminium
	Diff Transparent Glass
<b>Power</b>	8W
<b>Lumen Output</b>	606lm
<b>Light Source</b>	MODULO LED 2700K
<b>Class</b>	I
<b>CRI</b>	>=80
<b>Voltage (V/Hz)</b>	110V/50-60Hz
<b>Beam angle</b>	360°
<b>Cable</b>	0.2 MT

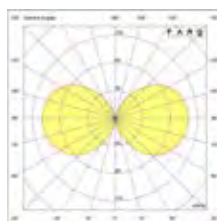
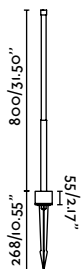

## Bambou 1268

IP65 IK06 incl. CONNECTOR



75557-110 ● Matt Black

<b>Material</b>	Body Aluminium
	Diff Transparent Glass
<b>Power</b>	8W
<b>Lumen Output</b>	606lm
<b>Light Source</b>	MODULO LED 2700K
<b>Class</b>	I
<b>CRI</b>	>=80
<b>Voltage (V/Hz)</b>	110V/50-60Hz
<b>Beam angle</b>	360°
<b>Cable</b>	0.2 MT

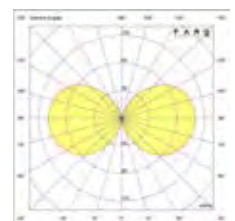
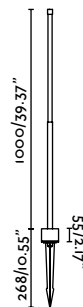



**Bezel**  
Faro Lab

IP65 IK06 incl. IP68 CONNECTOR



70248-110 ● Matt Black

	Diff Transparent Glass
<b>Power</b>	8W
<b>Lumen Output</b>	349lm
<b>Light Source</b>	COB LED 2700K
<b>CRI</b>	90
<b>Voltage (V/Hz)</b>	110V/50-60Hz
<b>Cable</b>	1.2 MT

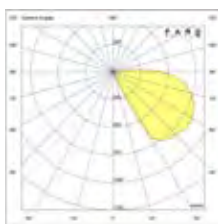
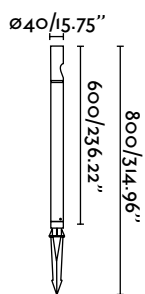







## Seth 280

IP44 IK06 incl.



70227

● Matt Black

<b>Material</b>	Body Aluminium Diff Transparent PMMA
<b>Power</b>	6W
<b>Lumen Output</b>	450lm
<b>Light Source</b>	SMD LED 2700K
<b>Class</b>	II
<b>CRI</b>	>80
<b>Voltage (V/Hz)</b>	100V-240V/50-60Hz
<b>Beam angle</b>	40°
<b>Cable</b>	2 MT

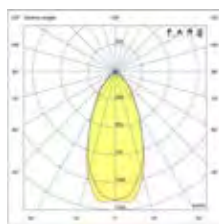
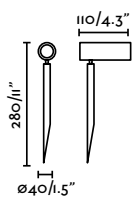

## Seth 600

IP44 IK06 incl.



70226

● Matt Black

<b>Material</b>	Body Aluminium Diff Transparent PMMA
<b>Power</b>	6W
<b>Lumen Output</b>	450lm
<b>Light Source</b>	SMD LED 2700K
<b>Class</b>	II
<b>CRI</b>	>80
<b>Voltage (V/Hz)</b>	100V-240V/50-60Hz
<b>Beam angle</b>	40°
<b>Cable</b>	2 MT

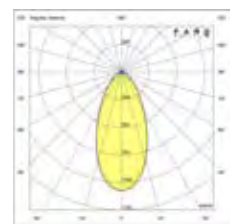
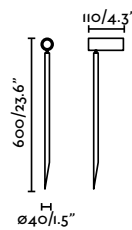



Seth 600 70226

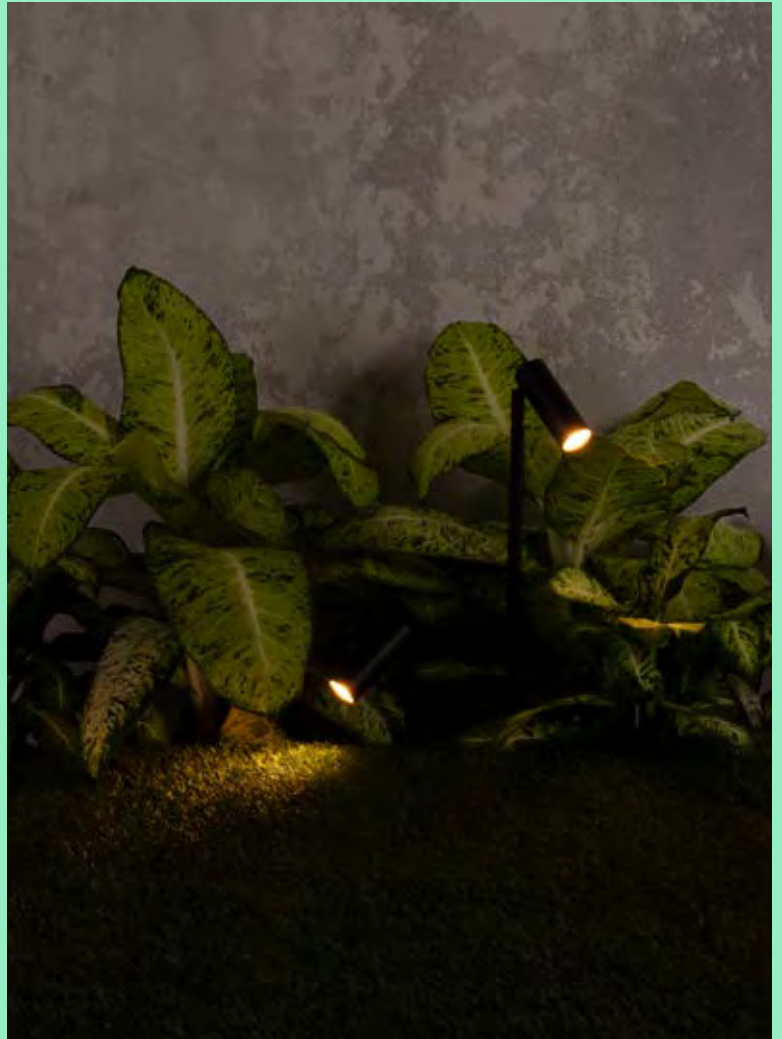

Seth 280 70227

Sobek

IP65 IK06 incl.



70151

● Dark Grey

<b>Material</b>	<b>Body</b> Aluminium
	<b>Diff</b> Transparent Glass
<b>Power</b>	7W
<b>Lumen Output</b>	550lm
<b>Light Source</b>	COB LED 3000K
<b>Class</b>	I
<b>CRI</b>	>80
<b>Voltage (V/Hz)</b>	100V-240V/50-60Hz
<b>Beam angle</b>	50°
<b>Cable</b>	2 MT

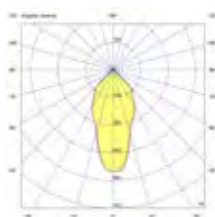
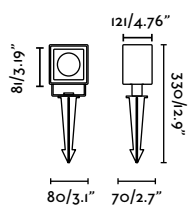

788







## Andy

IP65



71613

● Satin Gold

<b>Material</b>	<b>Body Steel</b>
	<b>Diff Transparent PC</b>
<b>Light Source</b>	1 GU10 max. 5W
<b>Bulb incl.</b>	No
<b>Class</b>	I
<b>Cable</b>	2 MT

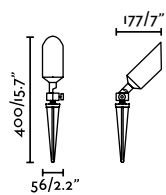

## Plom

IP64

incl. ↻ 90



70913

● Dark Grey

<b>Material</b>	<b>Body Aluminium</b>
	<b>Diff Transparent PMMA</b>
<b>Power</b>	8,5W
<b>Lumen Output</b>	635lm
<b>Light Source</b>	COB LED 3000K
<b>Dimmable W</b>	
<b>Class</b>	I
<b>CRI</b>	>80
<b>Voltage (V/Hz)</b>	100V-240V/50-60Hz
<b>Beam angle</b>	18-45°
<b>Cable</b>	0.3 MT



Wall  
750

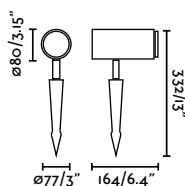



Tono

IP44



73150

● Matt Black

<b>Material</b>	<b>Body</b> Aluminium
	<b>Diff</b> Transparent Glass
<b>Light Source</b>	1 GU10 max. 8W
<b>Bulb incl.</b>	No
<b>Class</b>	I
<b>Cable</b>	2 MT

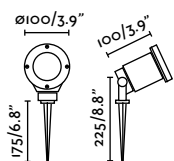

792









# SUSPENDED

# Saigon

**Design** Nahtrang

It is characterized by simplicity and pure forms.

Saigon out W70  
71579C-07



Saigon out C70 71579C-09



outdoor

Suspended



Saigon out C70 71579C-11

Saigon out R55  
71579-02





**Saigon out C70**  
Nahtrang

IP44



- 71579C-09 ● Dark Grey + Beige
- 71579C-11 ● Dark Grey + Green
- 71579C-13 ● Dark Grey + Ochre

<b>Material</b>	<b>Body</b> Aluminium
	<b>Diff</b> Opal PEMD
	<b>Shade</b> PP
<b>Light Source</b>	1 E27 max. 15W
<b>Bulb incl.</b>	No
<b>Class</b>	II
<b>Cable</b>	1.2 MT

**Saigon out W70**  
Nahtrang

IP44



- 71579C-07 ● Dark Grey + Brown

<b>Material</b>	<b>Body</b> Aluminium
	<b>Diff</b> Opal PEMD
	<b>Shade</b> Synthetic wicker
<b>Light Source</b>	1 E27 max. 15W
<b>Bulb incl.</b>	No
<b>Class</b>	II
<b>Cable</b>	1.2 MT

**Saigon out T70**  
Nahtrang

IP44



- 71579C-05 ● Dark Grey + Cream
- 71579C-06 ● Dark Grey + Brown

<b>Material</b>	<b>Body</b> Aluminium
	<b>Diff</b> Opal PEMD
	<b>Shade</b> Textilene
<b>Light Source</b>	1 E27 max. 15W
<b>Bulb incl.</b>	No
<b>Class</b>	II
<b>Cable</b>	1.2 MT

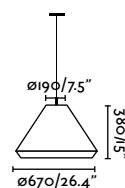
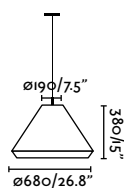
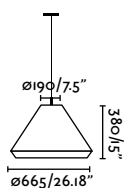
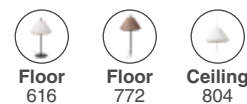
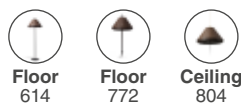
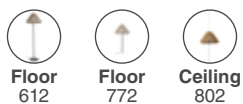

outdoor

Suspended



Saigon out C70 71579C-11

799

**Saigon out R55**  
Nahtrang

IP44



71579-02

● ● Dark Grey + White

**Saigon out R45**  
Nahtrang

IP44 IK06



71579C-04

● ● Dark Grey + White

**Saigon out R17**  
Nahtrang

IP44



71579C-03

● ● Dark Grey + White

<b>Material</b>	<b>Body</b> Aluminium
	<b>Shade</b> PEMD
<b>Light Source</b>	1 E27 max. 15W
<b>Bulb incl.</b>	No
<b>Class</b>	II
<b>Cable</b>	1.2 MT

<b>Material</b>	<b>Body</b> Aluminium
	<b>Shade</b> PEMD
<b>Light Source</b>	1 E27 max. 15W
<b>Bulb incl.</b>	No
<b>Class</b>	II
<b>Cable</b>	1.2 MT

<b>Material</b>	<b>Body</b> Aluminium
	<b>Shade</b> PEMD
<b>Light Source</b>	1 E27 max. 15W
<b>Bulb incl.</b>	No
<b>Class</b>	II
<b>Cable</b>	1.2 MT

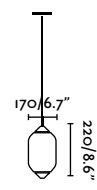
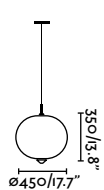
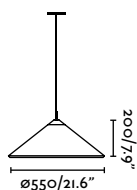
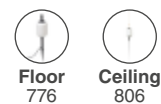
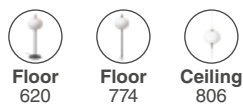
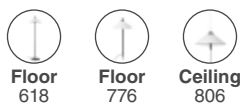



outdoor

Suspended



Saigon out R45 71579C-04

801



**Saigon out C100 portable**  
Nahtrang

IP44 

NEW MATERIAL



- 71584-10  Dark Grey + Beige
- 71584-12  Dark Grey + Green
- 71584-14  Dark Grey + Ochre

<b>Material</b>	<b>Body</b> Aluminium
	<b>Diff</b> Opal PEMD
	<b>Shade</b> PP
<b>Light Source</b>	1 E27 max. 15W
<b>Bulb incl.</b>	No
<b>Class</b>	II
<b>Cable</b>	3 MT

\*Rope not included

**Saigon out C70 portable**  
Nahtrang

IP44 

NEW MATERIAL



- 71584-09  Dark Grey + Beige
- 71584-11  Dark Grey + Green
- 71584-13  Dark Grey + Ochre

<b>Material</b>	<b>Body</b> Aluminium
	<b>Diff</b> Opal PEMD
	<b>Shade</b> PP
<b>Light Source</b>	1 E27 max. 15W
<b>Bulb incl.</b>	No
<b>Class</b>	II
<b>Cable</b>	3 MT

\*Rope not included



Floor  
612



Floor  
612



Floor  
772

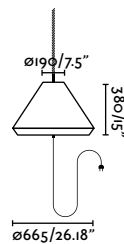
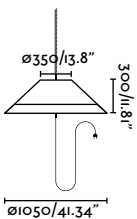



outdoor

Suspended



Saigon out C70 71579C-11

803



**Saigon out W100 portable** IP44   
Nahrang



71584-08  Dark Grey + Brown

<b>Material</b>	<b>Body</b> Aluminium
	<b>Diff</b> Opal PEMD
	<b>Shade</b> Synthetic wicker
<b>Light Source</b>	1 E27 max. 15W
<b>Bulb incl.</b>	No
<b>Class</b>	II
<b>Cable</b>	3 MT

\*Rope not included



Floor  
614

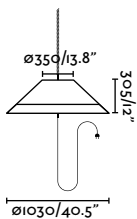

**Saigon out W70 portable** IP44   
Nahrang



71584-07  Dark Grey + Brown

<b>Material</b>	<b>Body</b> Aluminium
	<b>Diff</b> Opal PEMD
	<b>Shade</b> Synthetic wicker
<b>Light Source</b>	1 E27 max. 15W
<b>Bulb incl.</b>	No
<b>Class</b>	II
<b>Cable</b>	3 MT

\*Rope not included



Floor  
614



Ceiling  
798



Floor  
772

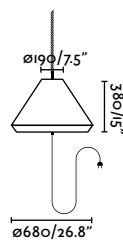

**Saigon out T70 portable** IP44   
Nahrang



71584-05  Dark Grey + Cream

71584-06  Dark Grey + Brown

<b>Material</b>	<b>Body</b> Aluminium
	<b>Diff</b> Opal PEMD
	<b>Shade</b> Textilene
<b>Light Source</b>	1 E27 max. 15W
<b>Bulb incl.</b>	No
<b>Class</b>	II
<b>Cable</b>	3 MT

\*Rope not included



Floor  
616



Ceiling  
798



Floor  
772

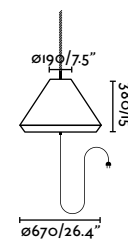

outdoor

Suspended



Saigon out T70 portable  
71584-05



Saigon out W70 portable  
71584-07



**Saigon out R55 portable**  
Nahtrang



**Saigon out R45 portable**  
Nahtrang



**Saigon out R17 portatil**  
Nahtrang



71584-01 ● Dark Grey + White



71584-04 ● Dark Grey + White



71584-03 ● Dark Grey + White

<b>Material</b>	<b>Body</b> Aluminium
	<b>Shade</b> PEMD
<b>Light Source</b>	1 E27 max. 15W
<b>Bulb incl.</b>	No
<b>Class</b>	II
<b>Cable</b>	3 MT

\*Rope not included

<b>Material</b>	<b>Body</b> Aluminium
	<b>Shade</b> PEMD
<b>Light Source</b>	1 E27 max. 15W
<b>Bulb incl.</b>	No
<b>Class</b>	II
<b>Cable</b>	3 MT

\*Rope not included

<b>Material</b>	<b>Body</b> Aluminium
	<b>Shade</b> PEMD
<b>Light Source</b>	1 E27 max. 15W
<b>Bulb incl.</b>	No
<b>Class</b>	II
<b>Cable</b>	3 MT

\*Rope not included

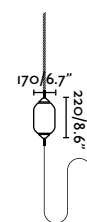
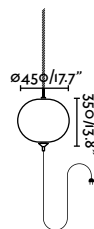
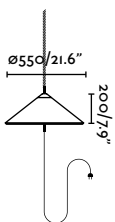
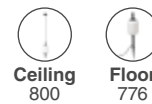
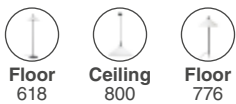

outdoor

Suspended



## Scuba louver 1200

IP65 IK10 incl.

NEW



75758-01-110 ● Black

<b>Material</b>	<b>Body</b> Aluminium
	<b>Diff</b> Transparent PC
<b>Power</b>	36W
<b>Lumen Output</b>	1575lm
<b>Light Source</b>	SMD LED 2700K
<b>Class</b>	I
<b>CRI</b>	>90
<b>Voltage (V/Hz)</b>	100V-240V/50-60Hz
<b>Beam angle</b>	80x130°
<b>Cable</b>	3 MT
<b>Accessories</b>	Tensor included

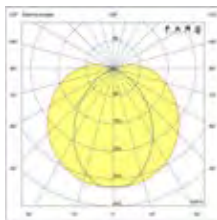
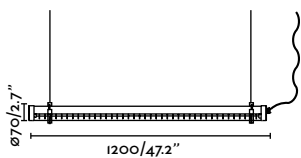
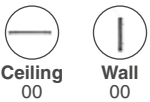





Antiglare louvre to optimize visual confort.





## Scuba 600

IP66 IK10 incl.

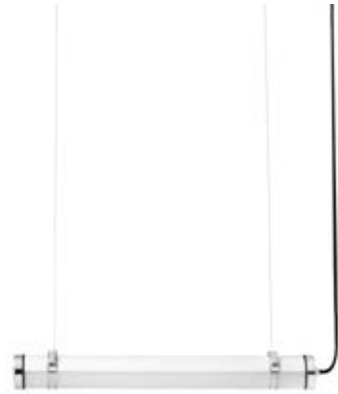

75753  Chrome

<b>Material</b>	<b>Body</b> Stainless steel 316L
	<b>Diff</b> Opal PC
<b>Power</b>	20W
<b>Lumen Output</b>	3200lm
<b>Light Source</b>	SMD LED 3000K
<b>Class</b>	I
<b>CRI</b>	>80
<b>Voltage (V/Hz)</b>	100V-240V/50-60Hz
<b>Beam angle</b>	120°
<b>Cable</b>	3 MT

### Canopy accessory

75755  Matt Black

**Material** **Body** Aluminium



Wall  
840

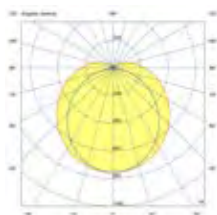
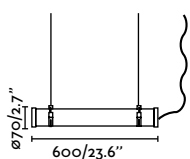

## Scuba 1200

IP66 IK10 incl.



75754  Chrome

<b>Material</b>	<b>Body</b> Stainless steel 316L
	<b>Diff</b> Opal PC
<b>Power</b>	36W
<b>Lumen Output</b>	5760lm
<b>Light Source</b>	SMD LED 3000K
<b>Class</b>	I
<b>CRI</b>	>80
<b>Voltage (V/Hz)</b>	100V-240V/50-60Hz
<b>Beam angle</b>	120°
<b>Cable</b>	3 MT

### Canopy accessory

75755  Matt Black

**Material** **Body** Aluminium

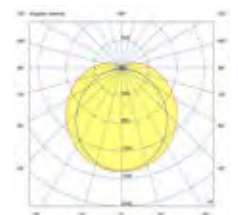
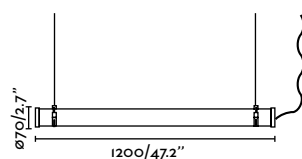

outdoor

Suspended



# Blubs Mistu Moon & Muffin

A timeless proposal  
capable of fitting into  
various outdoor  
atmospheres.

Moon  
74427C-01

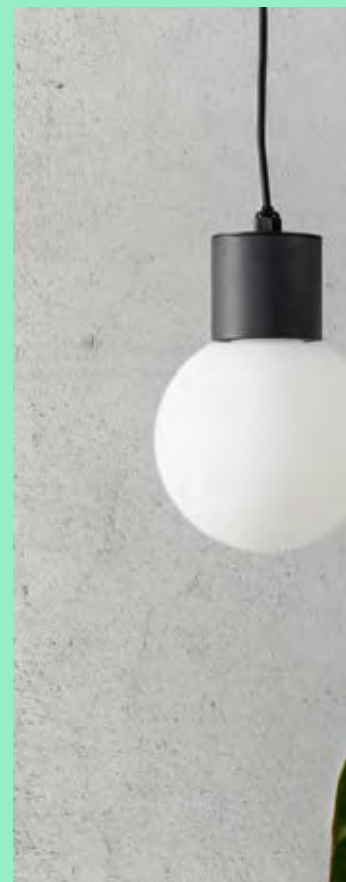

Mistu  
74427C-02

outdoor

Suspended



Muffin 74427C-04

Blubs  
74427C-03





**Blubs**  
Estudi Ribaudí

IP44



74427C-03 ●● Dark Grey + Opal

<b>Material</b>	<b>Body</b> Aluminium
	<b>Diff</b> Opal PMMA
<b>Light Source</b>	1 E27 max. 15W
<b>Bulb incl.</b>	No
<b>Class</b>	I

**Muffin**  
Àlex & Manel Llusà

IP44



74427C-04 ●● Dark Grey + Opal

<b>Material</b>	<b>Body</b> Aluminium
	<b>Diff</b> Opal PMMA
<b>Light Source</b>	1 E27 max. 15W
<b>Bulb incl.</b>	No
<b>Class</b>	I

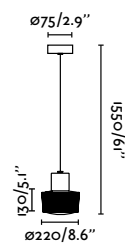
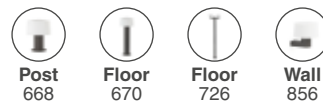
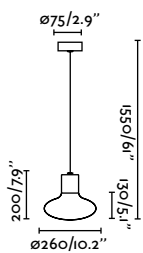
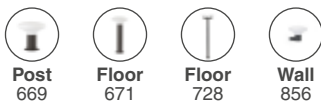

**Mistu**  
Faro Lab

IP44



74427C-02 ●● Dark Grey + Opal

<b>Material</b>	<b>Body</b> Aluminium
	<b>Diff</b> Opal PMMA
<b>Light Source</b>	1 E27 max. 15W
<b>Bulb incl.</b>	No
<b>Class</b>	I

**Moon**  
Faro Lab

IP44



74427C-01 ●● Dark Grey + Opal

<b>Material</b>	<b>Body</b> Aluminium
	<b>Diff</b> Opal PMMA
<b>Light Source</b>	1 E27 max. 15W
<b>Bulb incl.</b>	No
<b>Class</b>	I

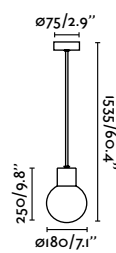
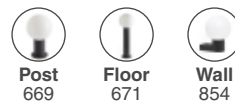
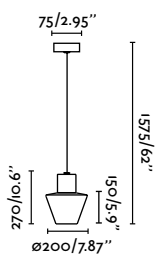
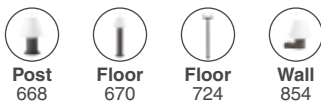

## Nautica 260

IP33



- 71106   Matt White + Matt Copper  
 71138  Rust Brown

<b>Material</b>	<b>Body Steel</b>
	<b>Diff Transparent Glass</b>
<b>Light Source</b>	1 E27 max. 15W
<b>Bulb incl.</b>	No
<b>Class</b>	I
<b>Cable</b>	1 MT

## Nautica 340

IP33



- 71139  Rust Brown

<b>Material</b>	<b>Body Steel</b>
	<b>Diff Transparent Glass</b>
<b>Light Source</b>	1 E27 max. 15W
<b>Bulb incl.</b>	No
<b>Class</b>	I
<b>Cable</b>	1 MT



Wall  
862



Floor  
730

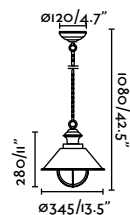
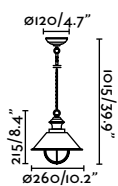

outdoor

Suspended



Nautica 260 71138



Nautica 340 71139





# CEILING

## Tami

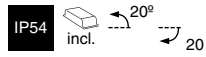

70799

● Dark Grey

<b>Material</b>	<b>Body Aluminium</b>
	<b>Diff Transparent Glass</b>
<b>Power</b>	9W
<b>Lumen Output</b>	600lm
<b>Light Source</b>	COB LED 3000K
<b>Class</b>	I
<b>CRI</b>	>80
<b>Voltage (V/Hz)</b>	100V-240V/50-60Hz
<b>Beam angle</b>	40°

## Goz



70575

● Dark Grey

<b>Material</b>	<b>Body Aluminium</b>
	<b>Diff Transparent Glass</b>
<b>Power</b>	9W
<b>Lumen Output</b>	646lm
<b>Light Source</b>	COB LED 3000K
<b>Class</b>	I
<b>CRI</b>	>80
<b>Voltage (V/Hz)</b>	100V-240V/50-60Hz
<b>Beam angle</b>	18°

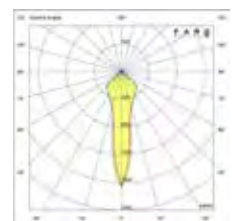
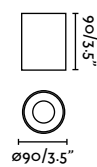
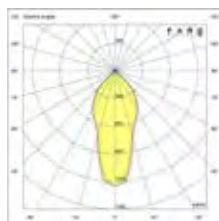
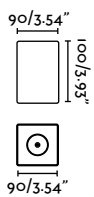

outdoor

Ceiling

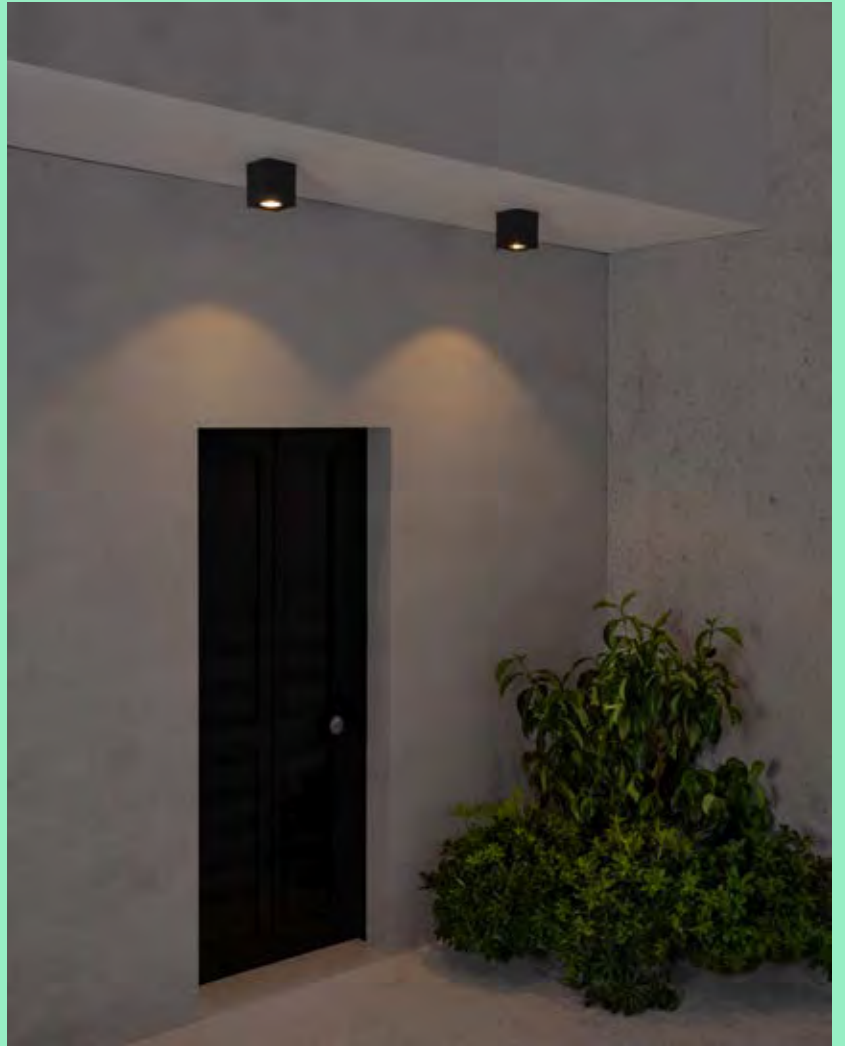

Tami 70799



Goz 70575



## Olot

IP44



- 71372 ● Matt White
- 71374 ● Dark Grey

<b>Material</b>	<b>Body</b> Aluminium
	<b>Diff</b> Transparent Glass
<b>Light Source</b>	1 GU10 max. 8W
<b>Bulb incl.</b>	No
<b>Class</b>	I

## Tasa

IP44 IK06



- 70806 ● Dark Grey
- 70821 ● Matt White

<b>Material</b>	<b>Body</b> Aluminium
	<b>Diff</b> Transparent Glass
<b>Light Source</b>	1 E27 max. 15W
<b>Bulb incl.</b>	No
<b>Class</b>	I

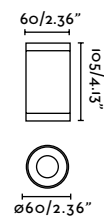
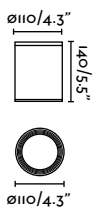



Tasa 70821



Olot 71372

# Kila 200

IP65



- 71740 ●● Dark Grey + Transparent
- 71741 ●● Dark Grey + Smoked
- 71742 ●● Dark Grey + Amber

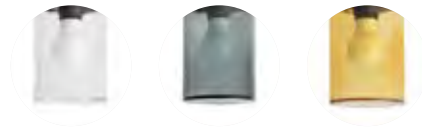

<b>Material</b>	<b>Body</b> Aluminium
	<b>Diff</b> Transparent Glass
<b>Light Source</b>	1 E27 max. 15W
<b>Bulb incl.</b>	No
<b>Class</b>	I



Floor  
654



Wall  
850

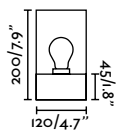

Kila

outdoor

Ceiling



Kila 200 71740

825



## Scuba louver 1200

IP65 IK10 incl.

NEW



75758-110 ● Black

<b>Material</b>	<b>Body</b> Aluminium
	<b>Diff</b> Transparent PC
<b>Power</b>	36W
<b>Lumen Output</b>	2888lm
<b>Light Source</b>	SMD LED 2700K
<b>Class</b>	I
<b>CRI</b>	>90
<b>Voltage (V/Hz)</b>	100V-240V/50-60Hz
<b>Beam angle</b>	80x130°
<b>Cable</b>	3 MT



section\_  
pagina



Wall  
841

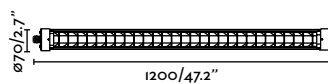

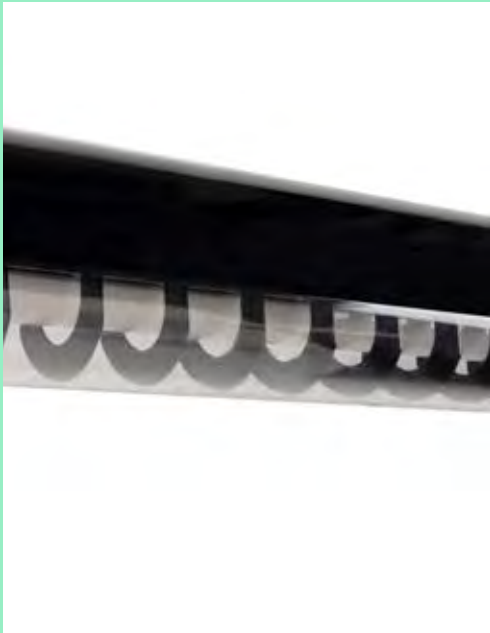

Antiglare louver to optimize visual confort.



## Dakron

IP65 IK10 SEA SIDE SUITABLE



70722

● Matt White

<b>Material</b>	<b>Body</b> ABS
	<b>Diff</b> Opal PC
<b>Light Source</b>	1 E27 max. 15W
<b>Bulb incl.</b>	No
<b>Class</b>	II

## Yen

IP54 IK10



70690

● Grey

<b>Material</b>	<b>Body</b> Aluminium
	<b>Diff</b> Opal PC
<b>Light Source</b>	1 E27 max. 15W
<b>Bulb incl.</b>	No
<b>Class</b>	I

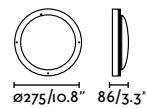
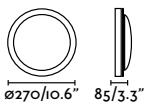



Dakron 70722

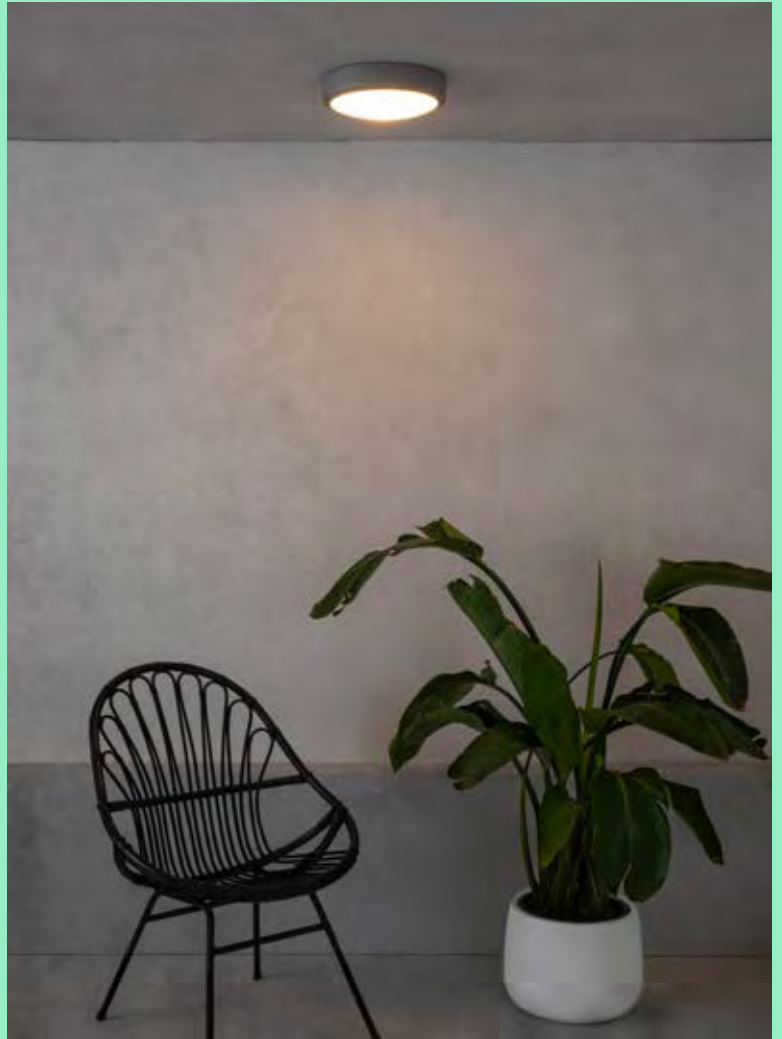

Yen 70690





**OUTDOOR**

**LIGHTING**

# **SURFACE**

**Balic**  
Yembarastudio

IP65 IK06 incl. DIM



70294-110 ● Black

<b>Material</b>	<b>Body</b> Aluminium <b>Diff</b> Prism Glass
<b>Power</b>	8W
<b>Lumen Output</b>	813/870/896lm
<b>Light Source</b>	SMD LED
<b>Dimmable K</b>	2700 - 3000 - 4000K
<b>Class</b>	I
<b>CRI</b>	>=80
<b>Voltage (V/Hz)</b>	110V/50-60Hz

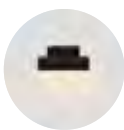

2700K



3000K



4000K

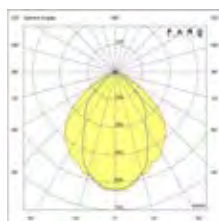
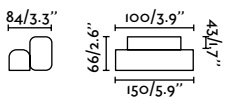



# Balic

Design Yembarastudio

outdoor

Surface





**Pals**  
Faro Lab

IP65 IK06



- 70290  Matt White
- 70291  Dark Grey

<b>Material</b>	<b>Body</b> Aluminium
	<b>Diff</b> Opal Glass
<b>Light Source</b>	1 E27 max. 15W
<b>Bulb incl.</b>	No
<b>Class</b>	I

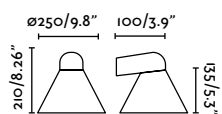

# Pals

Design Faro Lab



Pals 70291



Pals 70290

**Bronx**  
Àlex & Manel Llusçà

IP44



- 71194  Brown
- 71195  White
- 71196  Dark Grey

<b>Material</b>	<b>Body</b> Aluminium <b>Diff</b> Transparent Glass
<b>Light Source</b>	1 GU10 max. 8W
<b>Bulb incl.</b>	No
<b>Class</b>	I

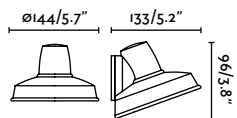

outdoor

Surface





Scuba **NEW**

Antriglare louver  
to optimize visual  
confort



Scuba 1200 75751



Scuba louver 600 75756

Scuba 600  
75750



## Scuba 600

IP66 IK10 incl.



75750  Chrome

<b>Material</b>	<b>Body</b> Stainless steel 316L
	<b>Diff</b> Opal PC
<b>Power</b>	20W
<b>Lumen Output</b>	3200lm
<b>Light Source</b>	SMD LED 3000K
<b>Class</b>	I
<b>CRI</b>	>80
<b>Voltage (V/Hz)</b>	100V-240V/50-60Hz
<b>Beam angle</b>	120°
<b>Cable</b>	3 MT

## Scuba 1200

IP66 IK10 incl.



75751  Chrome

<b>Material</b>	<b>Body</b> Stainless steel 316L
	<b>Diff</b> Opal PC
<b>Power</b>	36W
<b>Lumen Output</b>	5760lm
<b>Light Source</b>	SMD LED 3000K
<b>Class</b>	I
<b>CRI</b>	>80
<b>Voltage (V/Hz)</b>	100V-240V/50-60Hz
<b>Beam angle</b>	120°
<b>Cable</b>	3 MT

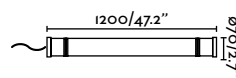
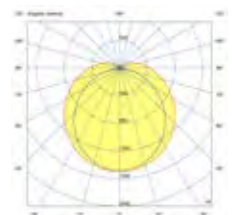
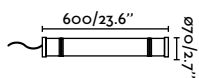
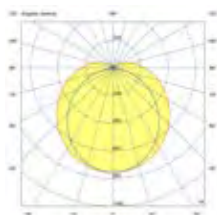

## Scuba louver 600

IP65 IK10 incl.

NEW



75756-110 ● Black

<b>Material</b>	<b>Body</b> Aluminium
	<b>Diff</b> Transparent PC
<b>Power</b>	20W
<b>Lumen Output</b>	1280lm
<b>Light Source</b>	SMD LED 2700K
<b>Class</b>	I
<b>CRI</b>	>90
<b>Voltage (V/Hz)</b>	100V-240V/50-60Hz
<b>Beam angle</b>	60°
<b>Cable</b>	1.5 MT

## Scuba louver 1200

IP65 IK10 incl.

NEW



75757-110 ● Black

<b>Material</b>	<b>Body</b> Aluminium
	<b>Diff</b> Transparent PC
<b>Power</b>	36W
<b>Lumen Output</b>	1510lm
<b>Light Source</b>	SMD LED 2700K
<b>Class</b>	I
<b>CRI</b>	>90
<b>Voltage (V/Hz)</b>	100V-240V/50-60Hz
<b>Beam angle</b>	60°
<b>Cable</b>	1.5 MT

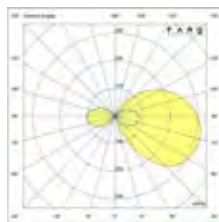
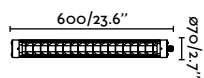



**Tram**  
Estudi Ribaudí

IP44



75533 ● Matt White

<b>Material</b>	<b>Body</b> Aluminium
	<b>Diff</b> Opal PMMA
<b>Light Source</b>	1 E27 max. 15W
<b>Bulb incl.</b>	No
<b>Class</b>	I

**Datna**  
Àlex & Manel Llusçà

IP44

IK05

SEA SIDE  
SUITABLE



74440 ● Dark Grey

<b>Material</b>	<b>Body</b> Aluminium
	<b>Diff</b> Opal PC
<b>Light Source</b>	1 E27 max. 15W
<b>Bulb incl.</b>	No
<b>Class</b>	I

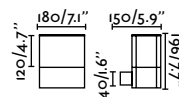
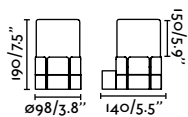



Datna 74440



Tram 75533

**Block 135**  
Àlex & Manel Llusçà

IP65 IK06 SEA SIDE SUITABLE



74139 ● Grey Cement

<b>Material</b>	<b>Body</b> Concrete
	<b>Diff</b> Opal Glass
<b>Light Source</b>	1 E27 max. 15W
<b>Bulb incl.</b>	No
<b>Class</b>	I



Floor  
644



outdoor

Surface

# Block

Design Àlex & Manel Llusçà





**Mask**  
Lucid Product Design

IP65 IK06 incl. SEA SIDE SUITABLE



71279 ● Dark Grey

<b>Material</b>	Body Aluminium Diff Opal Glass
<b>Power</b>	15W
<b>Lumen Output</b>	550lm
<b>Light Source</b>	SMD LED 3000K
<b>Class</b>	I
<b>CRI</b>	>80
<b>Voltage (V/Hz)</b>	100V-240V/50-60Hz

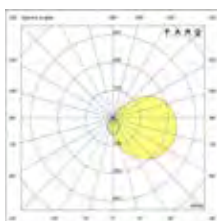
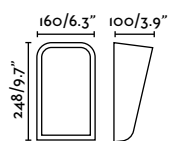

# Mask

**Design** Lucid Product Design



It is made of injected aluminium and has an opal diffuser. IP65.

Robust wall lamp that can be located near the sea as it is highly resistant to corrosion by salinity.

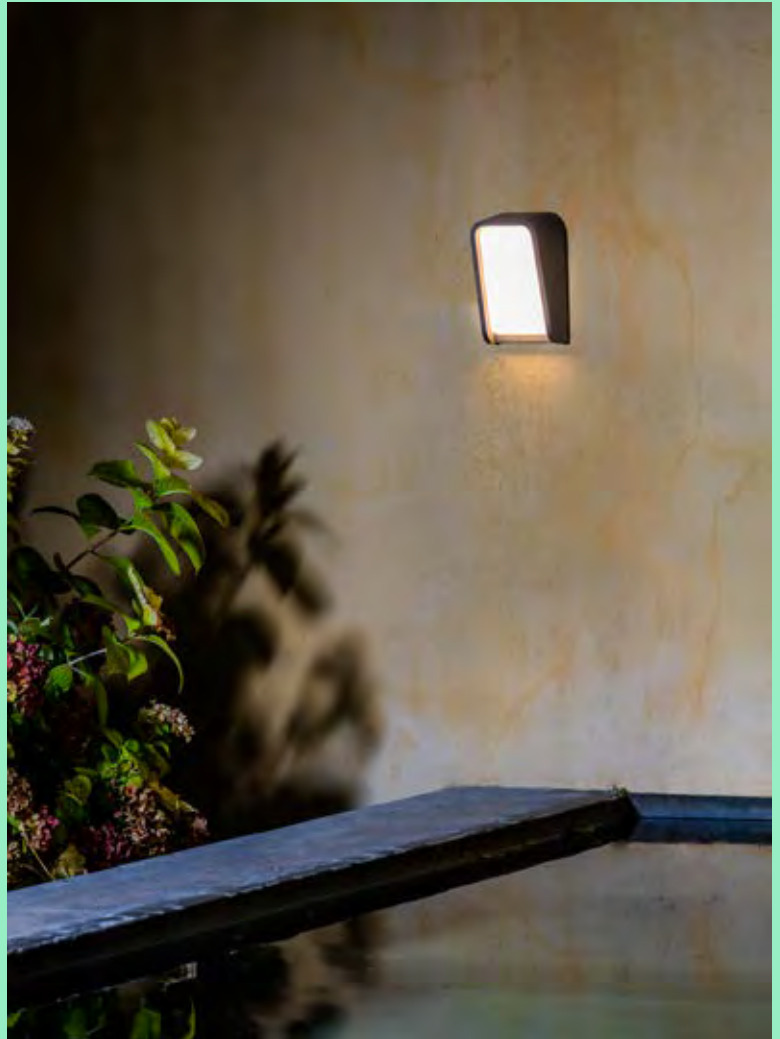

**Twist**  
Estudi Ribaudí

IP65  incl.



71285

● Dark Grey

<b>Material</b>	<b>Body</b> Aluminium
	<b>Diff</b> Opal PC
<b>Power</b>	10W
<b>Lumen Output</b>	500lm
<b>Light Source</b>	SMD LED 3000K
<b>Class</b>	I
<b>CRI</b>	>80
<b>Voltage (V/Hz)</b>	100V-240V/50-60Hz



Floor  
648



Floor  
648

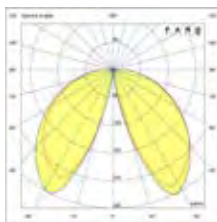
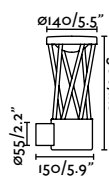

# Twist

**Design** Estudi Ribaudí

Turn outdoor lighting upside down. Twist is your choice. It is original, fresh and fun and creates an effect of lights and shadows on the surfaces where it is located.







# Kila

IP65



- 71743  Dark Grey + Transparent
- 71744  Dark Grey + Smoked
- 71745  Dark Grey + Amber

<b>Material</b>	<b>Body</b> Aluminium
	<b>Diff</b> Transparent Glass
<b>Light Source</b>	1 E27 max. 15W
<b>Bulb incl.</b>	No
<b>Class</b>	I



**Floor**  
654



**Ceiling**  
824

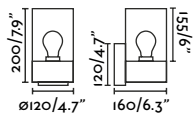

outdoor

Surface



Kila 71745

851

## Wilma 280

IP44



74998

● Dark Grey + Opal

<b>Material</b>	<b>Body</b> Aluminium
	<b>Diff</b> Opal PC
<b>Light Source</b>	1 E27 max. 15W
<b>Bulb incl.</b>	No
<b>Class</b>	I

## Wilma 320

IP44



75000

● Dark Grey + Opal

<b>Material</b>	<b>Body</b> Aluminium
	<b>Diff</b> Opal PC
<b>Light Source</b>	1 E27 max. 15W
<b>Bulb incl.</b>	No
<b>Class</b>	I



Post  
660



Floor  
660

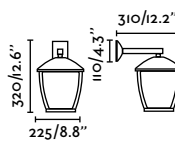
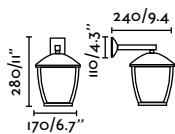

outdoor

Surface



Wilma 280 74998

853



**Mistu**  
Faro Lab

IP44



74432A-02 ●● Dark Grey + Opal

<b>Material</b>	<b>Body</b> Aluminium
	<b>Diff</b> Opal PMMA
<b>Light Source</b>	1 E27 max. 15W
<b>Bulb incl.</b>	No
<b>Class</b>	I

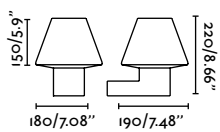
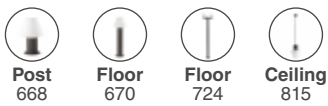

**Moon**  
Faro Lab

IP44



74432A-01 ●● Dark Grey + Opal

<b>Material</b>	<b>Body</b> Aluminium
	<b>Diff</b> Opal PMMA
<b>Light Source</b>	1 E27 max. 15W
<b>Bulb incl.</b>	No
<b>Class</b>	I

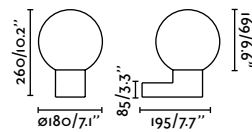
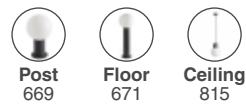

outdoor

Surface



Moon 74432A-01

855

**Muffin**  
Àlex & Manel Llusçà

IP44



74432A-04 ●● Dark Grey + Opal

<b>Material</b>	<b>Body</b> Aluminium
	<b>Diff</b> Opal PMMA
<b>Light Source</b>	1 E27 max. 15W
<b>Bulb incl.</b>	No
<b>Class</b>	I



**Post**  
668



**Floor**  
670



**Floor**  
726



**Ceiling**  
814

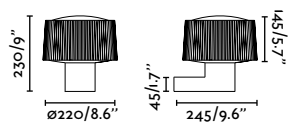





**Blubs**  
Estudi Ribaudí

IP44



74432A-03 ● Dark Grey + Opal

<b>Material</b>	<b>Body</b> Aluminium
	<b>Diff</b> Opal PMMA
<b>Light Source</b>	1 E27 max. 15W
<b>Bulb incl.</b>	No
<b>Class</b>	I



**Post**  
669



**Floor**  
671



**Floor**  
728



**Ceiling**  
814

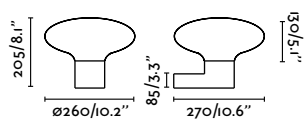



outdoor

Surface





## Argot

IP44



71424

● Rust Brown

<b>Material</b>	<b>Body Steel</b>
	<b>Diff Transparent Glass</b>
<b>Light Source</b>	1 E27 max. 15W
<b>Bulb incl.</b>	No
<b>Class</b>	I

## Dado

IP23



71606

● Rust Brown

<b>Material</b>	<b>Body Steel</b>
	<b>Diff Transparent Glass</b>
<b>Light Source</b>	1 E27 max. 15W
<b>Bulb incl.</b>	No
<b>Class</b>	I

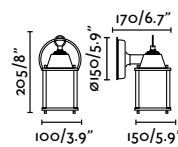
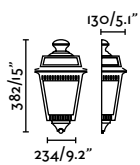

outdoor

Surface



Dado 71606



Argot 71424



## Nautica 310

IP33



71110

● Rust Brown

## Nautica 280

IP33



71128

● Rust Brown

## Nautica 350

IP33



71129

● Rust Brown

<b>Material</b>	<b>Body Steel</b>
	<b>Diff Transparent Glass</b>
<b>Light Source</b>	1 E27 max. 15W
<b>Bulb incl.</b>	No
<b>Class</b>	I

<b>Material</b>	<b>Body Steel</b>
	<b>Diff Transparent Glass</b>
<b>Light Source</b>	1 E27 max. 15W
<b>Bulb incl.</b>	No
<b>Class</b>	I

<b>Material</b>	<b>Body Steel</b>
	<b>Diff Transparent Glass</b>
<b>Light Source</b>	1 E27 max. 15W
<b>Bulb incl.</b>	No
<b>Class</b>	I



Floor  
730



Ceiling  
816

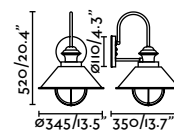
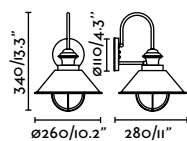
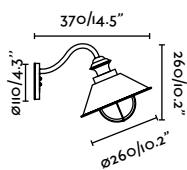



Nautica 280 71128

## Estoril

IP33 IK06



71140

● Rust Brown

<b>Material</b>	<b>Body Steel</b>
	<b>Diff Transparent Glass</b>
<b>Light Source</b>	1 E27 max. 15W
<b>Bulb incl.</b>	No
<b>Class</b>	I

## Wally

IP44



74261

● Rust Brown

<b>Material</b>	<b>Body Steel</b>
	<b>Diff Transparent Glass</b>
<b>Light Source</b>	1 E27 max. 15W
<b>Bulb incl.</b>	No
<b>Class</b>	I

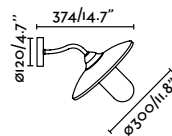
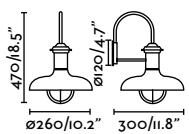

outdoor

Surface



Estoril 71140



Wally 74261



## Timon

IP44



70996

Brass

<b>Material</b>	<b>Body Brass</b>
	<b>Diff Transparent Glass</b>
<b>Light Source</b>	1 E27 max. 15W
<b>Bulb incl.</b>	No
<b>Class</b>	I

## Noray

IP44 IK03



70999

Brass

<b>Material</b>	<b>Body Brass</b>
	<b>Diff Transparent Glass</b>
<b>Light Source</b>	1 E27 max. 15W
<b>Bulb incl.</b>	No
<b>Class</b>	I

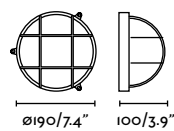
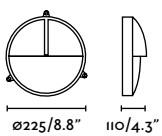

outdoor

Surface



Cabo

IP44 IK05



70998

Brass

<b>Material</b>	<b>Body Brass</b>
	<b>Diff Transparent Glass</b>
<b>Light Source</b>	1 E27 max. 15W
<b>Bulb incl.</b>	No
<b>Class</b>	I

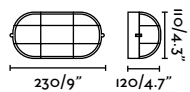

Borda

IP44



70997

Brass

<b>Material</b>	<b>Body Brass</b>
	<b>Diff Transparent Glass</b>
<b>Light Source</b>	1 E27 max. 15W
<b>Bulb incl.</b>	No
<b>Class</b>	I

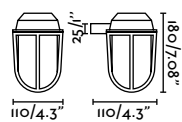

Nahir

IP44



70992

Brass

<b>Material</b>	<b>Body Brass</b>
	<b>Diff Transparent Glass</b>
<b>Light Source</b>	1 E27 max. 15W
<b>Bulb incl.</b>	No
<b>Class</b>	I

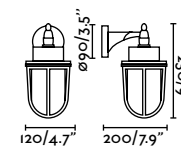



outdoor

Surface



Borda 70997

869



## Nala

IP54



70773

● Dark Grey

<b>Material</b>	<b>Body Aluminium</b>
	<b>Diff Transparent Glass</b>
<b>Light Source</b>	1 E27 max. 15W
<b>Bulb incl.</b>	No
<b>Class</b>	I

## Tamashi

IP65



71303

● Dark Grey

<b>Material</b>	<b>Body Aluminium</b>
	<b>Diff Transparent Glass</b>
<b>Light Source</b>	1 E27 max. 15W
<b>Bulb incl.</b>	No
<b>Class</b>	I

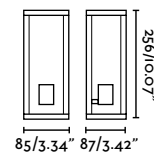
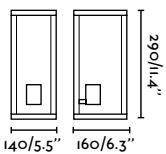



Nala 70773



Tamashi 71303

## Pomo

IP65 IK06



71306

● Dark Grey

<b>Material</b>	<b>Body</b> Aluminium
	<b>Diff</b> Transparent Glass
<b>Light Source</b>	2 E27 max. 15W
<b>Bulb incl.</b>	No
<b>Class</b>	I

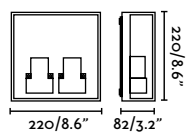

## Pivot

IP65 IK06 incl.



71304

● Matt White

71305

● Dark Grey

<b>Material</b>	<b>Body</b> Aluminium
	<b>Diff</b> Opal Glass
<b>Power</b>	10W
<b>Lumen Output</b>	500lm
<b>Light Source</b>	SMD LED 3000K
<b>Class</b>	I
<b>CRI</b>	>80
<b>Voltage (V/Hz)</b>	100V-240V/50-60Hz

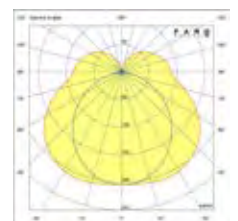
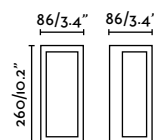

outdoor

Surface



Pomo 71306

873



## Sun

IP54  incl.



70823 ● Dark Grey

<b>Material</b>	<b>Body</b> Aluminium
	<b>Diff</b> Opal PC
<b>Power</b>	4,4W
<b>Lumen Output</b>	275lm
<b>Light Source</b>	SMD LED 3000K
<b>Class</b>	I
<b>CRI</b>	>80
<b>Voltage (V/Hz)</b>	100V-240V/50-60Hz

## Tom 190

IP65 IK10  incl. **SEA SIDE SUITABLE**



70665-110 ● Matt White

70666-110 ● Dark Grey

<b>Material</b>	<b>Body</b> ABS
	<b>Diff</b> Opal PC
<b>Power</b>	7W
<b>Lumen Output</b>	400lm
<b>Light Source</b>	SMD LED 3000K
<b>Class</b>	II
<b>CRI</b>	>80
<b>Voltage (V/Hz)</b>	110V/50-60Hz

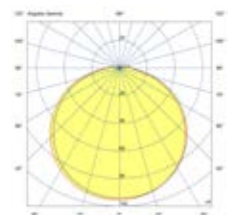
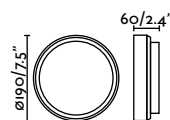
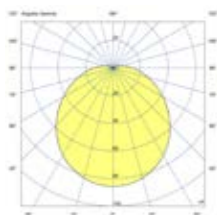
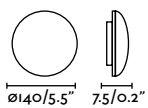

outdoor

Surface



Sun 70823

875

## Kubick

IP44 IK06



70689 ● Dark Grey  
70715 ● Grey

<b>Material</b>	<b>Body</b> Aluminium <b>Diff</b> Opal PC
<b>Light Source</b>	1 E27 max. 15W
<b>Bulb incl.</b>	No
<b>Class</b>	I

## Hikari

IP65 IK10 incl.



71274 ● Dark Grey

<b>Material</b>	<b>Body</b> Aluminium <b>Diff</b> Opal PC
<b>Power</b>	10W
<b>Lumen Output</b>	400lm
<b>Light Source</b>	SMD LED 3000K
<b>Class</b>	I
<b>CRI</b>	>80
<b>Voltage (V/Hz)</b>	100V-240V/50-60Hz

## Lur

IP54 IK06 incl.



70827 ● Dark Grey

<b>Material</b>	<b>Body</b> Aluminium <b>Diff</b> Opal PMMA
<b>Power</b>	12W
<b>Lumen Output</b>	950lm
<b>Light Source</b>	SMD LED 3000K
<b>Class</b>	I
<b>CRI</b>	>80
<b>Voltage (V/Hz)</b>	100V-240V/50-60Hz

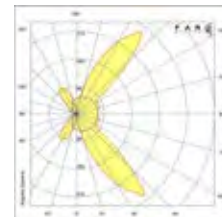
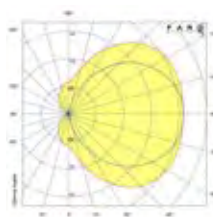
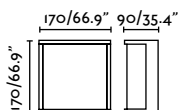
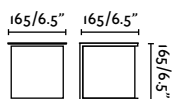

outdoor

Surface



Kubick 70715

877



## Negus

IP54 IK10



70696

● Grey

<b>Material</b>	<b>Body Aluminium</b>
	<b>Diff Opal PC</b>
<b>Light Source</b>	1 E27 max. 15W
<b>Bulb incl.</b>	No
<b>Class</b>	I

## Bonn

IP44 IK06



70697

● Dark Grey

<b>Material</b>	<b>Body Aluminium</b>
	<b>Diff Opal PC</b>
<b>Light Source</b>	1 E27 max. 15W
<b>Bulb incl.</b>	No
<b>Class</b>	I

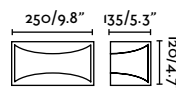
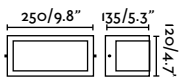

outdoor

Surface



## Natron

IP54 IK06



70887

● Dark Grey

<b>Material</b>	<b>Body</b> Aluminium
	<b>Diff</b> Opal Glass
<b>Light Source</b>	1 E27 max. 15W
<b>Bulb incl.</b>	No
<b>Class</b>	I

## Tejo

IP54 IK06



70573

● Dark Grey

70573B

● Matt White

<b>Material</b>	<b>Body</b> Aluminium
	<b>Diff</b> Opal PC
<b>Light Source</b>	1 E27 max. 15W
<b>Bulb incl.</b>	No
<b>Class</b>	I

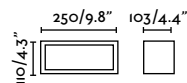
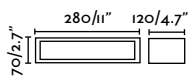

outdoor

Surface



Tejo 70573B

881



Mol

IP44

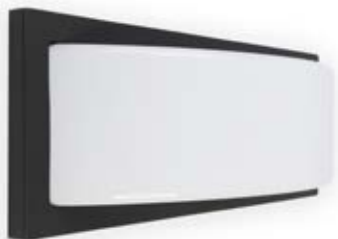

70720

● Dark Grey

<b>Material</b>	<b>Body</b> Aluminium
	<b>Diff</b> Opal PC
<b>Light Source</b>	1 E27 max. 15W
<b>Bulb incl.</b>	No
<b>Class</b>	I

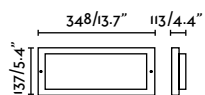

882



Pol

IP54  incl.



70829

● Dark Grey

<b>Material</b>	<b>Body</b> Aluminium
	<b>Diff</b> Opal PMMA
<b>Power</b>	8W
<b>Lumen Output</b>	550lm
<b>Light Source</b>	SMD LED 3000K
<b>Class</b>	I
<b>CRI</b>	>80
<b>Voltage (V/Hz)</b>	100V-240V/50-60Hz

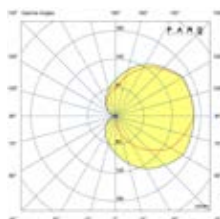
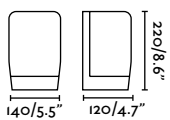

outdoor

Surface



Pol 70829

885



Cela

IP54



72280

● Satin Stainless

Cela stripped

IP54



72281

● Satin Stainless

Fedon

IP54



70714

● Satin Stainless

<b>Material</b>	<b>Body</b> Stainless steel 304
	<b>Diff</b> Opal PC
<b>Light Source</b>	1 E27 max. 15W
<b>Bulb incl.</b>	No
<b>Class</b>	II

<b>Material</b>	<b>Body</b> Stainless steel 304
	<b>Diff</b> Opal PC
<b>Light Source</b>	1 E27 max. 15W
<b>Bulb incl.</b>	No
<b>Class</b>	II

<b>Material</b>	<b>Body</b> Stainless steel 304
	<b>Diff</b> Opal PC
<b>Light Source</b>	1 E27 max. 15W
<b>Bulb incl.</b>	No
<b>Class</b>	I

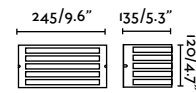
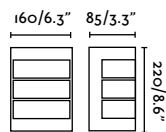
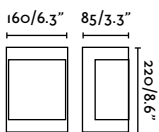

outdoor

Surface



Cela 72280

887

## Estay

IP44



- 72010  Matt White
- 72011  Matt Black

<b>Material</b>	<b>Body</b> Aluminium
	<b>Diff</b> Opal Glass
<b>Light Source</b>	1 E27 max. 15W
<b>Bulb incl.</b>	No
<b>Class</b>	I

## Derby 200

IP44



- 72000  Matt White
- 72001  Matt Black

<b>Material</b>	<b>Body</b> Aluminium
	<b>Diff</b> Opal Glass
<b>Light Source</b>	1 E27 max. 15W
<b>Bulb incl.</b>	No
<b>Class</b>	I

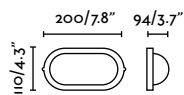

## Derby 283

IP44



- 72002  Matt White

<b>Material</b>	<b>Body</b> Aluminium
	<b>Diff</b> Opal Glass
<b>Light Source</b>	1 E27 max. 15W
<b>Bulb incl.</b>	No
<b>Class</b>	I

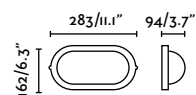



outdoor

Surface

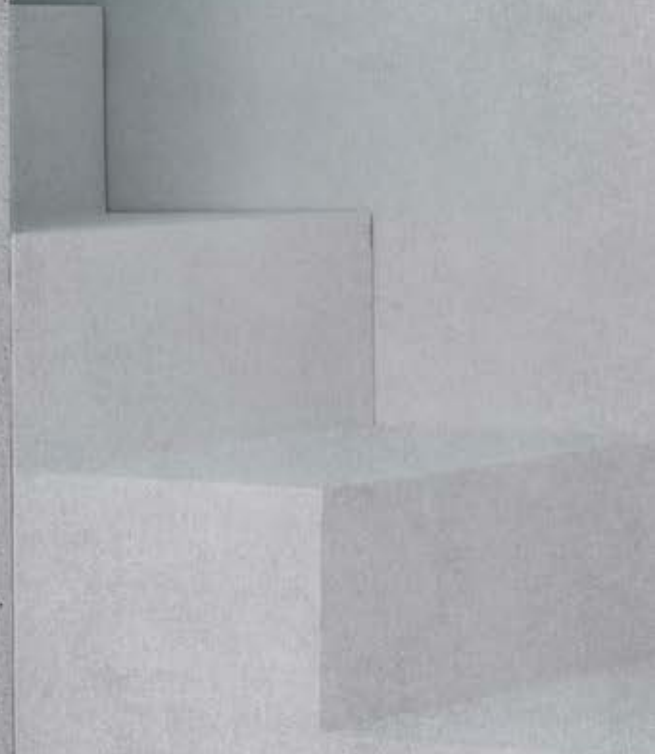

Estay 72011

889



**Bu-Oh**  
Estudi Ribaudí

IP65  incl.



- 71212  Dark Grey
- 71215  Matt White

<b>Material</b>	<b>Body</b> Aluminium
	<b>Diff</b> Opal PC
<b>Power</b>	12W
<b>Lumen Output</b>	310lm
<b>Light Source</b>	SMD LED 3000K
<b>Class</b>	I
<b>CRI</b>	>80
<b>Voltage (V/Hz)</b>	100V-240V/50-60Hz

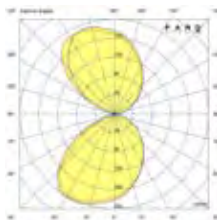
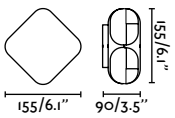

# Bu-Oh

Design Estudi Ribaudí

Bu-oh! is a collection of intimidating-looking outdoor luminaires with unparalleled elegance and beauty. Ideal for signalling outdoor environments in an original and ingenious way.



Bu-Oh 71212

**Lotus**  
Estudi Ribaudí

IP65 IK08 incl.



- 71222 ● Matt White
- 71223 ● Dark Grey

<b>Material</b>	<b>Body</b> Aluminium
	<b>Diff</b> Opal PC
<b>Power</b>	18W
<b>Lumen Output</b>	1700lm
<b>Light Source</b>	SMD LED 3000K
<b>Class</b>	I
<b>CRI</b>	>80
<b>Voltage (V/Hz)</b>	100V-240V/50-60Hz

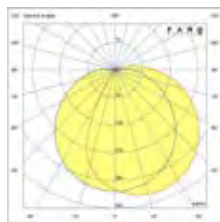
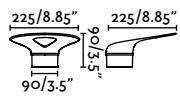

# Lotus

**Design** Estudi Ribaudí

Inspired by the lotus flower, this outdoor collection is made of aluminum which gives it greater robustness and durability.

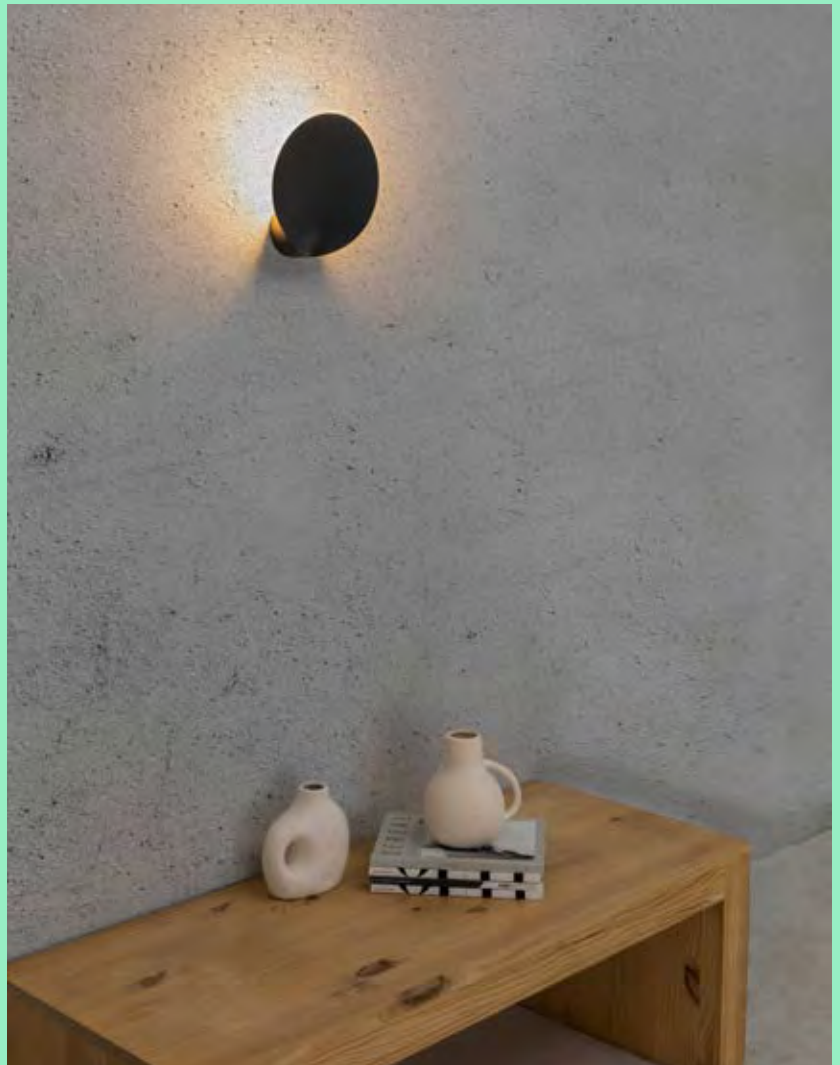

Lotus 71223

The wall lamp offers indirect lighting and the beacons are ideal for illuminating passageways.



**Future**  
Estudi Ribaudí

IP44 IK08 SEA SIDE SUITABLE



- 71516 ● Matt White
- 71517 ● Dark Grey

<b>Material</b>	<b>Body</b> PC
	<b>Diff</b> Opal PC
<b>Light Source</b>	1 E27 max. 15W
<b>Bulb incl.</b>	No
<b>Class</b>	II

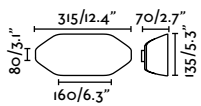

**View**  
Estudi Ribaudí

IP54 SEA SIDE SUITABLE



- 71519 ● Dark Grey

<b>Material</b>	<b>Body</b> ABS+PC
	<b>Diff</b> Opal PP
<b>Light Source</b>	1 E27 max. 15W
<b>Bulb incl.</b>	No
<b>Class</b>	II

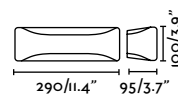

# View

Design Estudi Ribaudí

A futuristic luminaire that represents a parenthesis of light that contributes to the creation of calm and relaxed atmospheres in which to enjoy nights and sunsets.

**Dragma**  
Àlex & Manel Llusçà

IP65  incl.



71362L ● Dark Grey

<b>Material</b>	<b>Body</b> Aluminium
	<b>Diff</b> Opal Glass
<b>Power</b>	15W
<b>Lumen Output</b>	500lm
<b>Light Source</b>	SMD LED 3000K
<b>Class</b>	I
<b>CRI</b>	>80
<b>Voltage (V/Hz)</b>	100V-240V/50-60Hz

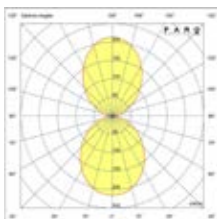
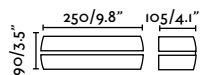



outdoor

Surface



Dragma 71362L



**Ancora**  
Àlex & Manel Llusçà

IP44



74401

● Dark Grey

<b>Material</b>	<b>Body</b> Aluminium
	<b>Diff</b> Opal PC
<b>Light Source</b>	1 E27 max. 15W
<b>Bulb incl.</b>	No
<b>Class</b>	I

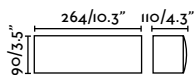

outdoor

Surface



# Takua

IP65 IK06 incl.



- 71277 ● Dark Grey
- 71308 ● Matt White
- 71309 ● Rust Brown

<b>Material</b>	<b>Body</b> Aluminium
	<b>Diff</b> Opal Glass
<b>Power</b>	10W
<b>Lumen Output</b>	450lm
<b>Light Source</b>	SMD LED 3000K
<b>Class</b>	I
<b>CRI</b>	>80
<b>Voltage (V/Hz)</b>	100V-240V/50-60Hz

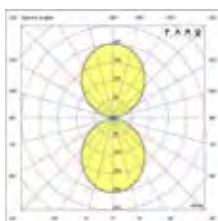
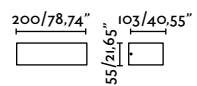



outdoor

Surface





# Oval

IP65 IK06 incl.



71276

● Dark Grey

<b>Material</b>	<b>Body</b> Aluminium
	<b>Diff</b> Opal Glass
<b>Power</b>	10W
<b>Lumen Output</b>	450lm
<b>Light Source</b>	SMD LED 3000K
<b>Class</b>	I
<b>CRI</b>	>80
<b>Voltage (V/Hz)</b>	100V-240V/50-60Hz

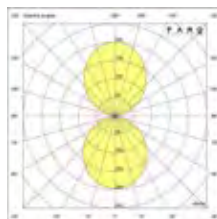
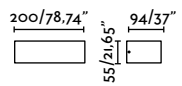



## Doro 220

IP65 IK07 incl.



- 71899-110 ● Teak
- 71900-110 ● Matt White
- 71901-110 ● Dark Grey
- 71902-110 ● Rust Brown

<b>Material</b>	<b>Body</b> Wood+Aluminium
	<b>Diff</b> Prism Glass
<b>Power</b>	2x6,5W
<b>Lumen Output</b>	2x500lm
<b>Light Source</b>	SMD LED 3000K
<b>Class</b>	I
<b>CRI</b>	>=80
<b>Voltage (V/Hz)</b>	110V/50-60Hz
<b>Beam angle</b>	95°

## Doro 380

IP65 IK07 incl.



- 71903 ● Matt White
- 71904 ● Dark Grey
- 71905 ● Rust Brown

<b>Material</b>	<b>Body</b> Aluminium
	<b>Diff</b> Prism Glass
<b>Power</b>	2x10W
<b>Lumen Output</b>	2x900lm
<b>Light Source</b>	SMD LED 3000K
<b>Class</b>	I
<b>CRI</b>	>80
<b>Voltage (V/Hz)</b>	100V-240V/50-60Hz

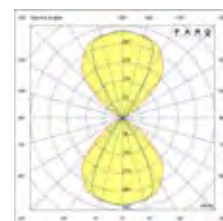
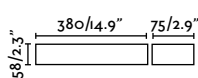
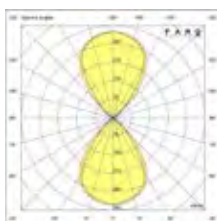
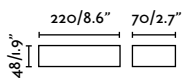

outdoor

Surface



Doro 380 71905

905



# Lako

IP65 IK07 incl.



- 71898-110 ● Teak
- 71909-110 ● Matt White
- 71910-110 ● Dark Grey
- 71911-110 ● Rust Brown

<b>Material</b>	<b>Body</b> Wood+Aluminium
	<b>Diff</b> Prism Glass
<b>Power</b>	8W
<b>Lumen Output</b>	600lm
<b>Light Source</b>	SMD LED 3000K
<b>Class</b>	I
<b>CRI</b>	>=80
<b>Voltage (V/Hz)</b>	110V/50-60Hz
<b>Beam angle</b>	90°

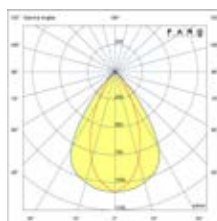
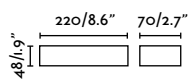

outdoor

Surface



Lako 71898-110

907

## Tond 1L

IP54 IK06 incl.



71915-110  
2700K  
71916-110  
3000K

- Dark Grey
- Dark Grey

<b>Material</b>	Body Aluminium Diff Transparent Glass
<b>Power</b>	6W
<b>Lumen Output</b>	195lm
<b>Light Source</b>	COB LED
<b>Class</b>	I
<b>CRI</b>	>=80
<b>Voltage (V/Hz)</b>	110V/50-60Hz
<b>Beam angle</b>	50°

## Tond 2L

IP54 IK06 incl.



71917-110  
2700K  
71918-110  
3000K

- Dark Grey
- Dark Grey

<b>Material</b>	Body Aluminium Diff Transparent Glass
<b>Power</b>	2x6W
<b>Lumen Output</b>	2x271lm
<b>Light Source</b>	COB LED
<b>Class</b>	I
<b>CRI</b>	>=80
<b>Voltage (V/Hz)</b>	110V/50-60Hz
<b>Beam angle</b>	50°

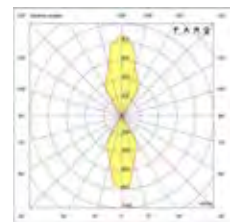
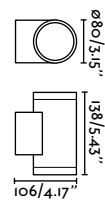
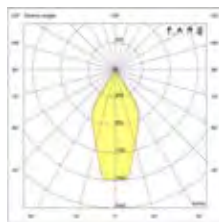
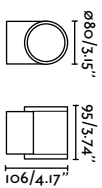

outdoor

Surface





## Aday 113

IP54 IK10 incl.



70644-110 ● Matt White  
70645-110 ● Dark Grey

<b>Material</b>	<b>Body</b> Aluminium <b>Diff</b> Opal Glass
<b>Power</b>	2x3W
<b>Lumen Output</b>	2x225lm
<b>Light Source</b>	SMD LED 3000K
<b>Class</b>	I
<b>CRI</b>	>80
<b>Voltage (V/Hz)</b>	110V/50-60Hz

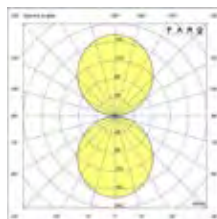
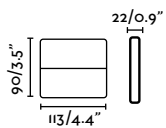

## Aday 175

IP54 IK10 incl.



70646-110 ● Matt White  
70647-110 ● Dark Grey

<b>Material</b>	<b>Body</b> Aluminium <b>Diff</b> Opal Glass
<b>Power</b>	2x6,5W
<b>Lumen Output</b>	2x393lm
<b>Light Source</b>	SMD LED 3000K
<b>Class</b>	I
<b>CRI</b>	>80
<b>Voltage (V/Hz)</b>	110V/50-60Hz

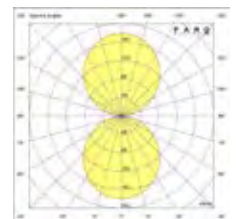
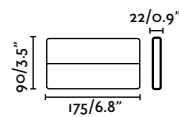

outdoor

Surface



## West 1

IP54 IK06



70888

● Dark Grey

<b>Material</b>	<b>Body Aluminium</b>
	<b>Diff Opal Glass</b>
<b>Light Source</b>	1 E27 max. 15W
<b>Bulb incl.</b>	No
<b>Class</b>	I

## West 2

IP54 IK06



70899

● Dark Grey

<b>Material</b>	<b>Body Aluminium</b>
	<b>Diff Opal Glass</b>
<b>Light Source</b>	1 E27 max. 15W
<b>Bulb incl.</b>	No
<b>Class</b>	I

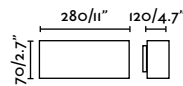
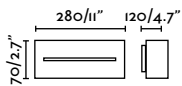



outdoor

Surface



West 1 70888

913



## Lace

IP54 IK06 incl.



70811 ● Dark Grey

<b>Material</b>	<b>Body</b> Aluminium <b>Diff</b> Transparent Glass
<b>Power</b>	2x3W
<b>Lumen Output</b>	2x158lm
<b>Light Source</b>	COB LED 4000K
<b>Class</b>	I
<b>CRI</b>	>80
<b>Voltage (V/Hz)</b>	100V-240V/50-60Hz
<b>Beam angle</b>	110°

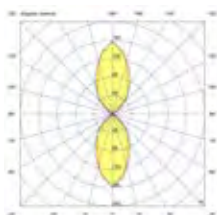
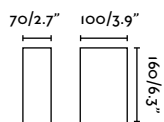

## Bruc

IP54 IK10 incl.



70828 ● Dark Grey

<b>Material</b>	<b>Body</b> Aluminium <b>Diff</b> Opal Glass
<b>Power</b>	13W
<b>Lumen Output</b>	830lm
<b>Light Source</b>	SMD LED 3000K
<b>Class</b>	I
<b>CRI</b>	>80
<b>Voltage (V/Hz)</b>	100V-240V/50-60Hz

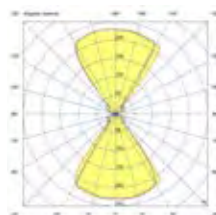
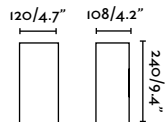

## Ling

IP54 IK06 incl.



70812 ● Dark Grey  
70813 ● Matt White

<b>Material</b>	<b>Body</b> Aluminium <b>Diff</b> Transparent Glass
<b>Power</b>	2x3W
<b>Lumen Output</b>	2x3150lm
<b>Light Source</b>	COB LED 4000K
<b>Class</b>	I
<b>CRI</b>	>80
<b>Voltage (V/Hz)</b>	100V-240V/50-60Hz
<b>Beam angle</b>	110°

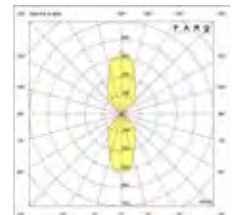
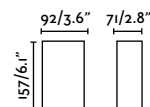

outdoor

Surface



Lace 70811

915

## Lacre

IP54 IK06



70802

● Dark Grey

<b>Material</b>	<b>Body</b> Aluminium <b>Diff</b> Transparent Glass
<b>Light Source</b>	1 E27 max. 15W
<b>Bulb incl.</b>	No
<b>Class</b>	I

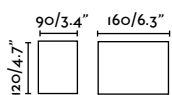

## Canon

IP44 incl.



70566N

● Dark Grey

70567N

● Matt White

<b>Material</b>	<b>Body</b> Aluminium <b>Diff</b> Transparent Glass
<b>Power</b>	4W
<b>Lumen Output</b>	130lm
<b>Light Source</b>	SMD LED 3000K
<b>Class</b>	I
<b>CRI</b>	>80
<b>Voltage (V/Hz)</b>	100V-240V/50-60Hz
<b>Beam angle</b>	120°

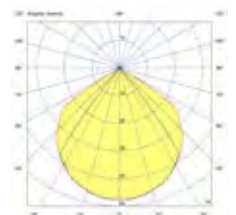
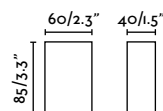

outdoor

Surface



Lacre 70802

917



## Log

IP54 IK06 incl.



70264-110 ● Dark Grey

<b>Material</b>	<b>Body</b> Aluminium <b>Diff</b> Opal PC
<b>Power</b>	9W
<b>Lumen Output</b>	600lm
<b>Light Source</b>	SMD LED 3000K
<b>Class</b>	I
<b>CRI</b>	>80
<b>Voltage (V/Hz)</b>	110V/50-60Hz

## Blind

IP65 IK06 incl.



70267-110 ● Matt White  
70268-110 ● Rust Brown  
70634-110 ● Dark Grey

<b>Material</b>	<b>Body</b> Aluminium <b>Diff</b> Transparent Glass
<b>Power</b>	2x3W
<b>Lumen Output</b>	2x90lm
<b>Light Source</b>	COB LED 3000K
<b>Class</b>	I
<b>CRI</b>	>80
<b>Voltage (V/Hz)</b>	110V/50-60Hz

## Olan

IP65 IK06 incl.



70269-110 ● Matt White  
70270-110 ● Rust Brown  
70637-110 ● Dark Grey

<b>Material</b>	<b>Body</b> Aluminium <b>Diff</b> Transparent Glass
<b>Power</b>	2x3W
<b>Lumen Output</b>	2x100lm
<b>Light Source</b>	COB LED 3000K
<b>Class</b>	I
<b>CRI</b>	>80
<b>Voltage (V/Hz)</b>	110V/50-60Hz

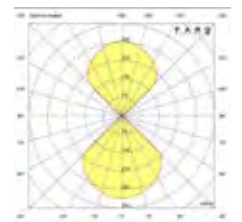
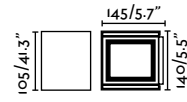
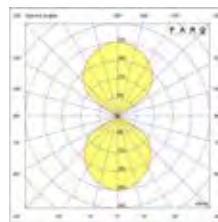
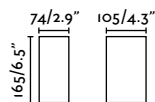
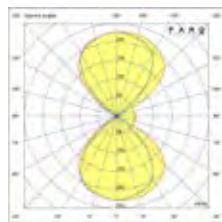
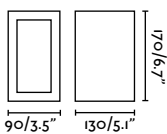

outdoor

Surface



Log 70264-110



Olan 70637-110



All these products have flaps on both sides and can be adjusted independently by changing the angle.

## Nairobi

IP54 IK06 incl.



70832 ● Rust Brown

<b>Material</b>	Body Aluminium Diff Transparent Glass
<b>Power</b>	6W
<b>Lumen Output</b>	380lm
<b>Light Source</b>	COB LED 3000K
<b>Class</b>	I
<b>CRI</b>	>80
<b>Voltage (V/Hz)</b>	100V-240V/50-60Hz

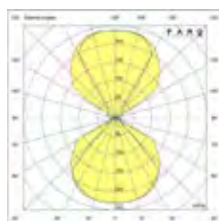
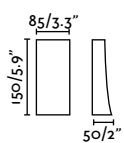

## Sunset

IP54 incl.



70686-110 ● Matt White  
70687-110 ● Dark Grey

<b>Material</b>	Body Aluminium Diff Opal Glass
<b>Power</b>	2x3W
<b>Lumen Output</b>	2x130lm
<b>Light Source</b>	SMD LED 3000K
<b>Class</b>	I
<b>CRI</b>	>80
<b>Voltage (V/Hz)</b>	110V/50-60Hz

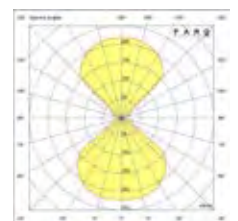
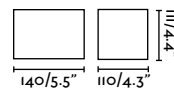

outdoor

Surface



Sunset 70686-110



Nairobi 70832



Flaps on both sides and can be adjusted independently by changing the angle.



## Tinia

IP44



71353 ● Dark Grey

<b>Material</b>	<b>Body</b> Aluminium
	<b>Diff</b> Opal PC
<b>Light Source</b>	1 E27 max. 15W
<b>Bulb incl.</b>	No
<b>Class</b>	I

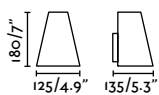

## Gina

IP44



71363 ● Dark Grey  
71366 ● Matt White  
71367 ● Matt Black

<b>Material</b>	<b>Body</b> Aluminium
	<b>Diff</b> Transparent Glass
<b>Light Source</b>	1 GU10 max. 8W
<b>Bulb incl.</b>	No
<b>Class</b>	I

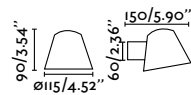

outdoor

Surface



Ele

IP54  incl.



74419

● Dark Grey

<b>Material</b>	<b>Body</b> Aluminium
	<b>Diff</b> Opal PC
<b>Power</b>	6W
<b>Lumen Output</b>	450lm
<b>Light Source</b>	SMD LED 3000K
<b>Class</b>	I
<b>CRI</b>	>80
<b>Voltage (V/Hz)</b>	100V-240V/50-60Hz
<b>Beam angle</b>	95°

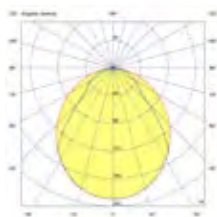
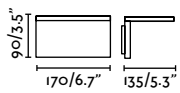

outdoor

Surface



Ele 74419



**Proa**  
Àlex & Manel Llusçà

IP44



74400

● Dark Grey

<b>Material</b>	<b>Body</b> Aluminium
	<b>Diff</b> Transparent Glass
<b>Light Source</b>	1 GU10 max. 8W
<b>Bulb incl.</b>	No
<b>Class</b>	I

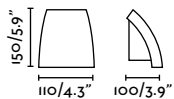



**Steps 2L**  
Estudi Ribaudí

IP44 IK06



- 75500  Matt White
- 75501  Dark Grey

<b>Material</b>	<b>Body</b> Aluminium
	<b>Diff</b> Transparent Glass
<b>Light Source</b>	2 GU10 max. 8W
<b>Bulb incl.</b>	No
<b>Class</b>	I

**Steps 4L**  
Estudi Ribaudí

IP44



- 75502  Matt White
- 75503  Dark Grey

<b>Material</b>	<b>Body</b> Aluminium
	<b>Diff</b> Transparent Glass
<b>Light Source</b>	4 GU10 max. 8W
<b>Bulb incl.</b>	No
<b>Class</b>	I

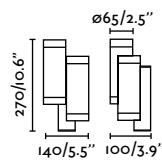
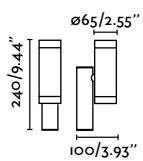

# Steps

Design Estudi Ribaudí



Steps 2L 75500





**Klamp 1L**  
Àlex & Manel Llusçà

IP44



74407 ● Dark Grey

<b>Material</b>	<b>Body</b> Aluminium
	<b>Diff</b> Transparent Glass
<b>Light Source</b>	1 GU10 max. 8W
<b>Bulb incl.</b>	No
<b>Class</b>	I

**Klamp 2L**  
Àlex & Manel Llusçà

IP44



74408 ● Dark Grey

<b>Material</b>	<b>Body</b> Aluminium
	<b>Diff</b> Transparent Glass
<b>Light Source</b>	2 GU10 max. 8W
<b>Bulb incl.</b>	No
<b>Class</b>	I

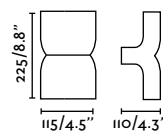
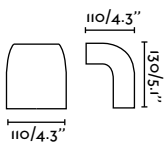

outdoor

Surface

# Klamp

**Design** Àlex & Manel Llusçà

Modern and robust line design. Made of injected aluminium and polycarbonate diffuser



Klamp 1L 74407

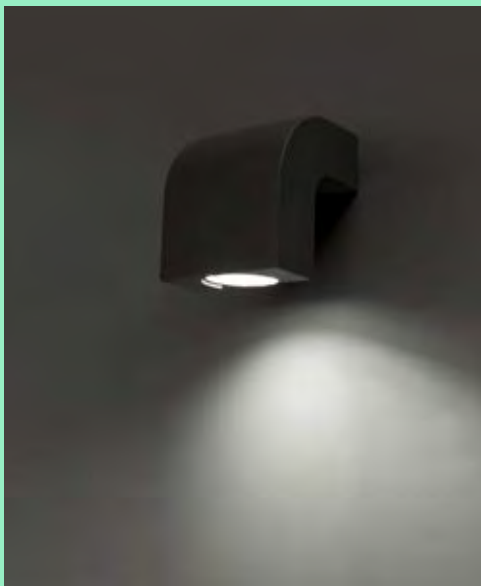

Klamp 2L 74408

# Pill

IP54 IK06 incl.



- 70824  Matt White
- 70825  Dark Grey
- 70826  Rust Brown

<b>Material</b>	<b>Body</b> Aluminium <b>Diff</b> Opal Glass
<b>Power</b>	3,5W
<b>Lumen Output</b>	110lm
<b>Light Source</b>	COB LED 3000K
<b>Class</b>	I
<b>CRI</b>	>80
<b>Voltage (V/Hz)</b>	100V-240V/50-60Hz

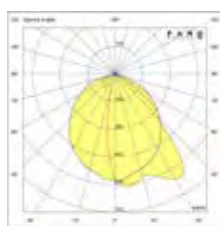
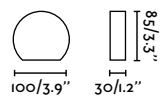

outdoor

Surface





## Loth 1L

IP67 IK10 incl.



70285-110 ● Matt Black

<b>Material</b>	<b>Body Aluminium</b>
	<b>Diff Opal PC</b>
<b>Power</b>	6W
<b>Lumen Output</b>	210lm
<b>Light Source</b>	COB LED 3000K
<b>Class</b>	I
<b>CRI</b>	>80
<b>Voltage (V/Hz)</b>	110V/50-60Hz
<b>Resistance (Kg)</b>	2000Kg

## Loth 2L

IP67 IK10 incl.



70286-110 ● Matt Black

<b>Material</b>	<b>Body Aluminium</b>
	<b>Diff Opal PC</b>
<b>Power</b>	11,5W
<b>Lumen Output</b>	406lm
<b>Light Source</b>	COB LED 3000K
<b>Class</b>	I
<b>CRI</b>	>80
<b>Voltage (V/Hz)</b>	110V/50-60Hz
<b>Resistance (Kg)</b>	2000Kg

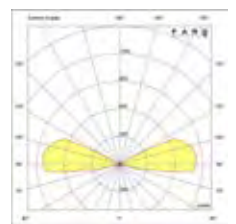
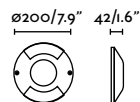
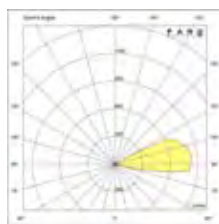
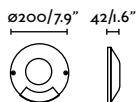



Loth 1L 70285-110



Loth 2L 70286-110

### Keenan 1

IP67

IK08



SEA SIDE  
SUITABLE



70546

● Matt Nickel

<b>Material</b>	<b>Body</b> Aluminium
	<b>Diff</b> Transparent PC
<b>Power</b>	0,5W
<b>Lumen Output</b>	20lm
<b>Light Source</b>	SMD LED 6500K
<b>Class</b>	III
<b>CRI</b>	>80
<b>Voltage (V/Hz)</b>	12V DC

### Keenan 2

IP67

IK08



SEA SIDE  
SUITABLE



70547

● Matt Nickel

<b>Material</b>	<b>Body</b> Aluminium
	<b>Diff</b> Transparent PC
<b>Power</b>	0,8W
<b>Lumen Output</b>	40lm
<b>Light Source</b>	SMD LED 6500K
<b>Class</b>	III
<b>CRI</b>	>80
<b>Voltage (V/Hz)</b>	12V DC

### Keenan 4

IP67

IK08



SEA SIDE  
SUITABLE



70564

● Matt Nickel

<b>Material</b>	<b>Body</b> Aluminium
	<b>Diff</b> Transparent PC
<b>Power</b>	1W
<b>Lumen Output</b>	80lm
<b>Light Source</b>	SMD LED 6500K
<b>Class</b>	III
<b>CRI</b>	>80
<b>Voltage (V/Hz)</b>	12V DC

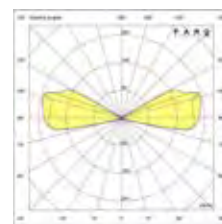
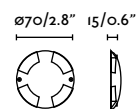
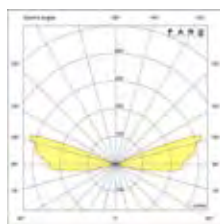
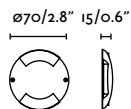
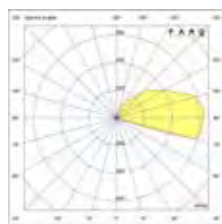
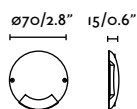



Keenan 1 70546

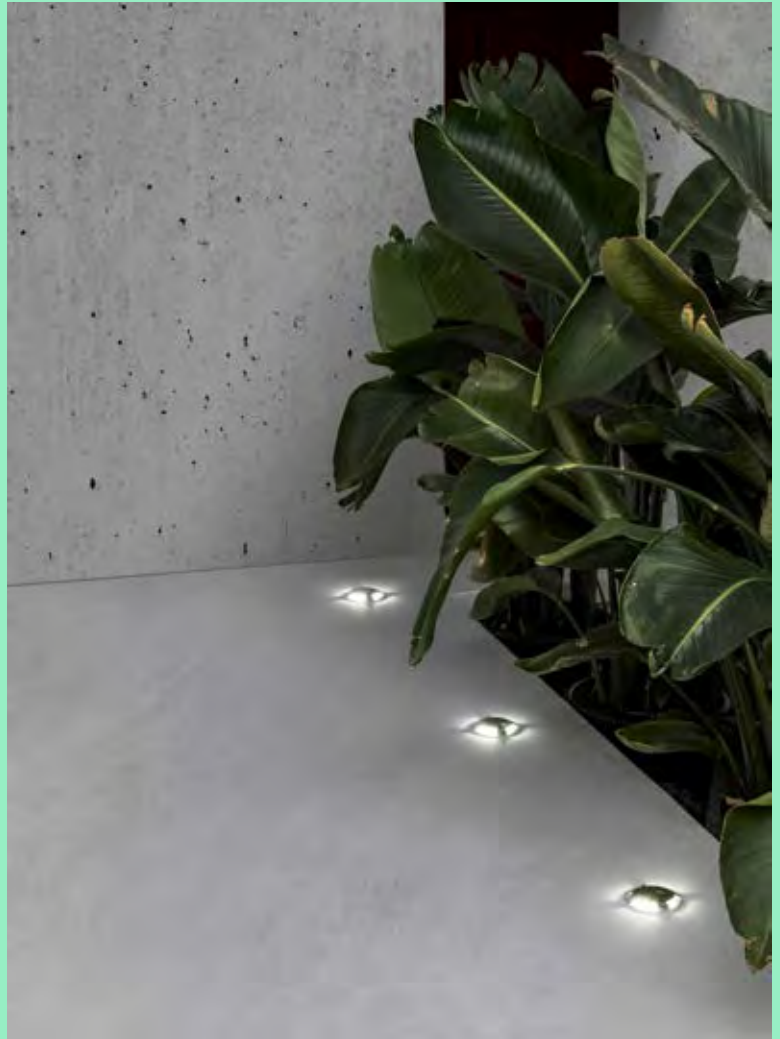

Keenan 4 70564



## Grant SQ

IP65 IK10 incl. SEA SIDE SUITABLE



70655

● Dark Grey

<b>Material</b>	<b>Body ABS</b>
	<b>Diff Transparent PC</b>
<b>Power</b>	1W
<b>Lumen Output</b>	65lm
<b>Light Source</b>	SMD LED 3000K
<b>Class</b>	II
<b>CRI</b>	>80
<b>Voltage (V/Hz)</b>	100V-240V/50-60Hz
<b>Beam angle</b>	120°

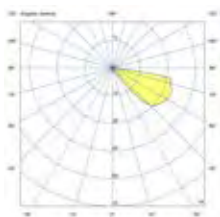
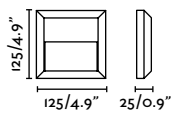

## Grant R

IP65 IK10 incl. SEA SIDE SUITABLE



70656

● Dark Grey

<b>Material</b>	<b>Body ABS</b>
	<b>Diff Transparent PC</b>
<b>Power</b>	1W
<b>Lumen Output</b>	65lm
<b>Light Source</b>	SMD LED 3000K
<b>Class</b>	II
<b>CRI</b>	>80
<b>Voltage (V/Hz)</b>	100V-240V/50-60Hz
<b>Beam angle</b>	120°

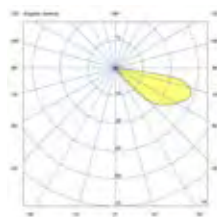
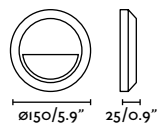

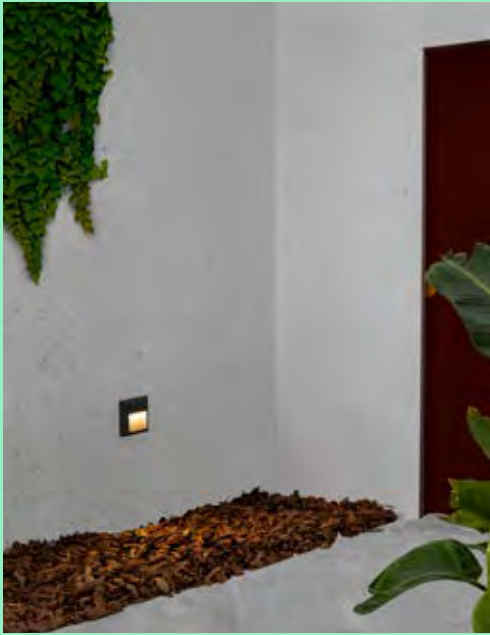

Tom 190 70665



Grant R 70656



# RECESSED



Geiser is FARO's most complete family of outdoor recessed lights. It includes versions with integrated LED and models compatible with GU10 lamps.

The family is available in 4 sizes, each with a recessed optical block that, combined with the honeycomb, provides exceptional glare control.



Geiser 180  
70309

outdoor

Recessed



Geiser 130 70302-110

Geiser 130  
70303-110

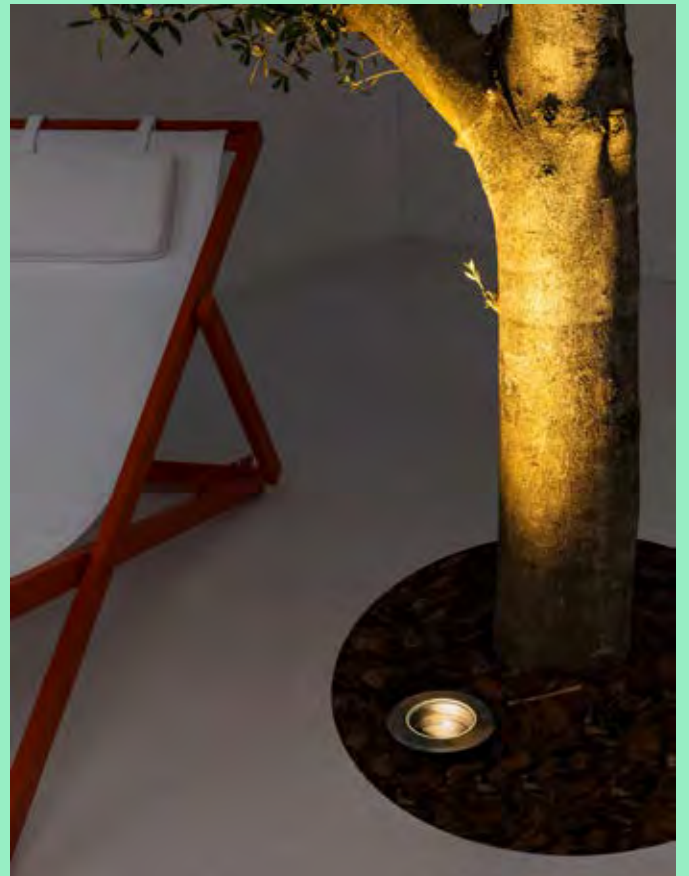

## Geiser 130 ceiling

IP67 IK08 incl. SEA SIDE SUITABLE no incl.



70305-110 ● Satin Stainless

<b>Material</b>	<b>Body</b> Stainless steel 316L+Aluminium
	<b>Diff</b> Transparent Glass
<b>Power</b>	6,5W
<b>Lumen Output</b>	400lm
<b>Light Source</b>	COB LED 3000K
<b>Class</b>	I
<b>CRI</b>	>80
<b>Voltage (V/Hz)</b>	110V/50-60Hz
<b>Beam angle</b>	38°
<b>Cut out</b>	ø116

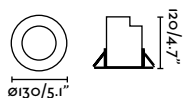

## Geiser 130 GU10 Ceiling

IP67 IK08 SEA SIDE SUITABLE 40° no incl.



70304 ● Satin Stainless

<b>Material</b>	<b>Body</b> Stainless steel 316L+Aluminium
	<b>Diff</b> Transparent Glass
<b>Light Source</b>	1 GU10 max. 8W
<b>Bulb incl.</b>	No
<b>Class</b>	I
<b>Cut out</b>	ø116

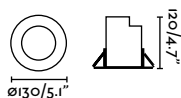

## Geiser 130

IP67 IK08 incl. SEA SIDE SUITABLE 20° incl.



- 70302-110 10° ●● Satin Stainless + Matt Black
- 70303-110 38° ●● Satin Stainless + Matt Black

<b>Material</b>	<b>Body</b> Stainless steel 316L+Aluminium
	<b>Diff</b> Transparent Glass
<b>Power</b>	6,5W
<b>Lumen Output</b>	400lm
<b>Light Source</b>	COB LED 3000K
<b>Class</b>	I
<b>CRI</b>	>80
<b>Voltage (V/Hz)</b>	110V/50-60Hz
<b>Cut out</b>	ø90
<b>Resistance (Kg)</b>	2000Kg

## Geiser 180

IP67 IK08 incl. SEA SIDE SUITABLE 25° 25° incl.



- 70308 10° ● Satin Stainless
- 70309 38° ● Satin Stainless

<b>Material</b>	<b>Body</b> Stainless steel 316L+Aluminium
	<b>Diff</b> Transparent Glass
<b>Power</b>	12,5W
<b>Lumen Output</b>	1400lm
<b>Light Source</b>	COB LED 3000K
<b>Class</b>	I
<b>CRI</b>	>80
<b>Voltage (V/Hz)</b>	100V-240V/50-60Hz
<b>Cut out</b>	ø165
<b>Resistance (Kg)</b>	2000Kg

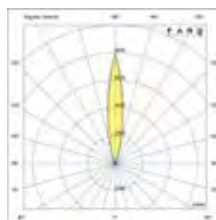

10°

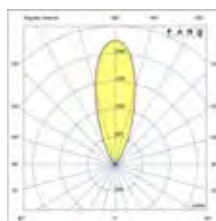

38°

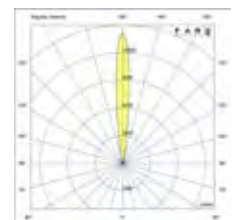
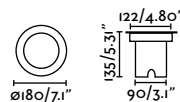
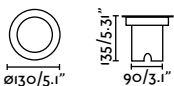

10°

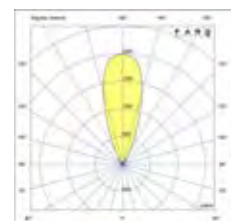

38°



## Geiser 130 GU10

IP67 IK08 SEA SIDE SUITABLE 25° 25° incl.



70310

● Satin Stainless

<b>Material</b>	<b>Body</b> Stainless steel 316L+Aluminium
	<b>Diff</b> Transparent Glass
<b>Light Source</b>	1 GU10 max. 8W
<b>Bulb incl.</b>	No
<b>Class</b>	I
<b>Cut out</b>	ø120
<b>Resistance (Kg)</b>	2000Kg

## Geiser 260

IP67 IK08 incl. SEA SIDE SUITABLE 20° incl.



70306 10°

●● Satin Stainless + Matt Black

70307 38°

●● Satin Stainless + Matt Black

<b>Material</b>	<b>Body</b> Stainless steel 316L+Aluminium
	<b>Diff</b> Transparent Glass
<b>Power</b>	29W
<b>Lumen Output</b>	1800 lm
<b>Light Source</b>	COB LED 3000K
<b>Class</b>	I
<b>CRI</b>	>80
<b>Voltage (V/Hz)</b>	100V-240V/50-60Hz
<b>Cut out</b>	ø200
<b>Resistance (Kg)</b>	2000Kg

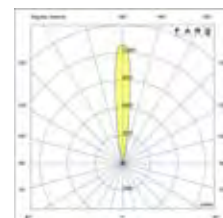

10°

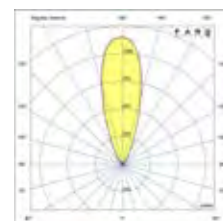

38°

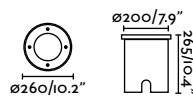
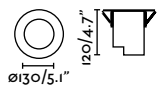

Geiser's orientation system is not only accurate, but also allows the orientation to be adjusted once the product is already installed, providing the flexibility to verify and adjust the desired effect during orientation, ensuring an optimal result tailored to specific needs.

# Grund

Grund stands out as an elegant and robust option, especially designed for applications where product integration with the architecture is key.

The built-in bee panel provides exceptional glare control, enhancing the visual experience.



Grund 80 70731



outdoor

Recessed



Grund 92  
70732

Grund 80  
70731





### Grund 37

IP67 IK08 no incl. SEA SIDE SUITABLE  
incl. 



- 70726 ● Satin Stainless
- 70730 ● Anodized Black

<b>Material</b>	Body Stainless steel 316L+Aluminium Diff Transparent Glass
<b>Power</b>	2W
<b>Lumen Output</b>	152lm
<b>Light Source</b>	SMD LED 3000K
<b>Class</b>	III
<b>CRI</b>	>90
<b>Beam angle</b>	15°
<b>Cut out</b>	ø32
<b>Resistance (Kg)</b>	1000Kg

### Grund 80

IP67 IK08 no incl. SEA SIDE SUITABLE  
incl. 



- 70728 ● Satin Stainless
- 70731 ● Anodized Black

<b>Material</b>	Body Stainless steel 316L+Aluminium Diff Transparent Glass
<b>Power</b>	7W
<b>Lumen Output</b>	420lm
<b>Light Source</b>	COB LED 3000K
<b>Class</b>	III
<b>CRI</b>	>90
<b>Beam angle</b>	36°
<b>Cut out</b>	ø60
<b>Resistance (Kg)</b>	1000Kg

### Grund 92

IP67 IK08 no incl. SEA SIDE SUITABLE  
incl. 



- 70729 ● Satin Stainless
- 70732 ● Anodized Black

<b>Material</b>	Body Stainless steel 316L+Aluminium Diff Transparent Glass
<b>Power</b>	13W
<b>Lumen Output</b>	846lm
<b>Light Source</b>	COB LED 3000K
<b>Class</b>	III
<b>CRI</b>	>90
<b>Beam angle</b>	36°
<b>Cut out</b>	ø68
<b>Resistance (Kg)</b>	1000Kg

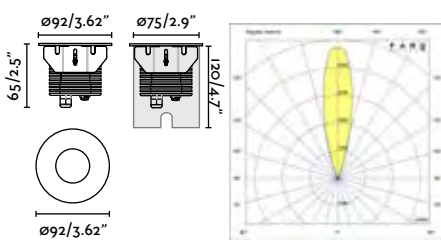
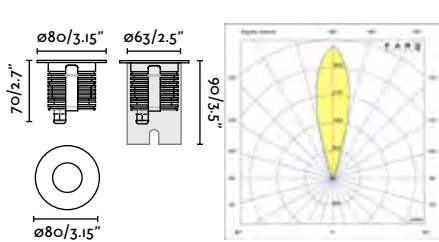
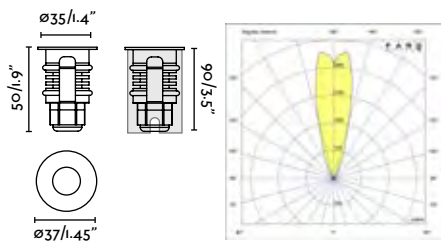

outdoor

Recessed



Grund 80 70731

951

## Grund 37

IP67 IK08 no incl. SEA SIDE SUITABLE incl.



- 70733 ● Satin Aluminium
- 70735 ● Anodized Black

<b>Material</b>	<b>Body</b> Stainless steel 316L+Aluminium
	<b>Diff</b> Transparent Glass
<b>Power</b>	2W
<b>Light Source</b>	SMD LED 2700K
<b>Class</b>	III
<b>CRI</b>	>90
<b>Beam angle</b>	15°
<b>Cut out</b>	ø32
<b>Resistance (Kg)</b>	1000Kg

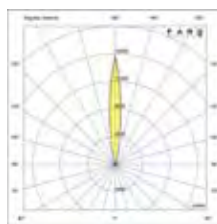
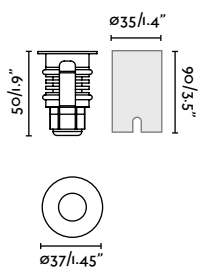

## Grund 80

IP67 IK08 no incl. SEA SIDE SUITABLE incl.



- 70734 ● Satin Aluminium
- 70736 ● Anodized Black

<b>Material</b>	<b>Body</b> Stainless steel 316L+Aluminium
	<b>Diff</b> Transparent Glass
<b>Power</b>	7W
<b>Light Source</b>	COB LED 2700K
<b>Class</b>	III
<b>CRI</b>	>90
<b>Beam angle</b>	36°
<b>Cut out</b>	ø60
<b>Resistance (Kg)</b>	1000Kg

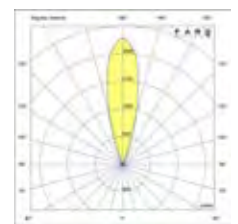
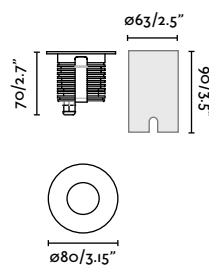

outdoor

Recessed





### Kane 1

IP67 IK08 no incl. SEA SIDE SUITABLE  
incl.



- 70660 3000K ● Satin Stainless
- 70660W 2700K ● Satin Stainless

<b>Material</b>	<b>Body</b> Stainless steel 316L <b>Diff</b> Opal Glass
<b>Power</b>	3W
<b>Lumen Output</b>	120lm
<b>Light Source</b>	COB LED
<b>Class</b>	III
<b>CRI</b>	>80
<b>Voltage (V/Hz)</b>	24V DC/50-60Hz
<b>Beam angle</b>	120°
<b>Cut out</b>	ø40
<b>Resistance (Kg)</b>	1000Kg

### Kane 2

IP67 IK08 no incl. SEA SIDE SUITABLE  
incl.



- 70661 3000K ● Satin Stainless
- 70661W 2700K ● Satin Stainless

<b>Material</b>	<b>Body</b> Stainless steel 316L <b>Diff</b> Opal Glass
<b>Power</b>	3W
<b>Lumen Output</b>	120lm
<b>Light Source</b>	COB LED
<b>Class</b>	III
<b>CRI</b>	>80
<b>Voltage (V/Hz)</b>	24V DC/50-60Hz
<b>Beam angle</b>	120°
<b>Cut out</b>	ø40
<b>Resistance (Kg)</b>	1000Kg

### Kane 3

IP67 IK08 no incl. SEA SIDE SUITABLE  
incl.



- 70662 3000K ● Satin Stainless
- 70662W 2700K ● Satin Stainless

<b>Material</b>	<b>Body</b> Stainless steel 316L <b>Diff</b> Opal Glass
<b>Power</b>	3W
<b>Lumen Output</b>	120lm
<b>Light Source</b>	COB LED
<b>Class</b>	III
<b>CRI</b>	>80
<b>Voltage (V/Hz)</b>	24V DC/50-60Hz
<b>Beam angle</b>	120°
<b>Cut out</b>	ø40
<b>Resistance (Kg)</b>	1000Kg

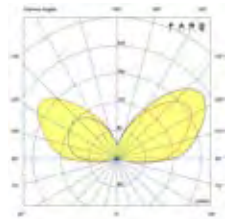
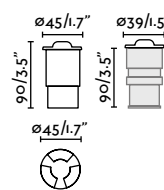
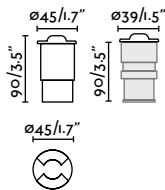
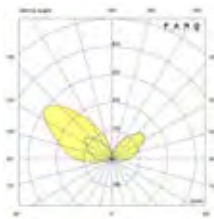
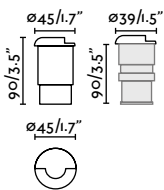

# Kane

Kane is a family of recessed signage that stands out for its reduced dimensions, durability and robustness. With three versions of light output, it is an elegant and comfortable solution for delimiting or signaling transit areas.

## Crosby

IP67 IK08 incl. SEA SIDE SUITABLE incl.



70459N ● Satin Stainless

<b>Material</b>	Body Stainless steel 316L+Aluminium Diff Opal Glass
<b>Power</b>	1W
<b>Lumen Output</b>	13lm
<b>Light Source</b>	SMD LED 3000K
<b>Class</b>	I
<b>CRI</b>	>80
<b>Voltage (V/Hz)</b>	120V-240V/50-60Hz
<b>Beam angle</b>	120°
<b>Cut out</b>	ø80

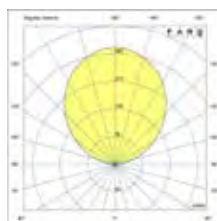
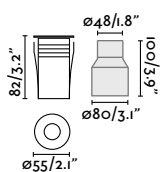

## Crosby 24V

IP67 IK08 no incl. SEA SIDE SUITABLE incl.



70453 ● Satin Stainless

<b>Material</b>	Body Stainless steel 316L+Aluminium Diff Opal Glass
<b>Power</b>	0,7W
<b>Lumen Output</b>	77lm
<b>Light Source</b>	SMD LED 3000K
<b>Class</b>	III
<b>CRI</b>	>80
<b>Voltage (V/Hz)</b>	24V DC/50-60Hz
<b>Beam angle</b>	120°
<b>Cut out</b>	ø80

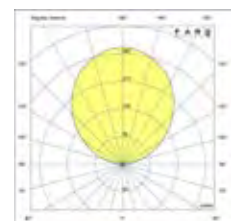
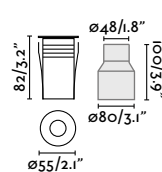



Crosby

outdoor

Recessed



Crosby 70459N

957



## Suria 120

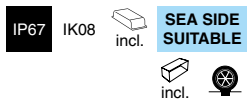

- 70588 24° ● Satin Stainless
- 70592N 60° ● Satin Stainless

<b>Material</b>	<b>Body</b> Stainless steel 316L+Aluminium <b>Diff</b> Transparent Glass
<b>Power</b>	3W
<b>Lumen Output</b>	175lm
<b>Light Source</b>	COB LED 3000K
<b>Class</b>	I
<b>CRI</b>	>80
<b>Voltage (V/Hz)</b>	100V-240V/50-60Hz
<b>Cut out</b>	ø100
<b>Resistance (Kg)</b>	1000Kg

## Suria 180

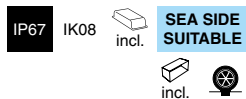

- 70589 24° ● Satin Stainless
- 70593N 60° ● Satin Stainless

<b>Material</b>	<b>Body</b> Stainless steel 316L+Aluminium <b>Diff</b> Transparent Glass
<b>Power</b>	12W
<b>Lumen Output</b>	1280lm
<b>Light Source</b>	COB LED 3000K
<b>Class</b>	I
<b>CRI</b>	>80
<b>Voltage (V/Hz)</b>	100V-240V/50-60Hz
<b>Cut out</b>	ø165
<b>Resistance (Kg)</b>	1000Kg

## Suria 220

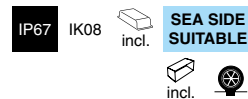

- 70586 24° ● Satin Stainless
- 70587 60° ● Satin Stainless

<b>Material</b>	<b>Body</b> Stainless steel 316L+Aluminium <b>Diff</b> Transparent Glass
<b>Power</b>	24W
<b>Lumen Output</b>	2200lm
<b>Light Source</b>	COB LED 3000K
<b>Class</b>	I
<b>CRI</b>	>80
<b>Voltage (V/Hz)</b>	100V-240V/50-60Hz
<b>Cut out</b>	ø209
<b>Resistance (Kg)</b>	1000Kg

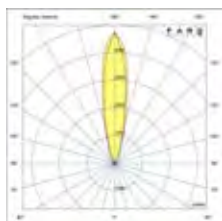

24°

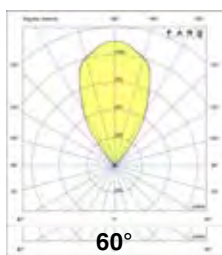

60°

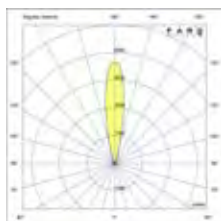
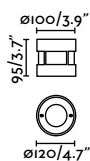

24°

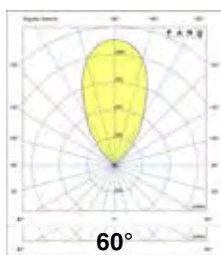

60°

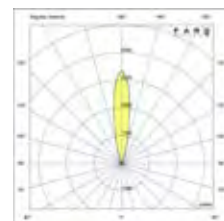
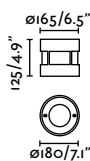

24°

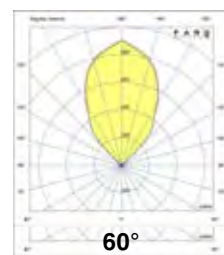

60°

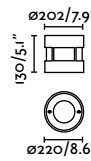

# Suria



Suria 120 70588

Suria offers three different sizes of floor recessed luminaires, each with two fixed optics specifically designed to enhance their versatility. Its glass finish and stainless steel ring, complemented by discreet hardware, make Suria exceptionally robust.



Suria 180 70589

# Salt

IP67 IK08 incl. SEA SIDE SUITABLE incl.



70591 ● Satin Stainless

<b>Material</b>	<b>Body</b> Stainless steel 316L+Aluminium <b>Diff</b> Transparent Glass
<b>Power</b>	9W
<b>Lumen Output</b>	700lm
<b>Light Source</b>	COB LED 3000K
<b>Class</b>	I
<b>CRI</b>	>=90
<b>Voltage (V/Hz)</b>	100V-240V/50-60Hz
<b>Beam angle</b>	45°
<b>Cut out</b>	ø170
<b>Resistance (Kg)</b>	2000Kg

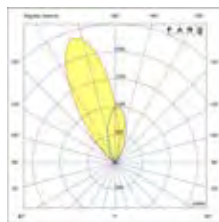
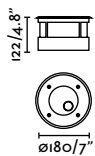

# Salt

outdoor

Recessed



Salt is a recessed luminaire with a circular format and asymmetrical design. It stands out for its light control with a fixed orientation that allows the creation of lighting effects on the wall without generating glare.

Salt 70591

Salt 70591





## Taro

IP67 IK08 incl. SEA SIDE SUITABLE incl.



70449

● Satin Stainless

<b>Material</b>	<b>Body</b> Stainless steel 316L+Aluminium <b>Diff</b> Transparent Glass
<b>Power</b>	7W
<b>Lumen Output</b>	280lm
<b>Light Source</b>	COB LED 3000K
<b>Class</b>	I
<b>CRI</b>	>80
<b>Voltage (V/Hz)</b>	100V-240V/50-60Hz
<b>Beam angle</b>	30°
<b>Cut out</b>	ø90
<b>Resistance (Kg)</b>	600Kg

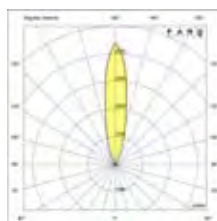
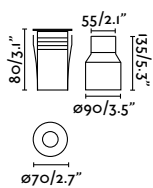

## Tecno

IP67 IK08 incl. SEA SIDE SUITABLE incl.



71489N

● Satin Stainless

<b>Material</b>	<b>Body</b> Stainless steel 316L+Aluminium <b>Diff</b> Transparent Glass
<b>Power</b>	8W
<b>Light Source</b>	GU10
<b>Class</b>	I
<b>Voltage (V/Hz)</b>	100V-240V/50-60Hz
<b>Cut out</b>	ø100
<b>Resistance (Kg)</b>	2000Kg

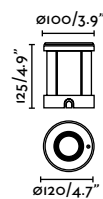



Tecno, with its GU10 option, offers architectural lighting possibilities by allowing optics and color temperatures to be defined with the lamp itself.

## Nok 44

IP68 IK06 no incl. incl. SUB

NEW



70443

● Satin Stainless

<b>Material</b>	<b>Body</b> Stainless steel 316L
	<b>Diff</b> Transparent Glass
<b>Power</b>	3W
<b>Lumen Output</b>	196lm
<b>Light Source</b>	SMD LED 4000K
<b>Class</b>	III
<b>CRI</b>	>80
<b>Voltage (V/Hz)</b>	24V DC
<b>Beam angle</b>	30°
<b>Cut out</b>	ø204

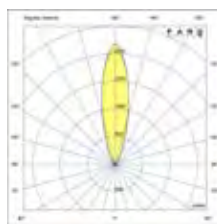
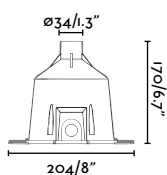
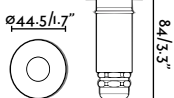

## Nok 68

IP68 IK08 no incl. incl. SUB

NEW



70444

● Satin Stainless

<b>Material</b>	<b>Body</b> Stainless steel 316L
	<b>Diff</b> Transparent Glass
<b>Power</b>	5W
<b>Lumen Output</b>	348lm
<b>Light Source</b>	SMD LED 4000K
<b>Class</b>	III
<b>CRI</b>	>80
<b>Voltage (V/Hz)</b>	24V DC
<b>Beam angle</b>	30°
<b>Cut out</b>	ø230

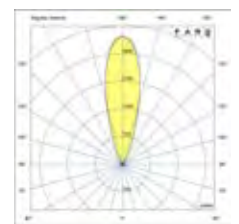
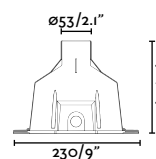
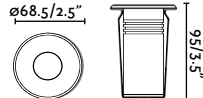



# Nok NEW

Its body made of stainless steel and glass offers a 30-degree exit angle, making it an elegant and subtle option for perimeter lighting and stairs in swimming pools.

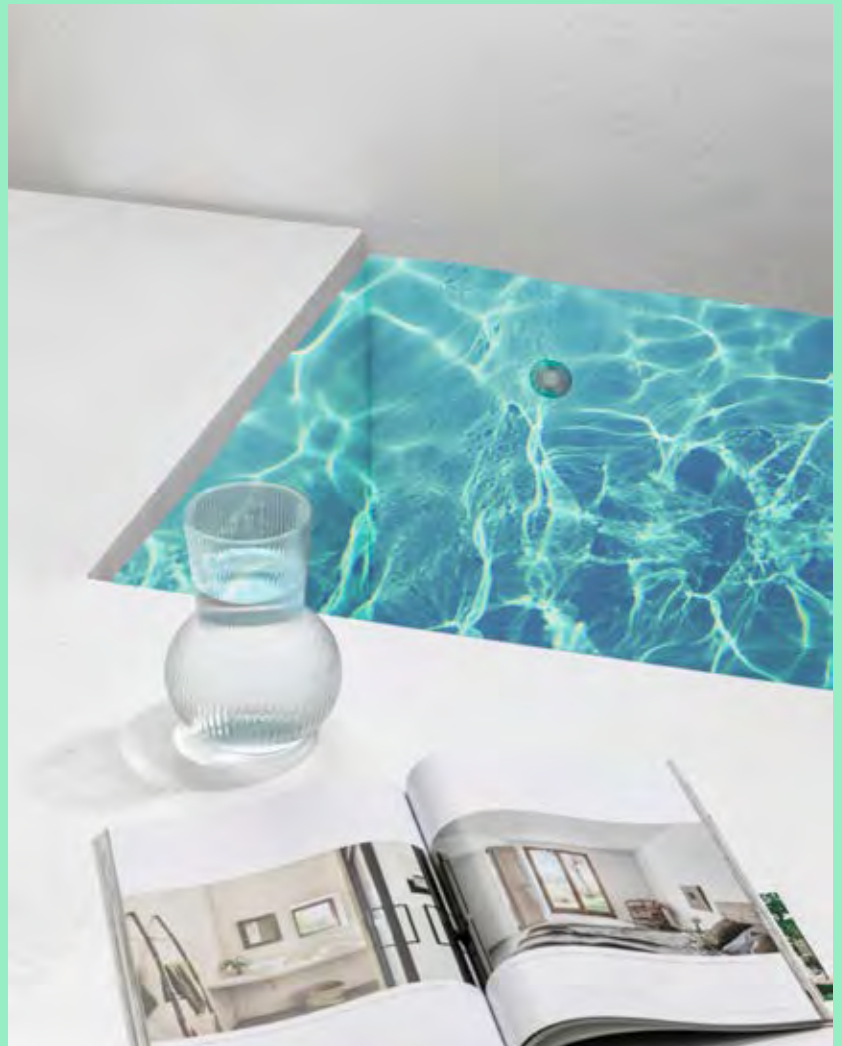

Stainless steel frame, with glass diffuser & 30° optic



It has a recessed box that provides space to leave a length of cable, allowing maintenance without the need to empty the pool.



Edel

IP68 IK08 no incl. incl. SUB



70455 ● Satin Stainless

<b>Material</b>	<b>Body</b> Stainless steel 316L+ABS <b>Diff</b> Opal Glass
<b>Power</b>	18W
<b>Lumen Output</b>	600lm
<b>Light Source</b>	SMD LED 4000K
<b>Class</b>	III
<b>CRI</b>	85
<b>Voltage (V/Hz)</b>	24V DC/50-60Hz
<b>Beam angle</b>	25°
<b>Cut out</b>	ø156

\*Drivers info pag. 1405

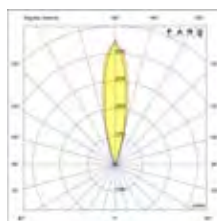
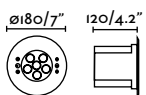

outdoor

Recessed

# Edel

Equipped with a 30-degree optical block, it offers an ideal lighting package for perimeter lighting of pools of all sizes.

## Dang

IP67 IK05 no incl. SEA SIDE SUITABLE incl.



70446 ● Satin Stainless

<b>Material</b>	<b>Body</b> Stainless steel 316L+Glass
	<b>Diff</b> Transparent Glass
<b>Power</b>	3W
<b>Lumen Output</b>	80lm
<b>Light Source</b>	COB LED 3000K
<b>Class</b>	III
<b>CRI</b>	>80
<b>Voltage (V/Hz)</b>	24V DC/50-60Hz
<b>Beam angle</b>	40°
<b>Cut out</b>	ø88

## Spark

IP65 IK10 incl. incl.



70162-110 ● Dark Grey

70163-110 ● Matt White

<b>Material</b>	<b>Body</b> Aluminium
	<b>Diff</b> Opal PC
<b>Power</b>	5W
<b>Lumen Output</b>	230lm
<b>Light Source</b>	SMD LED 3000K
<b>Class</b>	I
<b>CRI</b>	>80
<b>Voltage (V/Hz)</b>	110V/50-60Hz
<b>Cut out</b>	95x65

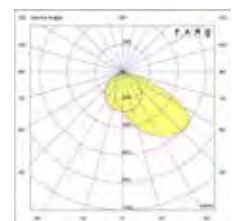
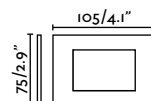
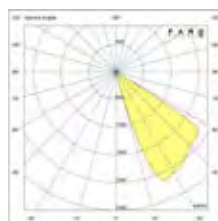
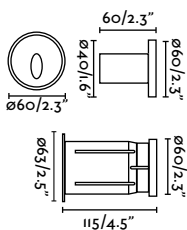

\*Drivers info pag. 1405

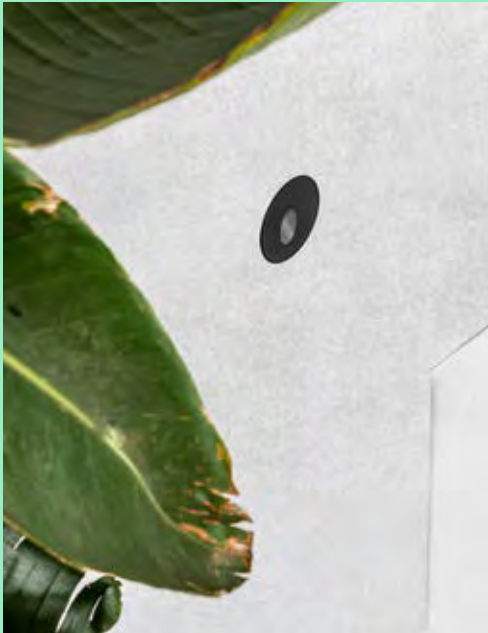

Dang 70446

These recessed LED wall lights, available in matte white and dark gray colors, are ideal for outdoor signage lighting. With an IP65 protection rating, they offer high resistance against rain and solid bodies, making them a robust choice for outdoor environments.



Spark 70162



## Soun 105

IP65 IK06  
incl. incl.



70833 ● Dark Grey  
70834 ● Matt White

<b>Material</b>	<b>Body</b> Aluminium <b>Diff</b> Transparent Glass
<b>Power</b>	4,5W
<b>Lumen Output</b>	280lm
<b>Light Source</b>	SMD LED 3000K
<b>Class</b>	I
<b>CRI</b>	>80
<b>Voltage (V/Hz)</b>	100V-240V/50-60Hz
<b>Beam angle</b>	120°
<b>Cut out</b>	220x95

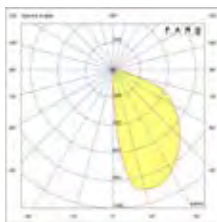
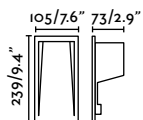

## Soun 193

IP65 IK06  
incl. incl.



70900 ● Dark Grey  
70901 ● Matt White

<b>Material</b>	<b>Body</b> Aluminium <b>Diff</b> Transparent Glass
<b>Power</b>	8W
<b>Lumen Output</b>	630lm
<b>Light Source</b>	SMD LED 3000K
<b>Class</b>	I
<b>CRI</b>	>80
<b>Voltage (V/Hz)</b>	100V-240V/50-60Hz
<b>Beam angle</b>	120°
<b>Cut out</b>	183x225

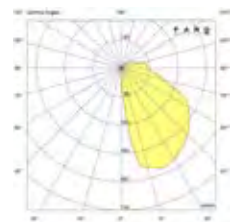
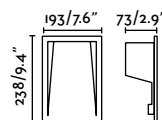

# Soun



Its generous size and die-cast aluminum design make it extremely robust, making it ideal for outdoor applications.

With Soun, a perfect combination of functionality and resistance is achieved, ensuring effective and durable lighting in outdoor environments.



Soun 105 70834

## Sedna SQ 90

IP65 IK06 incl. incl.



70146

● Dark Grey

<b>Material</b>	<b>Body</b> Aluminium
	<b>Diff</b> Opal PC
<b>Power</b>	1W
<b>Lumen Output</b>	30lm
<b>Light Source</b>	SMD LED 3000K
<b>Class</b>	I
<b>CRI</b>	>80
<b>Voltage (V/Hz)</b>	100V-240V/50-60Hz
<b>Beam angle</b>	70°
<b>Cut out</b>	80x75

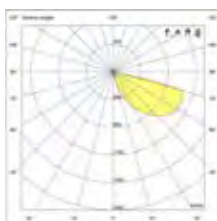
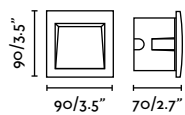

# Sedna

outdoor

Recessed

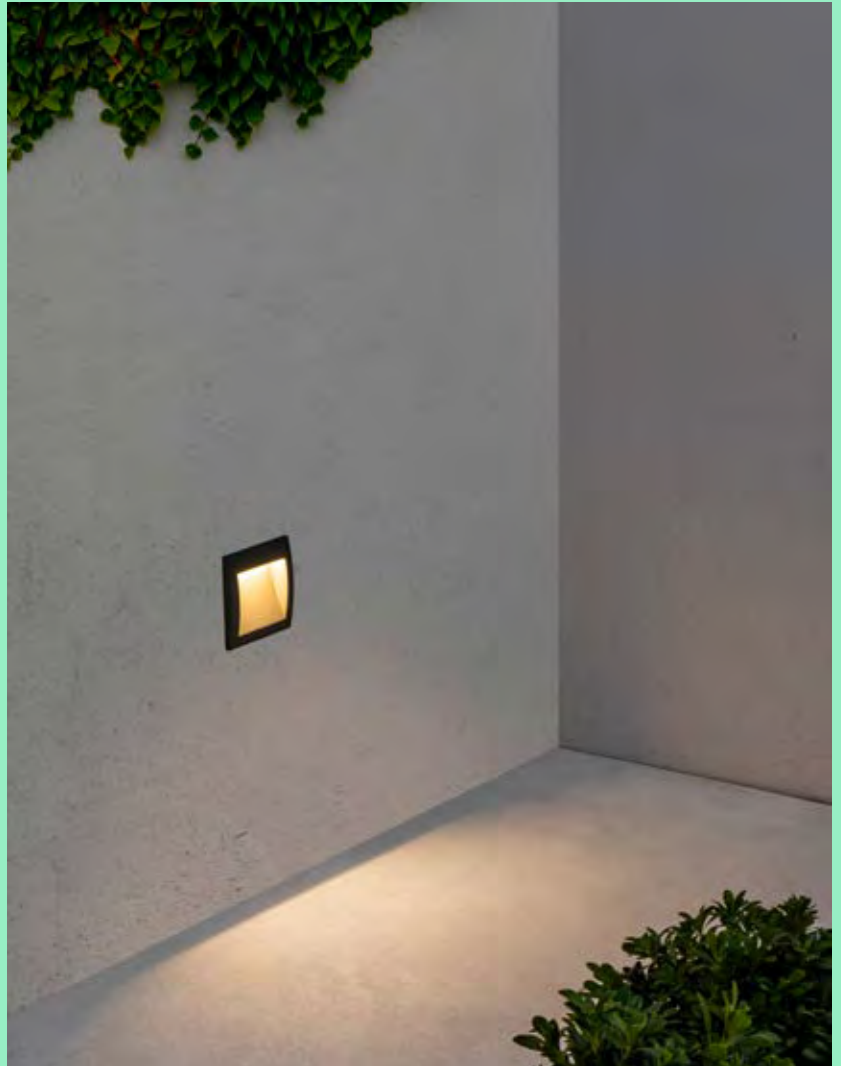

Sedna SQ 140 70148



Available in two formats, square and rectangular, it brings both functionality and aesthetics to outdoor spaces where specific and quality lighting is required.

Sedna is an outdoor recessed designed for signage. Its slightly curved design, together with its high IP protection rating and die-cast aluminum construction, makes it an excellent choice for low-power signage lighting.



## Stripe grid

IP54 IK07 incl.



- 72094  Matt White
- 72095  Dark Grey

<b>Material</b>	<b>Body</b> Aluminium
	<b>Diff</b> Opal PC
<b>Power</b>	5W
<b>Lumen Output</b>	70lm
<b>Light Source</b>	SMD LED 3000K
<b>Class</b>	I
<b>CRI</b>	>80
<b>Voltage (V/Hz)</b>	100V-240V/50-60Hz
<b>Cut out</b>	230x89

## Stripe

IP54 IK07 incl. incl.



- 72092  Dark Grey
- 72093  Matt White

<b>Material</b>	<b>Body</b> Aluminium
	<b>Diff</b> Opal PC
<b>Power</b>	5W
<b>Lumen Output</b>	50lm
<b>Light Source</b>	SMD LED 3000K
<b>Class</b>	I
<b>CRI</b>	>80
<b>Voltage (V/Hz)</b>	100V-240V/50-60Hz
<b>Cut out</b>	230x89

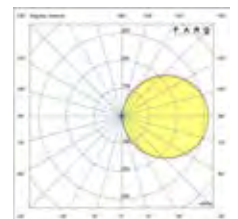
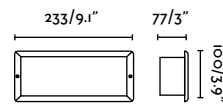
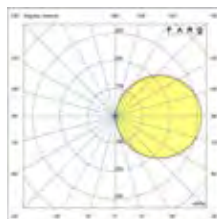
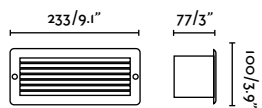

outdoor

Recessed

# Stripe

Both variants are an excellent choice for lighting perimeter areas where a simple and functional luminaire is required.



## Liso

IP44 IK08  no incl.



- 71490  Matt White
- 71491  Matt Black

<b>Material</b>	<b>Body</b> Aluminium
	<b>Diff</b> Opal Glass
<b>Light Source</b>	1 E27 max. 15W
<b>Bulb incl.</b>	No
<b>Class</b>	I
<b>Cut out</b>	230x89

Recessed box	
71482	
<b>Material</b>	<b>Body</b> PVC

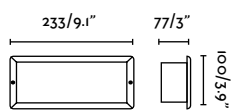

## Esca

IP44  no incl.



- 71480  Matt White
- 71481  Matt Black

<b>Material</b>	<b>Body</b> Aluminium
	<b>Diff</b> Opal Glass
<b>Light Source</b>	1 E27 max. 15W
<b>Bulb incl.</b>	No
<b>Class</b>	I
<b>Cut out</b>	230x89

Recessed box	
71482	
<b>Material</b>	<b>Body</b> PVC

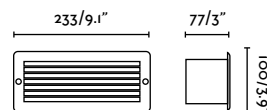



Liso and Esca, offers a convenient option with replaceable lamp, allowing the flexibility to easily select and modify both wattage and color temperature according to the chosen lamp.







**DATA**

## Indoor Drivers

		mA	P	V	units	System	Driver
FOX 3W	02101001 02101002	350mA	3W	220/240V	1-5 units	on/off	98310136
				220/240V	2-3 units	triac	98310110LC
				220/240V	1-5 units	dali	98310136D
				220/240V	2-5 units	casambi	98310538
FOX 5W	02101001 02101002	500mA	5W	220/240V	1-4 units	on/off	98310336
				220/240V	2-4 units	triac	98310321LC
				220/240V	1-5 units	dali	98310336D
				220/240V	1-5 units	casambi	98310538
FOX TRIMLESS 3W	02101101 02101102	350mA	3W	220/240V	1-5 units	on/off	98310136
				220/240V	2-3 units	triac	98310110LC
				220/240V	1-5 units	dali	98310136D
				220/240V	2-5 units	casambi	98310538
FOX TRIMLESS 5W	02101101 02101102	500mA	5W	220/240V	1-4 units	on/off	98310336
				220/240V	2-4 units	triac	98310321LC
				220/240V	1-5 units	dali	98310336D
				220/240V	1-5 units	casambi	98310538
FOX ORIENT-ABLE 3W	02101301 02101302	350mA	3W	220/240V	1-5 units	on/off	98310136
				220/240V	2-3 units	triac	98310110LC
				220/240V	1-5 units	dali	98310136D
				220/240V	2-5 units	casambi	98310538
FOX ORIENT-ABLE 5W	02101301 02101302	500mA	5W	220/240V	1-4 units	on/off	98310336
				220/240V	2-4 units	triac	98310321LC
				220/240V	1-5 units	dali	98310336D
				220/240V	1-5 units	casambi	98310538
FOX 7W	02101501	350mA	7W	220/240V	1-2 units	on/off	98310136
				220/240V	2 units	triac	98310118LC
				220/240V	1-2 units	dali	98310136D
				220/240V	2 units	casambi	98310538
FOX 10W	02101601	500mA	10W	220/240V	1-2 units	on/off	98310336
				220/240V	2 units	triac	98310321LC
				220/240V	2 units	dali	98310336D
				220/240V	2 units	casambi	98310538
AIM 3W	02100401	350mA	3W	220/240V	1-5 units	on/off	98310136
				220/240V	2-3 units	triac	98310110LC
				220/240V	1-5 units	dali	98310136D
				220/240V	2-5 units	casambi	98310538
CLEAR 7W	02100301	350mA	7W	220/240V	1-2 units	on/off	98310136
				220/240V	2 units	triac	98310118LC
				220/240V	1-2 units	dali	98310136D
				220/240V	2 units	casambi	98310538
BOW 3W	02150101	350mA	3W	220/240V	1-5 units	on/off	98310136
				220/240V	2-3 units	triac	98310110LC
				220/240V	1-5 units	dali	98310136D
				220/240V	2-5 units	casambi	98310538
BOW 10W	02150201	350mA	10W	220/240V	1-2 units	on/off	98310136
				220/240V	1-2 units	triac	98310118LC
				220/240V	1-2 units	dali	98310136D
				220/240V	1-2 units	casambi	98310538
BOW 18W	02150301	350mA	18W	220/240V	only 1 unit	on/off	98310136
				220/240V	only 1 unit	triac	98310110LC
				220/240V	only 1 unit	dali	98310136D
				220/240V	only 1 unit	casambi	98310538
PLAS 1W	63281 63282 63283	350mA	1W	220/240V	only 1 unit	on/off	98310103
				220/240V	2-3 units	triac	98310110LC
				220/240V	5-17 units	dali	98310136D
				220/240V	5-17 units	casambi	98310538
NAIS ORIENTABLE 7W	02111001 02111002	350mA	7W	220/240V	1-2 units	on/off	98310136
				220/240V	2 units	triac	98310118LC
				220/240V	1-2 units	dali	98310136D
				220/240V	2 units	casambi	98310538

NAIS 7W	02121001 02121002	350mA	7W	220/240V	1-2 units	on/off	98310136
				220/240V	2 units	triac	98310118LC
				220/240V	1-2 units	dali	98310136D
				220/240V	2 units	casambi	98310538
WABI 10W	43900	250mA	10W	220/240V	only 1 unit	triac	98310510C
				220/240V	only 1 unit	on/off	98310136
NORD 18W	63290	350mA	18W	220/240V	only 1 unit	triac	98310118LC
				220/240V	only 1 unit	dali	98310136D
				220/240V	only 1 unit	casambi	98310538
				100/240V	1-2 units	on/off	98310110
SIGNAL 3W	02100101		3W	220/240V	2-3 units	triac	98310110LC
				220/240V	2-6 units	dali	98310536
				220/240V	2-6 units	casambi	98310538

## Outdoor Drivers

		mA	P	V	units	System	IP	Driver
GRUND 2W	70726 70730 70733 70735	700mA	2W	220/240V	1-16 units	on/off	IP20	98310235
				220/240V	2-4 units	triac	IP20	98310210
				220/240V	1-15 units	dali	IP20	98310235D
				220/240V	4-16 units	casambi	IP20	98310538
GRUND 7W	70728 70731 70734 70736	350mA	7W	220/240V	1-2 units	on/off	IP20	98310136
				220/240V	2 units	triac	IP20	98310118LC
				220/240V	1-2 units	dali	IP20	98310136D
				220/240V	2 units	casambi	IP20	98310538
GRUND 13W	70729 70732	350mA	13W	220/240V	only 1 unit	on/off	IP20	98310136
				220/240V	only 1 unit	triac	IP20	98310118LC
				220/240V	only 1 unit	dali	IP20	98310136D
				220/240V	only 1 unit	casambi	IP20	98310538
KANE 3W	70660 70661 70662	24VDC	3W	220/240V	1-30 units	on/off	IP20	98324099
				220/240V	1-3 units	triac	IP20	98311315
				220/240V	1-30 units	dali	IP20	98324100UD
				220/240V	1-30 units	on/off	IP67	98324100
CROSBY 2W	70453	24VDC	2W	220/240V	1-40 units	on/off	IP20	98324099
				220/240V	1-40 units	on/off	IP67	98324100
TRAS 4W	71701	24VDC	4W	220/240V	1-20 units	on/off	IP20	98324099
				220/240V	1-20 units	on/off	IP67	98324100
TRAS 8W	71702	24VDC	8W	220/240V	1-10 units	on/off	IP20	98324099
				220/240V	1-10 units	on/off	IP67	98324100
TRAS 25W	71716 71717	24VDC	25W	220/240V	1-3 units	on/off	IP20	98324099
				220/240V	1-3 units	on/off	IP67	98324100
DANG 3W	70446	24VDC	3W	220/240V	1-30 units	on/off	IP20	98324099
				220/240V	1-30 units	on/off	IP67	98324100
FALLS 6W	71734 71735	24V DC	6W	220/240V	1-15 units	on/off	IP20	98324099
				220/240V	1-2 units	triac	IP20	98311315
				220/240V	1-15 units	dali	IP20	98324100UD
				220/240V	1-15 units	on/off	IP67	98324100
FALLS 12W	71736 71737	24V DC	12W	220/240V	1-7 units	on/off	IP20	98324099
				220/240V	only 1 unit	triac	IP20	98311315
				220/240V	1-7 units	dali	IP20	98324100UD
				220/240V	1-7 units	on/off	IP67	98324100
FALLS ORIENTABLE 8W	71730 71731	24V DC	8W	220/240V	1-10 units	on/off	IP20	98324099
				220/240V	1-2 units	triac	IP20	98311315
				220/240V	1-10 units	dali	IP20	98324100UD
				220/240V	1-10 units	on/off	IP67	98324100
FALLS ORIENTABLE 16W	71732 71733	24V DC	16W	220/240V	1-5 units	on/off	IP20	98324099
				220/240V	only 1 unit	triac	IP20	98311315
				220/240V	1-5 units	dali	IP20	98324100UD
				220/240V	1-5 units	on/off	IP67	98324100
CUCA		24V DC	3W	220/240V	1-30 units	on/off	IP20	98324099
				220/240V	1-5 units	triac	IP20	98311315
				220/240V	1-30 units	dali	IP20	98324100UD
				220/240V	1-30 units	on/off	IP67	98324100
CLAP		24V DC	6W	220/240V	1-15 units	on/off	IP20	98324099
				220/240V	1-2 units	triac	IP20	98311315
				220/240V	1-15 units	dali	IP20	98324100UD
				220/240V	1-15 units	on/off	IP67	98324100



# SHADES

## Wall lamps

	<b>2P0111</b> $\frac{\varnothing 215/8.6''}{\varnothing 190/7.6''}$ 		<b>2P0112</b> $\frac{\varnothing 215/8.6''}{\varnothing 190/7.6''}$ 		<b>2P0113</b> $\frac{\varnothing 215/8.6''}{\varnothing 190/7.6''}$ 
	<b>2P0211</b> $\frac{\varnothing 220/8.6''}{\varnothing 130/5.1''}$ 		<b>2P0212</b> $\frac{\varnothing 220/8.6''}{\varnothing 130/5.1''}$ 		<b>2P0213</b> $\frac{\varnothing 220/8.6''}{\varnothing 130/5.1''}$ 
	<b>2P0411</b> $\frac{190/7.5''}{\varnothing 160/6.3''}$ 		<b>2P0412</b> $\frac{190/7.5''}{\varnothing 160/6.3''}$ 		<b>2P0413</b> $\frac{190/7.5''}{\varnothing 160/6.3''}$ 
	<b>2P0311</b> $\frac{\varnothing 165/6.5''}{\varnothing 130/5.1''}$ 		<b>2P0312</b> $\frac{\varnothing 165/6.5''}{\varnothing 130/5.1''}$ 		<b>2P0313</b> $\frac{\varnothing 165/6.5''}{\varnothing 130/5.1''}$ 
	<b>2P0615</b> $\frac{\varnothing 215/8.6''}{\varnothing 190/7.6''}$ 		<b>2P0616</b> $\frac{\varnothing 215/8.6''}{\varnothing 190/7.6''}$ 		<b>2P0617</b> $\frac{\varnothing 215/8.6''}{\varnothing 190/7.6''}$ 
	<b>2P0710</b> $\frac{\varnothing 210/8.2''}{\varnothing 160/6.3''}$ 		<b>2P0763</b> $\frac{\varnothing 210/8.3''}{\varnothing 120/4.7''}$ 		

# Suspended



**2P0141**



**2P0142**



**2P0143**



**2P0645**

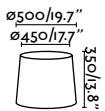

**2P0646**

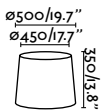

**2P0647**



**2P0710**

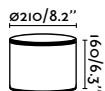

**2P0720**



**2P0730**

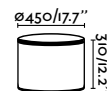

**2P0765**

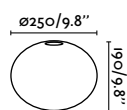

**2P0766**

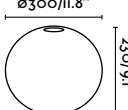

**2P0767**

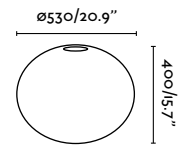

**2P0768**

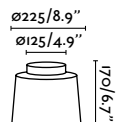

**2P0769**

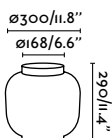

**2P0764**

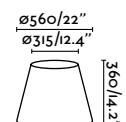

## Table lamps

	<b>2P0121</b> $\frac{\text{ø}250/9.8''}{\text{ø}220/8.6''}$ 		<b>2P0122</b> $\frac{\text{ø}250/9.8''}{\text{ø}220/8.6''}$ 		<b>2P0123</b> $\frac{\text{ø}250/9.8''}{\text{ø}220/8.6''}$ 
	<b>2P0221</b> $\frac{\text{ø}270/10.6''}{\text{ø}160/6.3''}$ 		<b>2P0222</b> $\frac{\text{ø}270/10.6''}{\text{ø}160/6.3''}$ 		<b>2P0223</b> $\frac{\text{ø}270/10.6''}{\text{ø}160/6.3''}$ 
	<b>2P0421</b> $\frac{220/8.6''}{\text{ø}190/7.5''}$ 		<b>2P0422</b> $\frac{220/8.6''}{\text{ø}190/7.5''}$ 		<b>2P0423</b> $\frac{220/8.6''}{\text{ø}190/7.5''}$ 
	<b>2P0311</b> $\frac{\text{ø}165/6.5''}{\text{ø}130/5.1''}$ 		<b>2P0312</b> $\frac{\text{ø}165/6.5''}{\text{ø}130/5.1''}$ 		<b>2P0313</b> $\frac{\text{ø}165/6.5''}{\text{ø}130/5.1''}$ 
	<b>2P0625</b> $\frac{\text{ø}250/9.8''}{\text{ø}220/8.6''}$ 		<b>2P0626</b> $\frac{\text{ø}250/9.8''}{\text{ø}220/8.6''}$ 		<b>2P0627</b> $\frac{\text{ø}250/9.8''}{\text{ø}220/8.6''}$ 
	<b>2P0720</b> $\frac{\text{ø}320/12.6''}{210/8.2''}$ 		<b>2P0763</b> $\frac{\text{ø}210/8.3''}{\text{ø}120/4.7''}$ 		

# Floor lamps

	<p><b>2P0131</b></p> <p>ø400/15.7" ø360/14.1" 300/11.8"</p>		<p><b>2P0132</b></p> <p>ø400/15.7" ø360/14.1" 300/11.8"</p>		<p><b>2P0133</b></p> <p>ø400/15.7" ø360/14.1" 300/11.8"</p>
	<p><b>2P0231</b></p> <p>ø400/15.7" ø240/9.4" 290/11.4"</p>		<p><b>2P0232</b></p> <p>ø400/15.7" ø240/9.4" 290/11.4"</p>		<p><b>2P0233</b></p> <p>ø400/15.7" ø240/9.4" 290/11.4"</p>
	<p><b>2P0431</b></p> <p>320/12.6" ø270/10.6" 300/11.8"</p>		<p><b>2P0432</b></p> <p>320/12.6" ø270/10.6" 300/11.8"</p>		<p><b>2P0433</b></p> <p>320/12.6" ø270/10.6" 300/11.8"</p>
	<p><b>2P0635</b></p> <p>ø400/15.7" ø360/14.1" 300/11.8"</p>		<p><b>2P0636</b></p> <p>ø400/15.7" ø360/14.1" 300/11.8"</p>		<p><b>2P0637</b></p> <p>ø400/15.7" ø360/14.1" 300/11.8"</p>
	<p><b>2P0730</b></p> <p>ø450/17.7" 310/12.2"</p>		<p><b>2P0730</b></p> <p>ø450/17.7" 310/12.2"</p>		<p><b>2P0730</b></p> <p>ø450/17.7" 310/12.2"</p>



# STRUCTURES

## ARTIS wall



68490 bronze

68491 chrome

## ARTIS wall reader



68492 bronze

68493 chrome

## ARTIS wall extensible

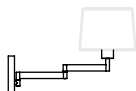

68494 bronze

68495 chrome

## CONGA/MAMBO/SAMBA wall



64306 matt white

64307 matt black

## CONGA/MAMBO/SAMBA wall reader



64308 matt white

64309 matt black

## CONGA/MAMBO/SAMBA suspended (turnbuckle)



64314 matt black

## CONGA/MAMBO/SAMBA suspended



64315 matt black

## CONGA/MAMBO/SAMBA table (small)



64316 matt white

64317 matt black

## CONGA/MAMBO/SAMBA table



64310 matt white

64311 matt black

## CONGA/MAMBO/SAMBA floor



64312 matt white

64313 matt black

## ETERNA wall



24005 chrome

## ETERNA wall reader/aplique con lector



24006 chrome/cromo (right)

24007 chrome/cromo (left)

## ETERNA table

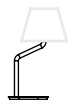

24008 chrome

## FRAME wall



20170 matt nickel

20171 old gold

## FRAME wall reader



20172 matt nickel

20173 old gold

## MONTREAL wall



24030 white

24031 chrome

## MONTREAL wall reader



24032 white

24033 chrome

## MONTREAL table

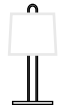

24034 white

24035 chrome

## MONTREAL floor

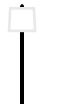

24036 white

24037 chrome

## REM wall



29680 matt nickel

29681 old gold

## REM wall reader



29682 matt nickel

29683 old gold

## REM table



29684 matt nickel

29685 old gold

## REM floor



29686 matt nickel

29687 old gold

## RON wall



64400 dark grey













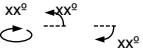

# GENERAL INFORMATION

EN	ES	FR	ITA
<p>The technical information detailed in our catalogue can be modified in order to improve the features or design of our products.</p> <p>Faro Barcelona keeps the right to cancel or modify any model without prior notice and without any cause for complaints.</p> <p>The conditions, technical characteristics and prices of the products that appear in this catalogue are the effective ones in the date of impression of the catalogue except for typographical error and are subject to possible changes.</p> <p>The catalogue prices are public prices.</p> <p>RATES DO NOT INCLUDE VAT.</p> <p>Returned goods shall only be accepted, after prior notice being given to LOREFAR, on the grounds of being defective and never on the basis of broken glass or missing parts. In such cases, please contact us so that we can send you the required parts as a matter of urgency.</p> <p>Exchanges or returns of goods in good condition will not be accepted. In the event of express acceptance by LOREFAR, a 20% charge shall be incurred, on receipt and checking, for depreciation and classification of the goods.</p>	<p>La información referente a nuestros productos puede ser modificada con el fin de mejorar las características técnicas o de diseño.</p> <p>Faro Barcelona se reserva el derecho de anular o modificar cualquier modelo sin previo aviso y sin que sea motivo de reclamaciones.</p> <p>Las condiciones, características y precios de los productos que aparecen en este catálogo son los vigentes en la fecha de impresión del catálogo salvo error tipográfico y están sujetos a posibles modificaciones, la versión digital siempre prevalece.</p> <p>Los precios mostrados son precios de venta al público (PVP).</p> <p>IVA NO INCLUIDO EN TARIFA</p> <p>Previa comunicación a Lorefar sólo se aceptará la mercancía devuelta por defectuosa, nunca por cristales rotos o falta de algún componente. En estos casos rogamos se pongan en contacto con nosotros para enviarles urgentemente las piezas requeridas.</p> <p>No se admitirán cambios ni devoluciones de mercancía en buen estado. En caso de aceptación explícita por parte de Lorefar, a su recepción y comprobación se emitirá un cargo del 20% en concepto de depreciación y clasificación de la mercancía.</p>	<p>L'information qui se réfère à nos produits peut être modifiée afin d'améliorer les caractéristiques technique ou de design.</p> <p>Faro Barcelona se réserve le droit d'annuler ou de modifier n'importe quel modèle sans préavis et sans que cela soit motif de réclamations.</p> <p>Les conditions, caractéristiques et prix des produits qui apparaissent dans ce catalogue sont celles en vigueur à la date d'impression du catalogue sauf erreur typographique et sont susceptible d'être modifiées ultérieurement.</p> <p>Les prix du catalogue son les prix de vente public .</p> <p>IVA NON COMPRISE DANS LE TARIF.</p> <p>Seule sera acceptée en retour la marchandise défectueuse, et ce après communication à LOREFAR. LOREFAR n'acceptera jamais de retour pour du verre brisé ou pour l'absence d'un composant quelconque. Dans ces derniers cas, nous vous prions de vous mettre en contact avec nous afin que nous vous fassions parvenir dans les plus brefs délais les pièces nécessaires. La marchandise en bon état ne sera ni reprise ni échangée. En cas d'acceptation explicite de sa part, LOREFAR retiendra 20% au titre de la dépréciation et de la classification du produit.</p>	<p>La informazione che si riferisce ai nostri articoli può essere soggetta a modifiche con il fine di migliorare le caratteristiche, tecniche o di design, dei nostri prodotti. Faro Barcelona si riserva il diritto di annullare o modificare qualsiasi modello senza previo avviso e senza che sia motivo di reclami.</p> <p>Le condizioni, caratteristiche e prezzi dei prodotti che compaiono in questo catalogo sono quelli vigenti alla data della stampa del catalogo ad eccezione di errori tipografici e sono soggetti a possibili modificazioni.</p> <p>I prezzi indicati sono prezzi di vendita al pubblico.</p> <p>IVA NON INCLUSA IN LISTINO.</p> <p>LOREFAR accetta previa comunicazione, solo la merce restituita perché difettosa; in nessun caso accetterà la merce restituita per presenza di vetri rotti o per mancanza di qualche componente. In questi casi vi preghiamo di contattarci per potervi mandare al più presto i pezzi richiesti.</p> <p>Non si effettuano cambi né si ammettono restituzioni di merci in buono stato. In caso di accettazione esplicita da parte di LOREFAR, al momento del ricevimento e della verifica della merce si emetterà un addebito del 20% a titolo di deprezzamento e classificazione.</p>
PT	GER	NL	GRK
<p>A informação referente aos nossos produtos pode ser modificada com o fim de melhorar as características técnicas ou de desenho.</p> <p>A Faro Barcelona reserva-se o direito de anular ou modificar qualquer modelo sem aviso prévio e sem que seja motivo de reclamações.</p> <p>As condições, características e preços dos produtos que aparecem neste catálogo são os vigentes na data de impressão do catálogo salvo erro tipográfico e estão sujeitos a possíveis modificações. Os preços mostrados são preços de venda ao público (PVP).</p> <p>IVA NÃO INCLUIDO NA LISTA DE PREÇOS</p> <p>Mediante comunicação prévia à Lorefar, apenas se aceitará a mercadoria devolvida por defeito, nunca por vidros partidos ou falta de algum componente. Nestes casos pedimos que entrem em contacto conosco para lhes enviarmos urgentemente as peças requeridas.</p> <p>Não serão admitidas alterações nem devoluções de mercadoria em bom estado. Em caso de aceitação explícita por parte da Lorefar, na sua recepção e comprovação emitir-se-á um débito de 20% a título de depreciação e classificação da mercadoria.</p>	<p>Die Information über unsere Produkte kann im Zusammenhang mit den Verbesserungen ihrer technischen Eigenschaften und ihres Designs jederzeit geändert werden.</p> <p>Faro Barcelona behält sich das Recht vor, seine Modelle jederzeit und ohne vorherige Ankündigung vom Markt zu nehmen, ohne dass sich daraus ein Anrecht auf Beschwerden ableiten könnte.</p> <p>Die Bedingungen, Eigenschaften und Preise der Produkte in diesem Katalog gelten zum Datum der Drucklegung des Katalogs vorbehaltlich Druckfehler und können jederzeit geändert werden. Diese Preise gelten für den Direktverkauf an den Kunden.</p> <p>DIE MEHRWERTSTEUER IST NICHT IN DEN PREISEN EINGESCHLOSSEN</p> <p>Nach vorheriger Kommunikation kann Lorefar die Rücklieferung von schadhafter Ware akzeptieren, jedoch niemals wegen beschädigten Glasteilen oder fehlenden Komponenten. In letzteren Fällen setzen Sie sich bitte zwecks schneller Zusage der notwendigen Teile in Verbindung.</p> <p>Wir tauschen keine Waren in gutem Zustand um oder nehmen sie zurück. Bei ausdrücklicher Annahme durch Lorefar nach Erhalt und Überprüfung stellen wir Ihnen 20% des Preises für Wertverminderung und Handhabung der Ware in Rechnung.</p>	<p>De informatie over onze producten kan gewijzigd worden met als doel de technische eigenschappen of het design te verbeteren.</p> <p>Faro Barcelona behoudt zich het recht voor onaanvaardig modellen te schrappen of te wijzigen en zonder dat dit aanleiding tot een klacht vormt.</p> <p>De voorwaarden, eigenschappen en prijzen van de producten in deze catalogus zijn geldig op het moment van druk van de catalogus tenzij sprake is van een drukfout. Zij zijn onderhevig aan mogelijke wijzigingen. De getoonde prijzen betreffen verkoopprijzen.</p> <p>Btw NIET BIJ DE PRIJS INBEGREPEN</p> <p>Lorefar aanvaardt uitsluitend defecte teruggezonden goederen nadat zij hierover van tevoren op de hoogte is gesteld. Dit geldt niet voor gebroken glas of het ontbreken van onderdelen. In deze gevallen wordt u verzocht met ons contact op te nemen zodat wij u zo snel mogelijk de gewenste onderdelen kunnen toezenden.</p> <p>Ruilen of terugsturen van goederen in correcte staat is niet toegestaan. In geval van uitdrukkelijke aanvaarding door Lorefar wordt bij ontvangst en controle een heffing van 20% voor waardevermindering en classificatie van de goederen toegepast.</p>	<p>Οι πληροφορίες σχετικά με τα προϊόντα μας ενδέχεται να τροποποιηθούν με στόχο τη βελτίωση των τεχνικών χαρακτηριστικών ή του σχεδίου. Η Faro Barcelona διατηρεί το δικαίωμα ακύρωσης ή τροποποίησης οποιοδήποτε μοντέλου χωρίς προηγούμενη προειδοποίηση και χωρίς αυτό να αποτελεί αιτία απαίτησης επιστροφής χρημάτων. Οι όροι, τα χαρακτηριστικά και οι τιμές των προϊόντων που παρουσιάζονται σε αυτόν τον κατάλογο είναι αυτά που ισχύουν κατά την ημερομηνία της εκτύπωσης του καταλόγου, εκτός τυπογραφικών λαθών, και υπόκεινται σε αλλαγές. Ο ΦΠΑ ΔΕΝ ΣΥΜΠΕΡΙΛΑΜΒΑΝΕΤΑΙ ΣΤΗΝ ΤΙΜΗ</p> <p>Μετά από συνεννόηση με τη Lorefar, γίνονται αποδεκτές επιστροφές μόνο αν πρόκειται για ελαττωματικά εμπορεύματα και όχι για θραύση κρυστάλλων ή απουσία κάποιου στοιχείου. Στις περιπτώσεις αυτές, παρακαλούμε να έρθετε σε επαφή μαζί μας για να σας στείλουμε επείγοντως τα απαιτούμενα μέρη.</p>
RUS	CZ	BL	PL
<p>Информация относящаяся к нашей продукции может быть модифицирована с целью улучшить технические или внешние характеристики.</p> <p>Faro Barcelona сохраняет за собой право аннулировать или модифицировать любую модель без предупреждения и без того что это послужит причиной для жалоб.</p> <p>Условия, характеристики и цены на изделия, указанные в данном каталоге, действительны на дату его выпуска, за исключением опечаток в каталоге, и могут быть изменены. В каталоге указаны розничные цены.</p> <p>БЕЗ УЧЕТА НДС</p> <p>В соответствии с правилами, компания Lorefar принимает возврат изделий только при наличии дефектов, но ни в коем случае не при разбитии стекла или отсутствии какой-либо детали. В таком случае, пожалуйста, свяжитесь с нами, чтобы мы отправили вам необходимые детали. Товар в рабочем состоянии не подлежит обмену или возврату. В случае подтверждения компанией Lorefar наличия дефектов, после возврата и проверки, начисляется 20% стоимости с учетом амортизации и классификации товаров.</p>	<p>Technické informace uvedené v katalogu mohou být modifikovány za účelem zdokonalování vlastností svítidel nebo jejich designu.</p> <p>Producent Faro Barcelona si vyhrazuje právo konstrukčních změn nabízených modelů bez předcházejícího oznámení a tato skutečnost nemůže být předmětem jakékoliv stížnosti či reklamace.</p> <p>Podmínky, technické specifikace a ceny produktů uvedené v katalogu jsou platné ke dni vydání katalogu. Producent si vyhrazuje právo konstrukčních změn nabízených modelů, pokud tyto nepovedou k zásadním změnám charakteru výrobků. Informace z tohoto katalogu postrádají platnosti v den vydání katalogu nového.</p> <p>VŠECHNY CENY JSOU UVEDENY BEZ DPH., Zboží může být vráceno pouze po předchozím souhlasu od společnosti PAXI, na základě poruchy nebo vady ovšem nikdy na základě poškozeného skla nebo chybějícího dílu. V takových případech nás, prosím, kontaktujte, abychom Vám mohli požadované části svítidel urgentně zaslat. Výměny nebo vrácení zboží v dobrém technickém stavu je nepřijatelné.</p>	<p>Техническая информация, представленная в нашем каталоге, может быть изменена с целью улучшения технических или внешних характеристик продукции.</p> <p>Фаро Барселона си запазва правото да отменя или променя всеки модел без предварително осведомяване и без това да се счита причина за оплаквания.</p> <p>Условията, техническите характеристики и цените на продуктите показани в този каталог са ефективни към датата на отпечатването на каталога, с изключение на грешки при отпечатване и са обект на възможни промени.</p> <p>Цените в каталога са публичните цени.</p> <p>ЦЕНИТЕ НЕ ВКЛЮЧВАТ ДДС.</p> <p>Връщане на закупена стока ще да бъдат приети единствено след писмено осведомяване на LOREFAR на основание дефекти и в никакъв случай на основание чулено стъкло или липсващи части. В такива случаи моля свържете се с нас, за да ви изпратим липсващите части по спешност.</p> <p>Размяна или връщане на стока в добро състояние няма да бъде извършвана. В случай на спешно приемане от LOREFAR 20 % такса ще бъде наложена за приемане и проверка, за обезценяване и класификация на продуктите.</p>	<p>Informacje techniczne wyszczególnione w naszym katalogu mogą być modyfikowane w celu poprawienia właściwości lub wyznaczenia produktów.</p> <p>Faro Barcelona ma prawo do anulowania i modyfikowania każdego z modeli bez uprzedniego informowania i nie przyjmując skarg z tego tytułu.</p> <p>Warunki, opis techniczny oraz ceny artykułów, które pojawiają się w katalogu są aktualne do czasu przedruku katalogu za wyjątkiem pomyłek w druku, które podlegają ewentualnej zmianie. Ceny w katalogu są cenami publicznymi.</p> <p>CENY NIE ZAWIERAJĄ STAWKI VAT.</p> <p>Ewentualne zwroty mogą być zaakceptowane po uprzedniej zgodzie przez Lorefar na podstawie stwierdzenia, że są wadliwe, nigdy nie przyjmowane zwroty artykułów, z powodu stłuczenia szkła czy brakujących części, w tym przypadku prosimy o kontakt w celu wysłania potrzebnych części w trybie natychmiastowym.</p> <p>Wymiany lub zwroty artykułów w dobrym stanie nie będą zaakceptowane. W przypadku wyraźnej akceptacji przez Lorefar, 20% opłaty może być poniesione na otrzymanie i sprawdzenie, w celu sklasyfikowania uszkodzenia artykułu.</p>

# MATERIALS

EN	ES	FR	ITA	DEU
<b>ABS</b>	ABS	ABS	ABS	ABS
<b>Acrylic</b>	Acrílico	Acrylique	Acrilico	Acryl
<b>Aluminium</b>	Aluminio	Aluminium	Alluminio	Aluminium
<b>Beige Ribbon Shade</b>	Tela encintada	Tissu adhésif	Tessuto registrato	Beigefarbener Bandschirm
<b>Bubble Glass</b>	Cristal Burbuja	Verre bullé	Vetro bolla	Blasenförmiges Glas
<b>Brass</b>	Latón	Laiton	Ottone	Messing
<b>Die Cast Aluminium</b>	Aluminio Inyectado	Fonte d'aluminium	Ghisa alluminio	Aluminium-Druckguss
<b>Fiber Glass</b>	Fibra de Vidrio	Fibre De Verre	Fibra Di Vetro	Glasfaser
<b>Glass</b>	Cristal	Verre	Vetro	Glas
<b>Leather</b>	Piel	Peau	Pelle	Leder
<b>Linen</b>	Lino	Lin	Biancheria	Leinen
<b>Marble</b>	Mármol	Marbre	Marmo	Marmor
<b>Opal Acrylic</b>	Acrílico Opal	Acrylique opale	Acrilico opale	Opal-Acryl
<b>Opal Glass</b>	Cristal Opal	Verre opale	Vetro opalino	Opal Glas
<b>Opal PMMA</b>	PMMA Opal	PMMA opale	PMMA opale	Opal PMMA
<b>Opal Polycarbonate</b>	Policarbonato Opal	Polycarbonate opale	Policar-bonato opale	Opal Polycarbonat
<b>Opal PVC</b>	PVC Opal	PVC opale	PVC opale	Opal PVC
<b>Papyrus</b>	Papiro	Papyrus	Papiro	Papyrus
<b>Parchment</b>	Pergamino	Parchemin	Pergamena	Pergament
<b>PEMD</b>	PEMD	PEMD	PEMD	PEMD
<b>PET Polyethylene Terephthalate</b>	PET Polietileno tereftalato	PET Polyéthylène téréphtalate	PET polietilene tereftalato	PET Polyethylenterephthalat
<b>Plaster</b>	Yeso	Gypse	Gesso	Gips
<b>PMMA</b>	PMMA	PMMA	PMMA	PMMA
<b>Polycarbonate</b>	Policarbonato	Polycarbonate	Policarbonato	Polycarbonat
<b>Polyethylene</b>	Polietileno	Polyéthylène	Polietilene	Polyethylen
<b>Polymer</b>	Polímero	Polymères	Polimero	Polymer
<b>Polypropylene</b>	Polipropileno	Polyéthylène	Polietilene	Polypropylen
<b>PVC</b>	PVC	PVC	PVC	PVC
<b>Rattan</b>	Ratán	Rotin	Malacca	Rattan
<b>Resine</b>	Resina	Résine	Resina	Kunstharz
<b>Rustic Glass</b>	Cristal Rústico	Verre rustique	Vetro rustico	Rustikales Glas
<b>Silicone</b>	Silicona	Silicone	Silicone	Silikon
<b>Stainless Steel</b>	Acero Inoxidable	Acier inoxydable	Acciaio inossi.	Rostfreier Stahl
<b>Steel</b>	Acero	Acier	Acciaio	Stahl
<b>Teflon</b>	Teflón	Teflon	Teflon	Teflon
<b>Textile</b>	Téxtil	Textile	Tessile	Textil
<b>Translucent Glass</b>	Cristal Translúcido	Verre translucide	Vetro traslucido	Lichtdurchlässig Glas
<b>Translucent Polycarbonate</b>	Policarbonato Translúcido	Polycarbonate translucide	Policar-bonato transl.	Transluzentes Polycarbonat
<b>Transparent Glass</b>	Cristal Transparente	Verre transparent	Vetro trasparente	Durchsichtiges Glas
<b>Transparent PMMA</b>	PMMA Transparente	PMMA transparent	PMMA trasparente	Durchsichtiges PMMA
<b>Wood</b>	Madera	Bois	Legno	Holz
<b>Zinc</b>	Zinc	Zinc	Zinco	Zink

# SYMBOLOLOGY

	EN	ES	FR	ITA	DEU
	Ingress Protection Marking against dust (X) and water (Y)	Grado de protección ante el polvo (X) y líquidos (Y)	Indice de protection contre la poussière (X) et l'eau (Y)	Protezione dall'ingresso Marcatura contro polvere (X) e acqua (Y)	Schutz gegen Eindringen von Staub (X) und Wasser (Y)
<b>IP68 CONNECTOR</b>					
IKXX	Shock resistance	Resistencia a los golpes	Résistance au choc	Resistenza agli urti	Stoßfestigkeit
	Switch	Interruptor	Interrupteur	Interruttore	Schalter
	Double Switch	Doble Interruptor	Double Interrupteur	Doppio Interruttore	Doppelschalter
	Adjustable	Orientable	Orientable	Regolabile	Ausrichtbar
	Dimmable	Dimable	Réglable	Regolabile	Dimmbar
	Color temperature adjustable	Temperatura de color ajustable	Température de couleur réglable	Temperatura di colore regolabile	Farbtemperatur einstellbar
<b>SEA SIDE SUITABLE</b>	Suitable for humid environments	Aptas para entornos húmedos	Adapté aux environnements humides	Adatto per ambienti umidi	Geeignet für nasse Umgebungen
	Driver included	Equipo incluido	Conducteur inclus	Driver incluso	Inklusive Treiber
	Driver not included	Equipo no incluido	Conducteur non inclus	Driver non incluso	Treiber nicht enthalten
	Recessed box included	Caja empotrar incluida	Boîte d'encastrement incluse	Scatola da incasso inclusa	Inklusive Unterputzdose
	Recessed box not included	Caja empotrar no incluida	Boîte d'encastrement non incluse	Scatola da incasso non inclusa	Unterputzdose nicht enthalten
	Plug	Enchufe	Fiche	Plug	Stecker
	Submersible	Sumergible	Submersible	Sommergibile	Untertauchbar
	Solar	Solar	Solaire	Solare	Solar
	Passive Infrared sensor	Detector de movimiento pasivo	Capteur infrarouge passif	Sensore passivo a infrarossi	Passiver Bewegungsmelder
	Resistance in kg	Resistencia en kg	Résistance en kg	Resistenza in kg	Widerstand in kg



Ref	Pag.	Ref	Pag.	Ref	Pag.	Ref	Pag.
01004	450	20332	364	28287	178	29864	246
01006	450	20400	50	28300	182	29865	246
01016	62	20401	50	28301	182	29866	158
01017	62	20402	50	28302	182	29867	158
01041	478	20403	52	28370	132	29868	158
01046	168	20404	52	28371	132	29869	158
20026	164	20405	52	28373	218	29871	564
20029	164	20406	54	28374	218	29872	564
20030	164	20407	54	28375	210	29873	520
20046	206	20408	54	28376	210	29874	520
20047	206	23065	90	28378	106	29875	520
20048	206	23066	90	28379	106	29876	520
20049	474	24015	442	28380	108	29877	294
20050	206	24016	442	28382	108	29878	294
20051	206	28209	210	28383	108	29881	130
20052	342	28210	210	28385	108	29882	130
20053	342	28211	106	28387	102	29883	130
20054	150	28212	106	28388	102	29884	130
20055	150	28251	72	28398	248	29894	266
20056	86	28252	72	28399	248	29895	266
20057	86	28253	72	28401	112	29896	564
20069	96	28254	72	28413	412	29897	520
20075	94	28255	72	28414	412	29898	130
20076	94	28256	72	28415	412	29899	130
20077	336	28257	324	28430	98	29940	402
20079	196	28258	324	28431	98	29944	246
20116	202	28259	324	29306	474	29946	402
20117	202	28260	178	29307	154	29948	162
20118	202	28261	178	29309	246	29950	410
20119	202	28262	178	29310	474	29951	410
20120	202	28263	178	29311	154	29955	172
20121	202	28264	178	29312	154	29958	172
20122	202	28265	178	29313	246	29974	404
20123	202	28266	180	29326	408	29975	404
20124	202	28267	180	29328	408	29976	404
20125	202	28268	180	29329	408	29979	152
20126	202	28269	72	29330	408	29980	406
20127	202	28270	72	29331	408	29981	406
20128	202	28271	72	29332	160	29982	406
20129	202	28272	72	29333	160	29983	406
20130	202	28274	324	29335	160	29984	152
20131	202	28275	324	29336	160	29985	152
20160	194	28277	178	29468	248	29986	244
20161	194	28278	178	29690	362	29996	398
20167	366	28279	178	29695	362	29997	156
20168	366	28280	178	29698	124	29998	156
20169	194	28281	180	29764	174	34000	995
20208	66	28282	180	29844	376	34001	995
20209	66	28283	178	29846	128	34002	995
20210	66	28284	178	29847	128	34004	1003
20330	364	28285	178	29848	204	34009	995
20331	364	28286	178	29849	204	34010	995

Ref	Pag.	Ref	Pag.	Ref	Pag.	Ref	Pag.
34011	995	43398	538	43754	266	62120	444
34012	995	43399	542	43755	266	62121	444
34013	995	43400	542	43756	266	62122	446
34014	995	43401	540	43757	566	62123	446
40070	470	43402	540	43758	306	62124	446
40076	498	43403	540	43759	480	62125	446
40085	498	43404	542	43760	480	62126	444
40086	498	43405	542	43761	550	62128	444
40087	498	43406	538	43762	510	62129	444
40088	498	43407	538	43763	510	62130	448
40090	362	43408	538	43764	306	62131	448
40091	362	43409	542	43765	480	62132	290
40092	362	43410	542	43766	480	62133	290
40093	362	43411	540	43767	418	62134	290
40095	360	43412	540	43768	418	62135	290
40096	360	43413	540	43900	548	62139	226
40097	360	43500	516	51129	430	62150	464
40098	360	43501	516	51133	430	62151	464
40099	360	43502	516	51134	430	62152	464
40110	532	43520	518	51135	430	62153	464
40111	532	43521	518	51908	120	62154	464
40112	534	43522	518	51909	120	62155	464
40113	534	43525	518	51910	120	62156	102
40114	532	43527	518	51916	120	62157	102
40115	532	43528	518	51917	120	62161	422
40116	534	43531	294	53415	114	62162	422
40117	534	43534	294	53416	114	62163	422
40118	532	43600	546	57300	350	62164	422
40119	532	43601	546	57301	350	62168	102
40120	534	43720	566	57302	350	62169	102
40121	534	43721	566	57312	100	62170	464
40122	536	43722	510	57313	100	62171	464
40123	536	43723	510	57314	100	62172	464
40124	536	43728	510	57315	100	62300	466
40125	536	43729	510	57316	100	62301	466
40126	536	43730	510	57317	100	62302	466
40127	536	43731	510	57318	350	62303	466
40135	452	43732	510	57319	350	62355	448
40136	452	43740	512	57320	350	62360	448
40550	520	43741	512	57402	472	62361	448
40551	520	43742	512	57403	472	62703	436
40660	514	43743	512	60004	260	62705	414
40661	514	43744	512	61117	200	62706	414
40662	514	43745	512	62104	444	62800	262
40663	514	43746	306	62105	454	62801	262
40664	514	43747	306	62108	454	62802	262
40665	514	43748	480	62111	444	62803	262
40666	514	43749	480	62114	444	62804	262
40667	514	43750	480	62115	422	62805	262
42919	550	43751	480	62116	444	62806	256
43396	538	43752	550	62117	444	62807	472
43397	538	43753	550	62118	444	62809	468

Ref	Pag.	Ref	Pag.	Ref	Pag.	Ref	Pag.
62810	468	63506	500	66406	460	70151	788
62965	316	63507	504	66407	460	70226	786
62966	316	63508	504	66408	460	70227	786
62968	318	63509	504	66409	460	70245	778
62969	318	63510	498	66410	460	70246	778
62980	316	63512	504	66411	462	70260	750
62981	316	63513	504	66412	462	70290	834
62983	318	63514	504	66413	463	70291	834
62986	496	64026	454	66414	463	70304	944
62987	496	64027	362	66415	463	70306	946
62988	414	64028	362	66416	463	70307	946
63124	308	64030	452	68145	260	70308	945
63125	308	64128	256	68146	260	70309	945
63167	466	64133	258	68153	264	70310	946
63173	486	64137	252	68283	272	70443	964
63174	486	64168	432	68284	272	70444	964
63175	486	64169	432	68298	310	70446	968
63176	488	64183	292	68317	310	70449	962
63177	488	64202	564	68334	120	70453	956
63268	300	64203	564	68423	112	70455	966
63269	300	64231	280	68461	248	70498	606
63270	296	64232	280	68462	174	70501	938
63271	296	64255	192	68463	174	70508	938
63272	296	64256	192	68467	420	70546	936
63273	296	64257	192	68468	420	70547	936
63274	298	64258	192	68488	148	70564	936
63275	298	64259	192	68489	148	70573	880
63276	298	64261	220	68496	424	70575	820
63277	298	64270	354	68497	424	70576	672
63278	484	64271	354	68498	424	70586	958
63281	530	64272	354	68499	424	70587	958
63282	530	64273	354	68500	170	70588	958
63283	530	64274	354	68501	170	70589	958
63284	484	64302	400	68503	170	70591	960
63285	490	64303	400	68504	416	70655	938
63286	526	64304	400	68507	416	70656	938
63290	526	64305	400	68508	424	70660	954
63311	492	64318	428	68509	424	70661	954
63312	492	64319	428	68561	250	70662	954
63316	506	64321	266	68562	250	70689	876
63317	506	64322	414	68563	250	70690	828
63318	506	64323	414	68564	250	70696	878
63319	506	64500	224	68569	264	70697	878
63399	312	64501	224	68602	280	70714	886
63420	334	65071	258	68610	284	70715	876
63421	334	65081	254	68611	284	70720	882
63422	334	65082	254	70035	756	70722	828
63490	528	65134	252	70036	756	70726	950
63491	528	65137	306	70037	758	70728	950
63503	502	66403	462	70038	758	70729	950
63504	500	66404	462	70039	756	70730	950
63505	500	66405	460	70146	972	70731	950

Ref	Pag.	Ref	Pag.	Ref	Pag.	Ref	Pag.
70732	950	70993	678	71352	690	72280	886
70733	952	70996	866	71353	922	72281	886
70734	952	70997	868	71363	922	72310	676
70735	952	70998	868	71366	922	73150	792
70736	952	70999	866	71367	922	74139	844
70753	688	71106	816	71372	822	74141	644
70754	688	71110	862	71374	822	74142	644
70755	688	71116	730	71383	746	74261	864
70756	688	71117	730	71389	746	74400	926
70761	690	71118	730	71390	746	74401	898
70767	658	71128	862	71424	860	74407	930
70768	658	71129	862	71480	976	74408	930
70771	674	71138	816	71481	976	74411	692
70773	870	71139	816	71482	976	74419	924
70774	694	71140	864	71490	976	74422	626
70775	600	71194	836	71491	976	74423	626
70776	600	71195	836	71516	894	74424	626
70777	600	71196	836	71517	894	74441	652
70784	598	71198	686	71519	894	74442	652
70785	694	71199	686	71528	780	74454	598
70786	600	71209	718	71546	752	74465	60
70790	592	71212	890	71547	752	74997	660
70799	820	71213	682	71548	752	74998	852
70802	916	71214	682	71549	752	75000	852
70806	822	71215	890	71565	606	75001	660
70811	914	71222	892	71606	860	75003	660
70812	914	71223	892	71613	790	75500	928
70813	914	71224	642	71740	824	75501	928
70821	822	71225	642	71741	824	75502	928
70823	874	71242	624	71742	824	75503	928
70824	932	71243	624	71743	850	75519	684
70825	932	71253	628	71744	850	75520	684
70826	932	71254	628	71745	850	75521	676
70827	876	71256	630	71746	654	75531	650
70828	914	71257	630	71747	654	75533	842
70829	884	71262	622	71748	654	75558	634
70832	920	71263	622	71749	654	75559	634
70833	970	71274	876	71750	654	75561	768
70834	970	71276	902	71751	654	75562	768
70840	688	71277	900	71903	904	75605	664
70841	688	71279	846	71904	904	75606	664
70842	688	71285	848	71905	904	75750	840
70843	688	71286	648	71912	596	75751	840
70887	880	71287	648	71913	596	75753	810
70888	912	71299	656	71914	596	75754	810
70899	912	71300	656	72002	888	75755	810
70900	970	71301	656	72010	888	750000	702
70901	970	71303	870	72011	888	750001	702
70912	750	71305	872	72092	974	750002	702
70913	790	71306	872	72093	974	750010	702
70914	604	71308	900	72094	974	750011	702
70992	868	71309	900	72095	974	750012	702



Ref	Pag.	Ref	Pag.	Ref	Pag.	Ref	Pag.
750020	702	751211	714	01040-110	478	20300-92	382
750021	702	751212	714	20031-122	328	20301-93	382
750022	702	751220	714	20031-123	328	20301-94	382
750100	704	751221	714	20031-80	370	20304-82	144
750101	704	751222	714	20031-81	370	20305-83	144
750102	704	751300	716	20031-88	398	20305-84	144
750110	704	751301	716	20032-122	328	20306-85	144
750111	704	751302	716	20032-123	328	20307-86	144
750112	704	751310	716	20032-80	370	20307-87	144
750120	704	751311	716	20032-81	370	20308-89	242
750121	704	751312	716	20032-88	398	20309-90	242
750122	704	751320	716	20033-122	76	20309-91	242
750200	706	751321	716	20033-123	76	20335-116	332
750201	706	751322	716	20033-80	122	20335-117	332
750202	706	2100301	548	20033-81	122	20336-119	80
750210	706	2100501	556	20034-122	76	20336-120	80
750211	706	2100502	556	20034-123	76	20337-116	80
750212	706	2100503	556	20034-80	122	20337-117	80
750220	706	2100601	560	20034-81	122	20338-116	186
750221	706	2100602	560	20034-88	156	20338-117	186
750222	706	2100603	560	20040-122	328	20338-119	186
750300	708	2100701	558	20040-123	328	20338-120	186
750301	708	2100702	558	20046-3L	276	20339-116	184
750302	708	2100801	548	20046-5L	276	20339-117	184
750310	708	2100901	550	20046-7L	276	20339-119	184
750311	708	2101001	552	20050-3L	276	20339-120	184
750312	708	2101002	552	20050-5L	276	20340-116-3L	278
750320	708	2101101	552	20050-7L	276	20340-116-5L	278
750321	708	2101102	552	20160-3L	278	20340-116-7L	278
750322	708	2101301	554	20160-5L	278	20340-117-3L	278
751000	710	2101302	554	20160-7L	278	20340-117-5L	278
751001	710	2101401	560	20161-3L	278	20340-117-7L	278
751002	710	2101402	560	20161-5L	278	20340-119-3L	278
751010	710	2101501	554	20161-7L	278	20340-119-5L	278
751011	710	2101601	554	20164-95	166	20340-119-7L	278
751012	710	2111001	544	20164-96	166	20340-120-3L	278
751020	710	2111002	544	20165-95	366	20340-120-5L	278
751021	710	2121001	544	20165-96	366	20340-120-7L	278
751022	710	2121002	544	20166-95	194	20342-116	332
751100	712	2200501	556	20166-96	194	20342-117	332
751101	712	2200502	556	20170-01	396	20343-116-5L	188
751102	712	2200503	556	20170-02	396	20343-117-5L	188
751110	712	2300101	558	20170-03	396	20343-119-5L	188
751111	712	2400101	560	20171-01	396	20343-120-5L	188
751112	712	2400102	560	20171-02	396	23001-57	90
751120	712	01001-110	368	20171-03	396	23001-58	90
751121	712	01007A	104	20172-01	396	23002-57	92
751122	712	01009A	372	20172-02	396	23002-58	92
751200	714	01014A	374	20172-03	396	23003-59	92
751201	714	01025A	104	20173-01	396	23003-60	92
751202	714	01026A	374	20173-02	396	23004-57	340
751210	714	01027A	372	20173-03	396	23004-58	340

Ref	Pag.	Ref	Pag.	Ref	Pag.	Ref	Pag.
24005-10	392	29565-110	378	32038UL-18	1091	33698-110	1115
24005-11	392	29566-110	378	32038WP-18	1091	33699-110	1115
24005-12	392	29568-110	126	32039UL-18	1091	33700-110	1055
24006-10-110	392	29569-110	126	32039WP-18	1091	33701-110	1055
24006-11-110	392	29680-19	394	32040UL-19	1091	34276WP-11L-110	1015
24006-12-110	392	29680-20	394	32040WP-19	1091	34277WP-11L-110	1105
24007-10-110	392	29680-21	394	32041UL-19	1091	34278WP-11L-110	1105
24007-11-110	392	29681-19	394	32041WP-19	1091	34279WP-11L-110	1015
24007-12-110	392	29681-20	394	32042UL-19	1091	34281WP-11L-110	1129
24008-13	110	29681-21	394	32042WP-19	1091	34282WP-11L-110	1015
24008-14	110	29683-19	394	32043UL-19	1091	34283WP-11L-110	1105
24008-15	110	29683-20	394	32043WP-19	1091	34284WP-11L-110	1129
24020-31	134	29683-21	394	32100UL-19	1083	34301WP-11L-110	1069
24020-32	134	29685-04	146	32100WP-19	1083	40994-110	426
24023-33	134	29685-05	146	33179-110	1145	40996-110	426
24023-34	134	29685-06	146	33183-110	1145	41019-110	426
24030-01	382	29687-07	146	33186-110	1145	41020-110	426
24030-02	382	29687-08	146	33356-110	1047	41023-110	438
24031-01	382	29687-09	146	33357-110	1047	41025N	434
24031-02	382	29691-110	208	33381UL-18	1079	42921-110	544
24031-03	382	29692D-110	124	33381WP-18	1079	43724-110	566
24034-04	142	29693D	124	33382UL-18	1075	43725-110	566
24034-05	142	29696-110	208	33382WP-18	1075	43726-110	510
24036-07	142	29697-110	124	33389-110	1039	43727-110	510
24036-08	142	32000UL-18	1079	33393UL-18	1091	52064-110	116
24037-07	142	32000WP-18	1079	33393WP-18	1091	52065-110	116
24037-08	142	32001UL-18	1079	33394DWP-18	1087	57211-01	166
24037-09	142	32001WP-18	1079	33394WP-18	1083	57211-03	166
28209-1L	212	32002UL-19	1079	33395DWP-19	1087	61081-110	494
28209-2L	214	32002WP-19	1079	33395UL-19	1083	61082-110	494
28209-3L	214	32003UL-19	1079	33395WP-19	1083	61084-110	494
28209-4L	216	32003WP-19	1079	33397-110	1052	61085-110	494
28209-5L	218	32004UL-19	1079	33398DWP-19	1087	61087-110	494
28210-1L	212	32004WP-19	1079	33398UL-19	1083	61088-110	494
28210-2L	214	32005UL-18	1079	33398WP-19	1083	61101-110	200
28210-3L	214	32005WP-18	1079	33399DWP-19	1087	61103-110	200
28210-4L	216	32006UL-19	1079	33399UL-19	1083	61104-110	200
28210-5L	218	32006WP-19	1079	33399WP-19	1083	61105-110	200
28375-1L	212	32020UL-18	1075	33415-110	1125	62140-110	290
28375-2L	212	32020WP-18	1075	33416-110	1125	62141-110	290
28375-3L	214	32025UL-18	1075	33417WP-19	1083	62142-110	290
28375-4L	216	32025WP-18	1075	33418WP-19	1083	62143-110	290
28375-5L	218	32026UL-19	1075	33423WP-19	1143	62144-110	290
28376-1L	212	32026WP-19	1075	33424WP-19	1143	62145-110	290
28376-2L	212	32027WP-19	1075	33427WP-19	1143	62146-110	290
28376-3L	214	32028UL-19	1075	33428WP-19	1143	62147-110	290
28376-4L	216	32028WP-19	1075	33429WP-19	1143	62173-50	346
28376-5L	218	32029UL-18	1075	33460-110	1037	62173-51	347
29395-110	378	32029WP-18	1075	33466-110	1003	62173-69	359
29396-110	378	32030UL-19	1075	33695-110	1115	62173-78	358
29398-110	126	32030WP-19	1075	33696-110	1115	62174-50	346
29399-110	126	32033WP-18	1095	33697-110	1115	62174-51	347

Ref	Pag.	Ref	Pag.	Ref	Pag.	Ref	Pag.
62174-69	359	64214A	280	64277-110	286	64314-45	238
62174-78	358	64215A	280	64278-110	286	64314-45-3L	276
62704-110	440	64224-110	268	64279-110	286	64314-45-5L	276
62707-110	428	64250-110	292	64280-110	286	64314-45-7L	276
62708-110	428	64251-110	292	64281-110	288	64314-46	238
62710-110	428	64255-111-3L	279	64282-110	288	64314-46-3L	276
62711-110	428	64255-111-5L	279	64306-01	384	64314-46-5L	276
62802-3L	277	64255-111-7L	279	64306-02	384	64314-46-7L	276
62802-5L	277	64255-112-3L	279	64306-35	380	64314-47	236
62802-7L	277	64255-112-5L	279	64306-36	380	64314-47-3L	275
62803-3L	277	64255-112-7L	279	64306-37	380	64314-47-5L	275
62803-5L	277	64255-113-3L	279	64307-03	384	64314-47-7L	275
62803-7L	277	64255-113-5L	279	64307-35	380	64314-48	236
62804-3L	278	64255-113-7L	279	64307-36	380	64314-48-3L	275
62804-5L	278	64255-114-3L	279	64307-37	380	64314-48-5L	275
62804-7L	278	64255-114-5L	279	64307-47	388	64314-48-7L	275
62805-3L	278	64255-114-7L	279	64307-71	386	64314-49	236
62805-5L	278	64255-115-3L	279	64308-01	384	64314-49-3L	275
62805-7L	278	64255-115-5L	279	64308-02	384	64314-49-5L	275
62819-110	482	64255-115-7L	279	64308-35	380	64314-49-7L	275
62820-110	482	64255-124	192	64308-36	380	64314-54	240
62821-110	482	64255-124-3L	279	64308-37	380	64314-54-3L	276
62822-110	482	64255-124-5L	279	64309-03	384	64314-54-5L	276
63225-110	492	64255-124-7L	279	64309-35	380	64314-54-7L	276
63279-110	490	64255-125	192	64309-36	380	64314-55	240
63404-110	314	64255-125-3L	279	64309-37	380	64314-55-3L	276
63481-110	524	64255-125-5L	279	64309-47	388	64314-55-5L	276
64128-3L	277	64255-125-7L	279	64309-71	386	64314-55-7L	276
64128-5L	277	64255-126	192	64310-04	140	64314-56	240
64128-7L	277	64255-126-3L	279	64310-05	140	64314-56-3L	276
64133-3L	277	64255-126-5L	279	64310-38	138	64314-56-5L	276
64133-5L	277	64255-126-7L	279	64310-39	138	64314-56-7L	276
64133-7L	277	64255-127	192	64310-40	138	64315-44	238
64135-3L	277	64255-127-3L	279	64311-06	140	64315-45	238
64135-5L	277	64255-127-5L	279	64311-38	138	64315-46	238
64135-7L	277	64255-127-7L	279	64311-39	138	64315-47	234
64137-3L	277	64255-128	192	64311-40	138	64315-48	234
64137-5L	277	64255-128-3L	279	64311-48	136	64315-49	234
64137-7L	277	64255-128-5L	279	64312-07	140	64315-54	240
64159-110	270	64255-128-7L	279	64312-08	140	64315-55	240
64160-110	270	64262-110	220	64312-41	138	64315-56	240
64162-110	270	64263-110	220	64312-42	138	64316-01	140
64198-110	302	64275-111	84	64312-43	138	64316-02	140
64199-110	302	64275-112	84	64313-09	140	64316-35	138
64200-110	302	64275-113	84	64313-41	138	64316-36	138
64201-110	302	64275-114	84	64313-42	138	64316-37	138
64204-110	304	64275-115	84	64313-43	138	64317-03	140
64205-110	304	64276-111	84	64313-49	136	64317-35	138
64210A	280	64276-112	84	64314-44	238	64317-36	138
64211A	280	64276-113	84	64314-44-3L	276	64317-37	138
64212A	280	64276-114	84	64314-44-5L	276	64317-47	136
64213A	280	64276-115	84	64314-44-7L	276	64317-71	110

Ref	Pag.	Ref	Pag.	Ref	Pag.	Ref	Pag.
65134-72	230	68593-3L	275	70303-110	945	71576-04	620
65134-73	232	68593-5L	275	70305-110	944	71576P-03	776
65134-74	232	68593-7L	275	70459N	956	71576P-04	774
65134-75	232	68594-1L	222	70566N	916	71579-02	800
65134-76	230	68594-3L	275	70567N	916	71579C-03	800
65134-77	230	68594-5L	275	70573B	880	71579C-04	800
66400-101	456	68594-7L	275	70592N	958	71579C-05	798
66400-102	456	68595-1L	222	70593N	958	71579C-06	798
66400-105	456	68595-3L	275	70634-110	918	71579C-07	798
66400-106	456	68595-5L	275	70637-110	918	71579C-09	798
66400-97	456	68595-7L	275	70644-110	910	71579C-11	798
66400-98	456	68596-1L	222	70645-110	910	71579C-13	798
66401-100	458	68596-3L	275	70646-110	910	71584-01	806
66401-103	458	68596-5L	275	70647-110	910	71584-02	602
66401-104	458	68596-7L	275	70660W	954	71584-03	806
66401-107	459	68597-1L	222	70661W	954	71584-04	806
66401-108	459	68597-3L	275	70662W	954	71584-05	804
66401-109	459	68597-5L	275	70665-110	874	71584-06	804
66401-110	459	68597-7L	275	70666-110	874	71584-07	804
66401-99	458	68600-50	198	70686-110	920	71584-08	804
68145-3L	276	68600-51	198	70687-110	920	71584-09	802
68145-5L	276	68604-44	281	70772-110	674	71584-10	802
68145-7L	276	68604-45	281	71489N	962	71584-11	802
68146-3L	276	68604-46	281	71569-01	618	71584-12	802
68146-5L	276	68604-47	281	71569-04	620	71584-13	802
68146-7L	276	68604-48	281	71569-05	616	71584-14	802
68490-01	390	68604-49	281	71569-06	616	71770-110	744
68490-02	390	68604-54	281	71569-07	614	71770V	744
68490-03	390	68604-55	281	71569-08	614	71771-110	744
68492-01	390	68604-56	281	71569-09	612	71771V	744
68492-02	390	68604-62	281	71569-10	612	71898-110	906
68492-03	390	68604-63	281	71569-11	612	71899-110	904
68493-01	390	68604-64	281	71569-12	612	71900-110	904
68493-02	390	68604-65	281	71569-13	612	71901-110	904
68493-03	390	68604-66	281	71569-14	612	71902-110	904
68494-01	390	68604-67	281	71575-01	618	71909-110	906
68494-02	390	68604-68	281	71575-04	620	71910-110	906
68494-03	390	70025-110	748	71575-05	616	71911-110	906
68495-01	390	70162-110	968	71575-06	616	71915-110	908
68495-02	390	70163-110	968	71575-07	614	71916-110	908
68495-03	390	70247-110	696	71575-09	612	71917-110	908
68590-69	228	70248-110	784	71575-11	612	71918-110	908
68590-70	228	70264-110	918	71575-13	612	72311-110	680
68591-1L	222	70267-110	918	71575P-01	776	72312-110	680
68591-3L	275	70268-110	918	71575P-03	776	74155-110	646
68591-5L	275	70269-110	918	71575P-04	774	74156-110	646
68591-7L	275	70270-110	918	71575P-05	772	74427C-01	815
68592-1L	222	70285-110	934	71575P-06	772	74427C-02	815
68592-3L	275	70286-110	934	71575P-07	772	74427C-03	814
68592-5L	275	70294-110	832	71575P-09	772	74427C-04	814
68592-7L	275	70295-110	640	71575P-11	772	74432A-01	854
68593-1L	222	70302-110	945	71576-01	618	74432A-02	854



Ref	Pag.	Ref	Pag.	Ref	Pag.
74432A-03	858	751000D-110	710	75706-2	582
74432A-04	856	751001D-110	710	75707-2	582
74433S-01	669	751002D-110	710	75708-2	582
74433S-02	668	751010D-110	710	75708-233	764
74433S-03	669	751011D-110	710	75708-233P	765
74433S-04	668	751012D-110	710	75709-2	582
74434B-01	671	751020D-110	710	75709-233	764
74434B-02	670	751021D-110	710	75709-233P	765
74434B-03	671	751022D-110	710	75711-1	586
74434B-04	670	751100D-110	712	75711-2	586
74435F2-02	724	751101D-110	712	75712-1	584
74435F2-03	728	751102D-110	712	75712-2	584
74435F2-04	726	751110D-110	712	75714-2	581
74436F3-02	724	751111D-110	712	75756-110	841
74436F3-03	728	751112D-110	712	75757-110	841
74436F3-04	726	751120D-110	712	75758-01-110	808
750000D-110	702	751121D-110	712	75758-110	826
750001D-110	702	751122D-110	712		
750002D-110	702	751200D-110	714		
750010D-110	702	751201D-110	714		
750011D-110	702	751202D-110	714		
750012D-110	702	751210D-110	714		
750020D-110	702	751211D-110	714		
750021D-110	702	751212D-110	714		
750022D-110	702	751220D-110	714		
750100D-110	704	751221D-110	714		
750101D-110	704	751222D-110	714		
750102D-110	704	751300D-110	716		
750110D-110	704	751301D-110	716		
750111D-110	704	751302D-110	716		
750112D-110	704	751310D-110	716		
750120D-110	704	751311D-110	716		
750121D-110	704	751312D-110	716		
750122D-110	704	751320D-110	716		
750200D-110	706	751321D-110	716		
750201D-110	706	751322D-110	716		
750202D-110	706	75300F	739		
750210D-110	706	75300H	739		
750211D-110	706	75300S	739		
750212D-110	706	75300V	739		
750220D-110	706	75522-110	662		
750221D-110	706	75523-110	662		
750222D-110	706	75524-110	722		
750300D-110	708	75550-110	638		
750301D-110	708	75551-110	638		
750302D-110	708	75552-110	638		
750310D-110	708	75553-110	638		
750311D-110	708	75556-110	782		
750312D-110	708	75557-110	782		
750320D-110	708	75607-110	720		
750321D-110	708	75703-2	588		
750322D-110	708	75703-233	740		





# ARCHITECTURAL





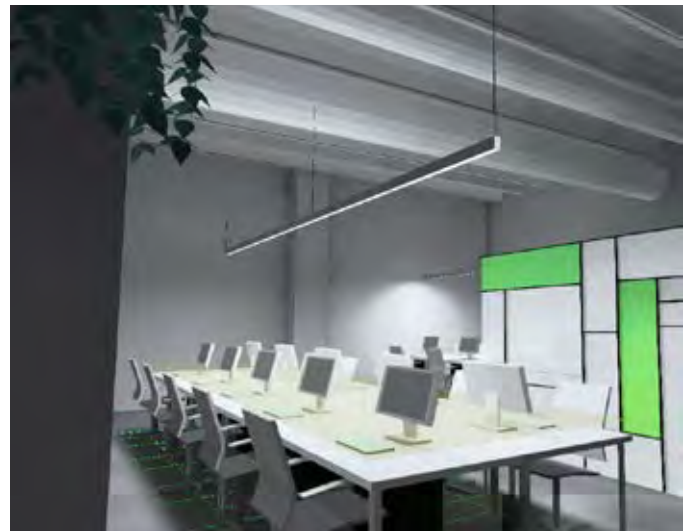
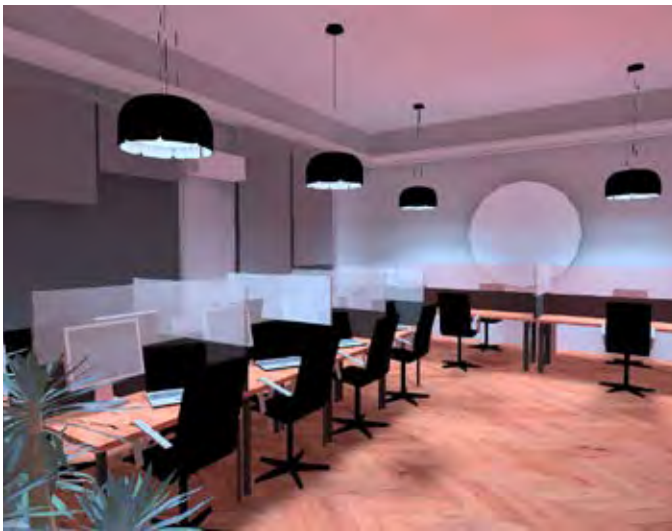
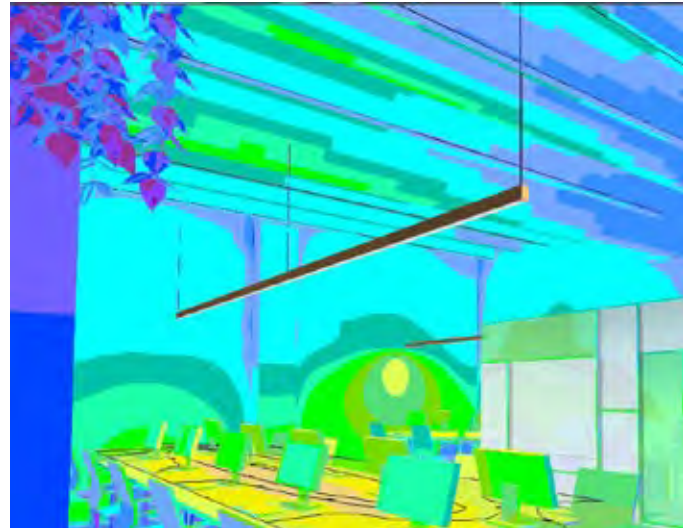
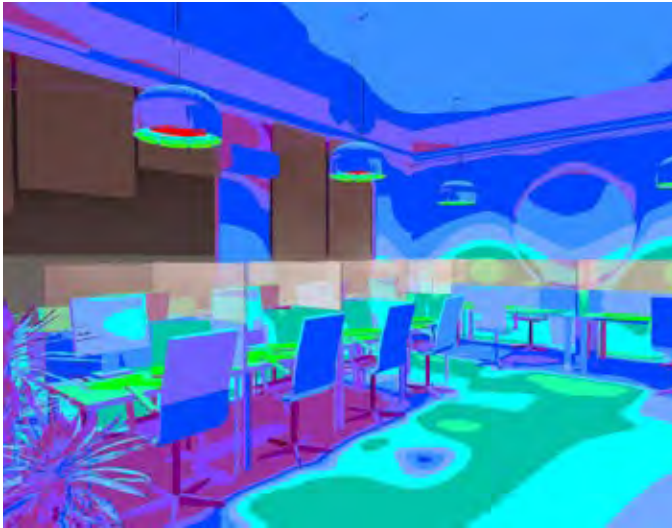

At Faro Barcelona we put at your disposal our great team of lighting and interior designers to advise you in your lighting projects, both with the interpretation of the client's needs, the calculations and documentation of the project, and with personalised advice and a complete follow-up of the project from conceptualisation to implementation. All this with a special sensitivity to the care of the environment, architectural enhancement and customer satisfaction, taking into account aesthetic values and trends.

En Faro Barcelona ponemos a tu disposición nuestro gran equipo de expertos en lighting design e interiorismo y te acompañamos en tus proyectos de iluminación, tanto con la interpretación de las necesidades del cliente, la realización de cálculos y documentación del proyecto junto con una asesoría personalizada y un seguimiento completo del proyecto desde la conceptualización a la implementación. Todo ello con una sensibilidad especial en el cuidado del entorno, realce arquitectónico y satisfacción del cliente, teniendo en cuenta valores estéticos y de tendencias.

# LIGHTING PROJECTS

PROYECTOS DE ILUMINACIÓN

**Need consulting for your project?**  
¿Necesitas asesoramiento para tu proyecto?





Harnessing our expertise and professionalism, we customise products and develop made-to-order and unique solutions.

# CUSTOM & SPECIAL DEVELOPMENTS

PERSONALIZACIONES Y DESARROLLOS ESPECIALES

Nuestra experiencia y profesionalidad nos permite realizar personalizaciones de producto así como desarrollar soluciones únicas para cada proyecto.



## WELL-BEING

Your customers are looking for pleasant, comfortable and enjoyable sensations and experiences that can be easily programmed and guaranteed.



## EL BIENESTAR DE LAS PERSONAS

Tus clientes buscan sensaciones y experiencias agradables, cómodas y placenteras que puedan ser fácilmente programadas y garantizadas.

## EFFICIENCY AND SUSTAINABILITY

Scheduling and automation allow us to minimise energy costs and therefore the impact on the environment.



## EFICIENCIA Y SOSTENIBILIDAD

La programación y la automatización nos permiten minimizar los costes energéticos y el impacto en el medio ambiente.

## FLEXIBILITY AND CUSTOMIZATION

Get the maximum level of flexibility in your project. Spaces with customised configuration settings in a convenient and simple way.



## FLEXIBILIDAD Y CUSTOMIZACIÓN

Obtén el máximo nivel de flexibilidad en tu proyecto. Espacios con ajustes de configuración personalizados de forma cómoda y sencilla.

## GUARANTEE THE BEST EXPERIENCE

Technology helps us to meet the needs and demands of our customers and thus ensure a better experience in the spaces they live in.



## LA MEJOR EXPERIENCIA

La tecnología nos ayuda a satisfacer las necesidades y exigencias de nuestros clientes y garantizar, así, una mejor experiencia en los espacios que habitan.

At Faro Barcelona we know the benefits of quality light at the service of people's well-being. For this reason, we design luminaires and connectivity solutions that apply the latest technology to achieve this purpose.

# CONTROL & CONNECTIVITY

SMART LIGHTING

En Faro Barcelona tenemos muy presente los beneficios de una luz de calidad al servicio del bienestar de las personas. Por ello, diseñamos luminarias y soluciones de conectividad que aplican la última tecnología para conseguir este propósito.

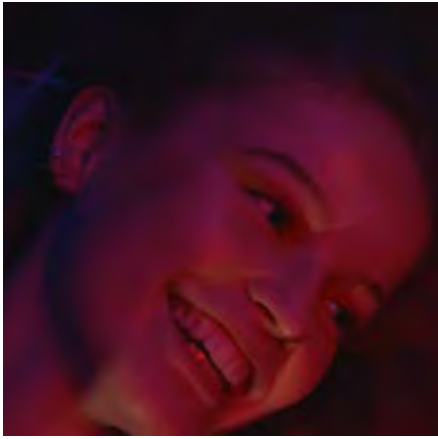

**INCREASES PHYSICAL AND EMOTIONAL WELL-BEING**  
**INCREMENTA EL BIENESTAR FÍSICO Y EMOCIONAL**



**IMPROVES SLEEP CYCLE**  
**MEJORA EL CICLO DEL SUEÑO**



**INCREASES EFFICIENCY**  
**MEJORA EL RENDIMIENTO**



Light profoundly affects our well-being. Our products prioritize the non-visual impact of light, promoting health. We emphasize Human Centric Lighting (HCL), replicating natural light rhythms. Artificial lighting mirrors sunlight's movement, intensity, and color, aligning with our circadian cycle.

Understanding light as a crucial life element, we develop solutions for holistic health, ensuring our well-being aligns with the dynamic qualities of natural light.

# INTEGRATIVE LIGHTING

LUZ INTEGRADORA

La luz tiene un impacto directo en nuestro estado físico y emocional. Nuestros productos y soluciones se desarrollan teniendo en cuenta los efectos no visuales de la luz, en beneficio de la salud y el bienestar de las personas.

Aplicamos el concepto de Iluminación Centrada en el Ser Humano (HCL) en nuestras soluciones, mejorando los efectos que la luz tiene en las personas y reproduciendo los ritmos de la luz natural en la iluminación artificial. Nuestro ciclo circadiano puede ser reproducido con iluminación artificial y dinámica que corresponda al movimiento, intensidad y color del sol.



## PHOTOBIOLOGICAL RISK

We develop our luminaires by selecting the highest quality light sources and working the optical compartments in order to be able to offer RG0 products, free of photobiological risk.

The European standard for photobiological safety EN 62471 establishes a method for assessing the risk of eye or skin damage from a lamp or luminaire.



## RIESGO FOTBIOLÓGICO

Desarrollamos nuestras luminarias seleccionando fuentes de luz de la máxima calidad y trabajando los bloques ópticos para poder ofrecer productos RG0, exentos de riesgo fotobiológico.

La norma europea de seguridad fotobiológica EN 62471 establece un método para evaluar el riesgo de daño ocular o dermatológico de una lámpara o luminaria.

## FLICKER FREE

Flicker is a visible and repetitive change in light intensity caused mostly by voltage fluctuations. At Faro Barcelona we select our drivers with the guarantee of leading European brands, ensuring a good regulation and adjustment of the electricity flow, without temperature changes altering its operation.



## LIBRE DE FLICKER

El flicker es un cambio visible y repetitivo en la intensidad de la luz causado en su mayoría por las fluctuaciones de voltaje. En Faro Barcelona seleccionamos nuestros drivers con la garantía de primeras marcas europeas, asegurando una buena regulación y ajuste del flujo de electricidad, sin que los cambios de temperatura alteren su funcionamiento.

## CRI

The colour rendering index (CRI) is a quantitative measure that indicates the ability of a light source to faithfully reproduce colours compared to a natural light source.

Our luminaires have high CRI to ensure the best colour rendering.



## IRC

El índice de reproducción cromática (IRC) es una medida cuantitativa que indica la capacidad que tiene una fuente de luz para reproducir fielmente los colores en comparación con una fuente de luz natural.

Nuestras luminarias presentan altos IRC para garantizar la mejor reproducción cromática.

## UGR

Glare negatively affects people's well-being and productivity.

Our solutions guarantee a high level of visual comfort - with diffuser options microprism, precise lens and optics combinations - for better light control and glare reduction.



## UGR

El deslumbramiento afecta negativamente al bienestar y la productividad de las personas. Nuestras soluciones garantizan un alto confort visual -con opciones de difusor microprismático, combinación precisa de lentes y ópticas- para un mejor control lumínico y reducción del deslumbramiento.

Light is an indispensable element in the perception of our environment: it influences how we perceive space and what emotions it generates in us. It is the regulator of our biorhythms, capable of stimulating, relaxing or activating our organism, directly affecting our well-being-mood, sleep cycles, performance.

# HEALTHY LIGHTING

ILUMINACIÓN SALUDABLE

La luz es un elemento indispensable en la percepción de nuestro entorno: influye en cómo percibimos el espacio y qué emociones nos genera. Es la reguladora de nuestros biorritmos, capaz de estimular, relajar o activar nuestro organismo, afectando de forma directa a nuestro bienestar -estado de ánimo, ciclos de sueño, rendimiento-.



Nuestros productos LEAF son luminarias especiales diseñadas para potenciar el crecimiento de plantas de interior.  
 Estos productos resultan ideales para crear entornos biofílicos con escasa iluminación natural.  
 Our LEAF products are special luminaires designed to enhance the growth of indoor plants.  
 These products are ideal for creating biophilic environments with low natural light.

## BIOPHILIA

Connecting with nature is crucial for well-being. We've developed models promoting biophilic indoor design, integrating nature elements for calmness and well-being. Common in offices, restaurants, and hotels, green spaces require special lighting for vegetation maintenance.



## BIOFILIA

Conectar con la naturaleza es crucial para el bienestar. Hemos desarrollado modelos que promueven el diseño biofílico en interiores, integrando elementos naturales para la calma y el bienestar. Común en oficinas, restaurantes y hoteles, los espacios verdes requieren iluminación especial para el mantenimiento de la vegetación.

## LIGHT SPECTRUM

LEDs allow precise light spectrum customization for plants, meeting varied growth stages. Tailor colors to enhance vegetative growth or encourage flowering and fruiting. Typically, red and blue lights promote growth, while green and white lights aid in flowering and fruit development.



## ESPECTRO DE LUZ

Los LEDs permiten la personalización precisa del espectro de luz emitida para las plantas, cubriendo diversas etapas de crecimiento. Adapta los colores para potenciar el crecimiento vegetativo o fomentar la floración y fructificación. Por lo general, las luces rojas y azules impulsan el crecimiento, mientras que las luces verdes y blancas ayudan en el desarrollo de flores y frutos.

## PHOTON FLUX DENSITY

PFD (photons/m<sup>2</sup>/s) is a crucial metric, measuring light available for photosynthesis with consideration for the spectrum's impact on plant growth. Typically falling within the range of 50-150 μmol/m<sup>2</sup>/s, this metric guides the provision of optimal light for healthy growth.



## DENSIDAD DE FLUJO DE FOTONES

PFD (fotones/m<sup>2</sup>/s) es una métrica crucial, midiendo la luz disponible para la fotosíntesis con consideración del impacto del espectro en el crecimiento de las plantas. Generalmente, oscilando entre 50-150 μmol/m<sup>2</sup>/s, esta métrica guía la provisión de luz óptima para el crecimiento saludable.

## FEATURES OF OUR LEAF LIGHT SOURCES

Higher infrared emission (> 700 nm): Benefits photosynthesis and growth. Green emission (500-560 nm): Essential for vegetative growth, absorbed by chloroplasts, triggering physiological responses for healthy plant development.



## CARACTERÍSTICAS DE NUESTRAS FUENTES DE LUZ LEAF

Mayor emisión infrarroja (> 700 nm): Beneficia la fotosíntesis y el crecimiento. Emisión verde (500-560 nm): Esencial para el crecimiento vegetativo, absorbida por los cloroplastos, desencadenando respuestas fisiológicas para el desarrollo saludable de las plantas.

SE TRABAJA EN LA ÚLTIMA FASE, PAGINACIÓN

LEAF

LEAF products: Target on page 35. VIA on page 67  
 Productos LEAF: Target página 35. VIA página 67

1196



Light is essential not only for human well-being but also for plant growth in biophilic spaces. Its role encompasses supporting photosynthesis and plant development, acting as a dual regulator by influencing human biorhythms and emotional states while nourishing the vitality of plants. This harmonious interaction enhances the overall biophilic experience.

# BIOPHILIC SPACES

ESPACIOS BIOFÍLICOS

La luz es esencial tanto para el bienestar humano como para el crecimiento de las plantas en espacios biofílicos. Su papel abarca el respaldo de la fotosíntesis y el desarrollo vegetal, actuando como regulador dual al influir en biorritmos y estados emocionales humanos, al mismo tiempo que nutre la vitalidad de las plantas. Esta interacción armónica potencia la experiencia





# TRACKLIGHTS

Less is more. The design of the TARGET track projector achieves the minimum expression of visual volume, making the place appear spacious and bringing the architecture and the elements to be lit to the forefront. Its wide range of colour temperature, different optics and high CRI options makes it a perfect option for commercial spaces, hotels, restaurants and retail.

Menos es más. El diseño del proyector a carril TARGET logra la mínima expresión del volumen visual, dotando de amplitud al lugar y cediendo el protagonismo a la arquitectura y los elementos a iluminar. Su amplia gama de temperaturas de color, diversas ópticas y opciones de alto IRC lo convierten en una opción perfecta para espacios comerciales, hoteles, restauración y retail.



# TARGET







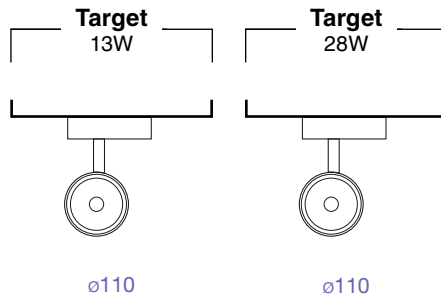

**FINISH**  
Acabado

● **Black**  
Negro

○ **White**  
Blanco

**COLOR TEMPERATURE**  
Temperatura de color

2700K CRI90

3000K CRI90

4000K CRI90

2700K CRI97

3000K CRI97

4000K CRI97

MEAT

BREAD

FASHION

**LEAF \***

**BEAM ANGLE**  
Ángulo de apertura

15°

35°

**ACCESSORIES**  
Accesorios



Honeycomb



Striped Glass



Long Shoot

\* Leaf. More information on page 31

\* Leaf. Más información en la página 31

# Highlights



## Accessory

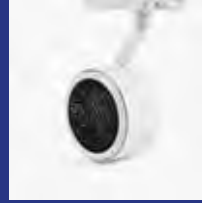

Honeycomb



Long Snout



Striped Glass



**Built-in track**  
Equipo built-in en adaptador



**High CRI**  
Alto IRC

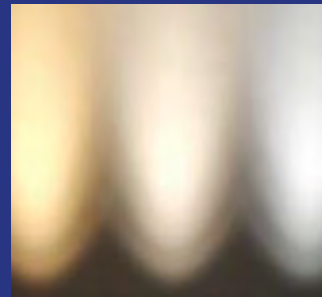

**Several color temperatures**  
Varias temperaturas de color



**LEAF: Light source for plant growth.**  
**LEAF:** Fuente de luz para crecimiento de plantas.



**Need consulting  
for your project?**  
¿Necesitas  
asesoramiento  
para tu proyecto?







Honeycomb



Long Snoot



Striped Glass



Striped Glass

# Accessories

Honeycomb	Long Snoot	Striped Glass
● 011400098		● 011400097
● 011400096	● 011400099	● 011400095



**Restaurant**

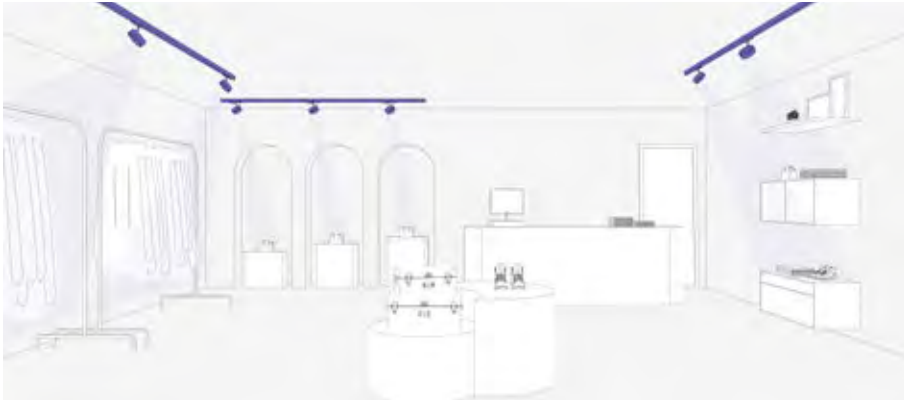

**Retail**



**Office**

## Beam Angle



**15°**



**35°**

# TARGET 13W



- incl.
- 355°
- 90°
- 50.000hs L70 / B10
- MacAdam 2&3
- 110V
- 50 / 60Hz
- 650°C

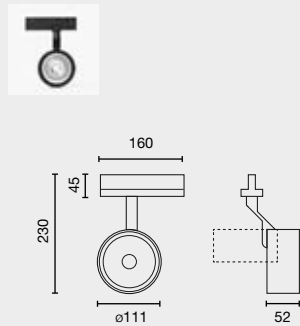

Family	Color T°	Beam Angle	Finish	Volt.
0214 Target 13W	927 2700K CRI90	1 15°	1 White	-110 110V
	930 3000K CRI90	3 35°	2 Black	
	940 4000K CRI90			
	X27 2700K CRI97			
	X30 3000K CRI97			
	X40 4000K CRI97			
	MT MEAT			
	BR BREAD			
	FS FASHION			
	LF LEAF			

0214 927 1 1 -110

Example 021492711-110 — Target13W 2700K CRI90 15° White 110V

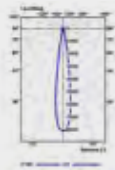

15°

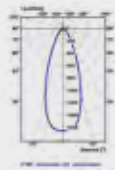

35°

Option	Color T°	CRI	Power	Lumen Output	Beam Angle
927	2700K	90	13W	970 / 1048lm	15° / 35°
x27		97	13W	872 / 943lm	15° / 35°
930	3000K	90	13W	1000 / 1080lm	15° / 35°
x30		97	13W	900 / 972lm	15° / 35°
940	4000K	90	13W	1029 / 1113lm	15° / 35°
x40		97	13W	927 / 1001lm	15° / 35°
MT	3100K	-	13W	1143 / 1226lm	15° / 35°
BR	2500K	-	13W	847 / 909lm	15° / 35°
FS	3100K	-	13W	1168 / 1253lm	15° / 35°
LF	2700K	-	13W	665 / 693lm	15° / 35°





# TARGET 28W

incl. 355° 90° 50.000hs L70 / B10 MacAdam 2&3 110V 50 / 60Hz 650°C

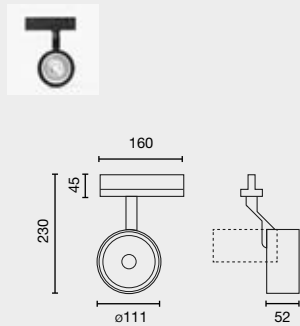

Family	Color T°	Beam Angle	Finish	Control System
0114 Target 28W	927 2700K CRI90	1 15°	1 White	-110 110V
	930 3000K CRI90	3 35°	2 Black	
	940 4000K CRI90			
	X27 2700K CRI97			
	X30 3000K CRI97			
	X40 4000K CRI97			
	MT MEAT			
	BR BREAD			
	FS FASHION			
	LF LEAF			

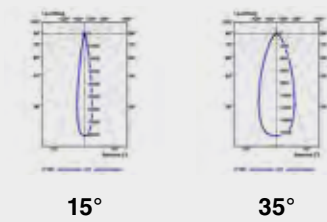

Option	Color T°	CRI	Power	Lumen Output	Beam Angle
927	2700K	90	28W	2311lm / 2157lm	15° / 35°
X27		97	28W	2079lm / 1941lm	15° / 35°
930	3000K	90	28W	2382lm / 2224lm	15° / 35°
X30		97	28W	2144lm / 2001lm	15° / 35°
940	4000K	90	28W	2453lm / 2291lm	15° / 35°
X40		97	28W	2208lm / 2061lm	15° / 35°
MT	3100K	-	28W	2723lm / 2523lm	15° / 35°
BR	2500K	-	28W	2018lm / 1871lm	15° / 35°
FS	3100K	-	28W	2783lm / 2579lm	15° / 35°
LF	2700K	-	28W	1584lm / 1426lm	15° / 35°



Track Lights

The FOST TRACK family of track projectors was born to meet the need to accentuate what needs to be highlighted. A minimalist design that is easy to integrate into any space, bringing the architecture to the forefront. The location of the driver in the actual track adaptor facilitates this integration.

La familia de proyectores a carril FOST TRACK nace para dar respuesta a la necesidad de poner acento a lo que debe ser destacado. Un diseño minimalista de fácil integración en cualquier espacio dando protagonismo a la arquitectura. La ubicación del driver en el propio adaptador a carril facilita esta integración.



# FOST



# TRACK





## FOST Collection



Recessed  
171



Pulldown  
181



Ceiling  
277



Surface  
267



Pendant  
323

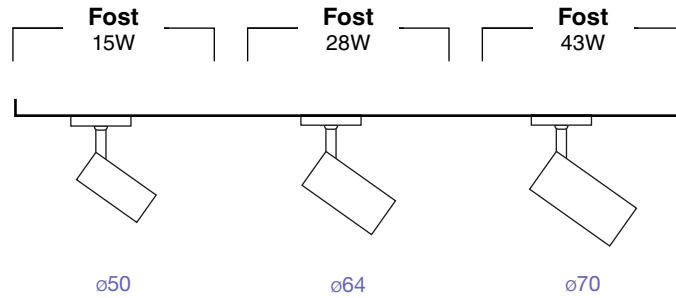

**FINISH**  
Acabado

● **Black**  
Negro

○ **White**  
Blanco





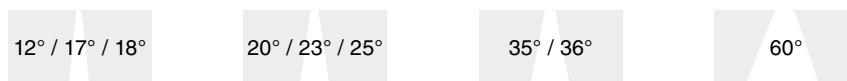

**COLOR TEMPERATURE**  
Temperatura de color

2700K CRI90	3000K CRI90	4000K CRI90
2700K CRI97	3000K CRI97	4000K CRI97
MEAT	BREAD	FASHION

**BEAM ANGLE**  
Ángulo de apertura



**ACCESSORIES**  
Accesorios

- |   |   |   |
|---|---|---|
|  |  |  |
| Honeycomb   | Striped glass   | Spread Glass  |
|  |  |  |
| White Ring  | Copper Ring   | Snoot   |

# Highlights



**Its versatility of sizes and optics makes it an ideal solution for commercial spaces, hotels, restaurants, retail and even domestic spaces due to its colour temperature and CRI options.**

Su versatilidad en tamaños y ópticas lo convierten en una solución ideal para espacios comerciales, hoteles, restaurantes, retail e incluso espacios domésticos por sus opciones en temperatura de color y IRC.



**Different sizes**  
Diversos tamaños



**Built-in track**  
Equipo built-in en adaptador



**High CRI**  
Alto IRC

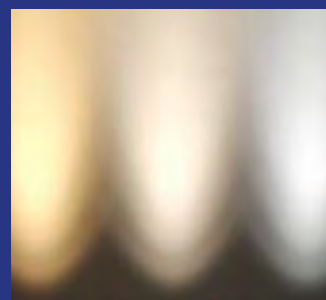

**Several color temperatures**  
Varias temperaturas de color







White Ring



Copper Ring



Striped Glass



Long Snoot

**Its multiple accessories and combinations facilitate the product's personalisation, giving it certain architectural relevance and at the same time making it possible to modify the beam or reduce glare.**

Sus múltiples accesorios y combinaciones facilitan la personalización del producto que hace posible la modificación de haz o reducir el deslumbramiento.



Spread Glass



Honeycomb



Without accessory

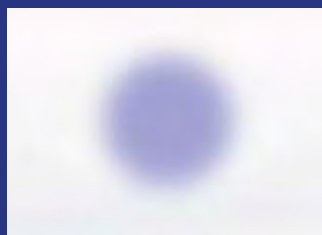

Spread Glass



Striped Glass

# Accesorios

	Honeycomb	White Ring	Copper Ring	Spread Glass	Long Snoot	Striped Glass
ø40	-	011500099	011500098	-	-	-
ø50	-	011600099	011600098	-	-	-
ø64	011700094	011700099	011700098	011700097	011700095	011700096
ø70	011800094	011800099	011800098	011800097	011800095	011800096



**Restaurant**

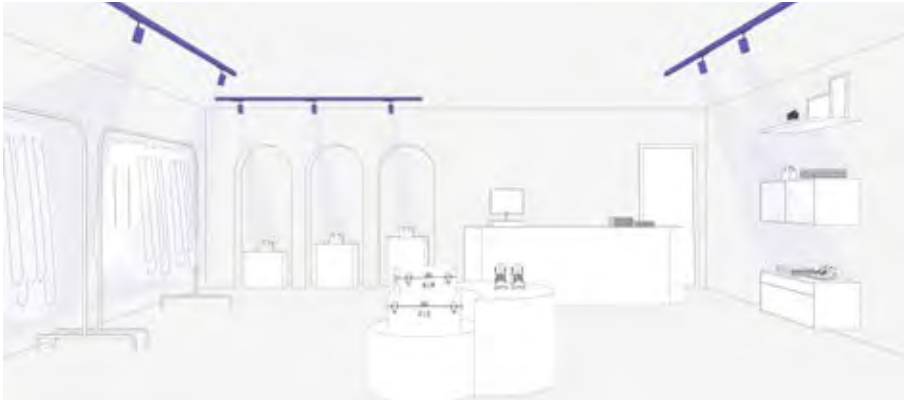

**Retail**

## Beam Angle



**12/17/18°**

**20/23/25°**

**35/36°**

**60°**

# FOST TRACK 50

incl. 355° 90° 50.000hs L70 / B10 MacAdam 2&3 110V 50 / 60Hz 650°C

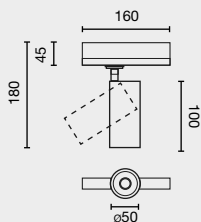

Family	Color T°	Beam Angle	Finish	Volt.
0116 Fost Track ø50 15W	927 2700K CRI90	1 20° 2 26° 3 36°	1 White	-110 110V
	930 3000K CRI90		2 Black	
	940 4000K CRI90			
	X27 2700K CRI97			
	X30 3000K CRI97			
	X40 4000K CRI97			

0116 927 1 1 -110

Example 011692711-110 — Fost Track 50 2700K CRI90 20° White 110V

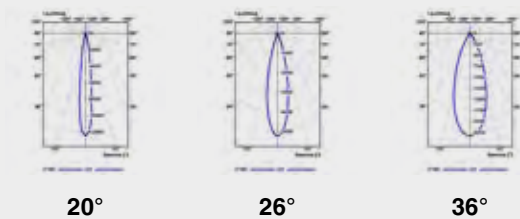

Option	Color T°	CRI	Power	Lumen Output	Beam Angle
927	2700K	90	15W	1235lm / 1257lm / 1303lm	20° / 26° / 36°
X27		97	15W	1111lm / 1131lm / 1172lm	20° / 26° / 36°
930	3000K	90	15W	1273lm / 1295lm / 1343lm	20° / 26° / 36°
X30		97	15W	1146lm / 1166lm / 1209lm	20° / 26° / 36°
940	4000K	90	15W	1311lm / 1334lm / 1383lm	20° / 26° / 36°
X40		97	15W	1180lm / 1201lm / 1245lm	20° / 26° / 36°

Thanks to EMMME Studio | Photo by Lupe Clemente





# FOST TRACK 64

incl. 355° 90° 50.000hs L70 / B10 MacAdam 2&3 110V 50 / 60Hz 650°C

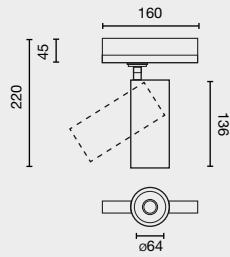

Family	Color T°	Beam Angle	Finish	Volt.
<b>0117</b> Fost Track ø64 28W	<b>927</b> 2700K CRI90 <b>930</b> 3000K CRI90 <b>940</b> 4000K CRI90 <b>X27</b> 2700K CRI97 <b>X30</b> 3000K CRI97 <b>X40</b> 4000K CRI97	<b>1</b> 17° <b>2</b> 25° <b>3</b> 35° <b>6</b> 60°	<b>1</b> White <b>2</b> Black	<b>-110</b> 110V

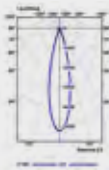

17°

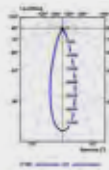

25°

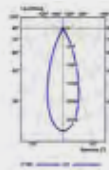

35°

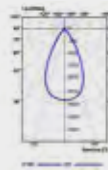

60°

Option	Color T°	CRI	Power	Lumen Output	Beam Angle
927	2700K	90	28W	2982lm / 2987lm / 2732lm / 2270lm	17° / 25° / 35° / 60°
X27		97	28W	2684lm / 2688lm / 2459lm / 2043lm	17° / 25° / 35° / 60°
930	3000K	90	28W	3075lm / 3080lm / 2817lm / 2341lm	17° / 25° / 35° / 60°
X30		97	28W	2767lm / 2771lm / 2535lm / 2107lm	17° / 25° / 35° / 60°
940	4000K	90	28W	3167lm / 3172lm / 2902lm / 2412lm	17° / 25° / 35° / 60°
X40		97	28W	2850lm / 2855lm / 2611lm / 2170lm	17° / 25° / 35° / 60°

# FOST TRACK 70

incl. 355° 90° 50.000hs L70 / B10 MacAdam 2&3 110V 50 / 60Hz 650°C

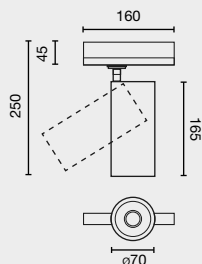

Family	Color T°	Beam Angle	Finish	Volt.												
0118 Fost Track ø70 43W	927 2700K CRI90	<table border="1"> <tr><td>1</td><td>18°</td></tr> <tr><td>2</td><td>23°</td></tr> <tr><td>3</td><td>36°</td></tr> <tr><td>6</td><td>60°</td></tr> </table>	1	18°	2	23°	3	36°	6	60°	<table border="1"> <tr><td>1</td><td>White</td></tr> <tr><td>2</td><td>Black</td></tr> </table>	1	White	2	Black	-110 110V
	1		18°													
	2		23°													
	3		36°													
	6	60°														
	1	White														
	2	Black														
	930 3000K CRI90															
	940 4000K CRI90															
	X27 2700K CRI97															
X30 3000K CRI97																
X40 4000K CRI97																
MT MEAT																
BR BREAD																
FS FASHION																

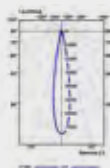

18°

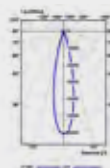

23°



36°

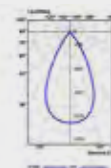

60°

Option	Color T°	CRI	Power	Lumen Output	Beam Angle
927	2700K	90	43W	2954lm / 2931lm / 2920lm / 2800lm	18° / 23° / 36° / 60°
X27		97	43W	2658lm / 2638lm / 2628lm / 2520lm	18° / 23° / 36° / 60°
930	3000K	90	43W	3045lm / 3022lm / 3010lm / 2886lm	18° / 23° / 36° / 60°
X30		97	43W	2741lm / 2720lm / 2709lm / 2597lm	18° / 23° / 36° / 60°
940	4000K	90	43W	3136lm / 3113lm / 3100lm / 2972lm	18° / 23° / 36° / 60°
X40		97	43W	2823lm / 2801lm / 2790lm / 2675lm	18° / 23° / 36° / 60°
MT	-	-	43W	2165lm / 2149lm / 2140lm / 2052lm	18° / 23° / 36° / 60°
BR	-	-	43W	2921lm / 2899lm / 2888lm / 2769lm	18° / 23° / 36° / 60°
FS	-	-	43W	2998lm / 2976lm / 2964lm / 2842lm	18° / 23° / 36° / 60°



The image features a close-up of a lighting track system. A black track is visible, with a wooden diffuser block attached to it. The diffuser is made of several layers of wood and has a series of circular holes on its side. The text 'BLIT TRACK' is overlaid on the image in a large, bold, black font. The background is a plain, light-colored surface.

# BLIT TRACK

BLIT TRACK is a versatile solution that provides flexibility and adaptability for various lighting applications. Designed to integrate into track lighting systems, it allows for precise light direction. Its elegant design enhances any environment and offers soft, ambient lighting that creates a cozy atmosphere.

BLIT TRACK es una solución versátil que proporciona flexibilidad y adaptabilidad para diversas aplicaciones de iluminación. Diseñado para integrarse en sistemas de iluminación en carril, permite dirigir la luz de manera precisa. Su diseño elegante realza cualquier entorno y ofrece una iluminación suave y ambiental que crea una atmósfera acogedora.





**BLIT Collection**



Surface  
241

1226

**Blit 210mm**  
20W

**Blit 300mm**  
33W

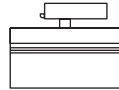

---

**FINISH**  
Acabado

● **Black**  
Negro

○ **White**  
Blanco

---

**COLOR TEMPERATURE**  
Temperatura de color

2700K CRI90

3000K CRI90

4000K CRI90

---

**BEAM ANGLE**  
Ángulo de apertura

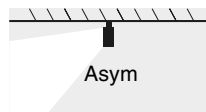

# Highlights

Available in two power options and made entirely of aluminum and glass, BLIT TRACK provides general illumination through indirect light. Its minimalist design makes it perfect for complementing other track luminaires, such as projectors or linear lights, in environments like restaurants or commercial spaces.

Disponible en dos potencias, y fabricado íntegramente de aluminio y cristal, BLIT TRACK ofrece una iluminación general a través de luz indirecta. Su diseño minimalista lo hace perfecto para complementar otras luminarias de carril, como proyectores o luces lineales, en entornos como restaurantes o espacios comerciales.



**High CRI**  
Alto IRC



**High-quality materials**  
Materiales de alta calidad



**Minimal design**  
Diseño minimalista



**Restaurant**

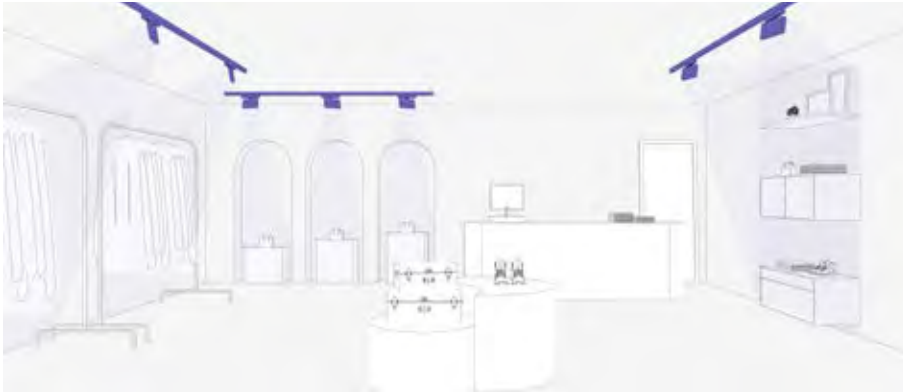

**Retail**

## Beam Angle



**Asym°**



# BLIT TRACK

incl. 355° 30° 50.000hs L80 / B10 MacAdam 3 110V 50 / 60Hz 850°C

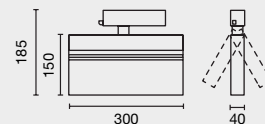
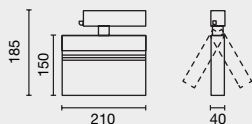

Family	Color T°	Beam Angle	Finish	Volt.
<b>0127</b> Blit track 210mm 20W	<b>927</b> 2700K CRI90	<b>9</b> Asym	<b>1</b> White	<b>-110</b> 110V
<b>0128</b> Blit track 300mm 33W	<b>930</b> 3000K CRI90		<b>2</b> Black	
	<b>940</b> 4000K CRI90			

**0127**                      **927**                      **9**                      **1**                      **-110**

Example **012792791-110**— Blit track 210mm 20W 2700K CRI90 White 110V

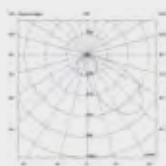

## Asym

Option	Color T°	CRI	Power	Lumen Output	Beam Angle
927	2700K	90	20w	1633	Asym
		90	33w	3412	Asym
930	3000K	90	20w	1684	Asym
		90	33w	3517	Asym
940	4000K	90	20w	1734	Asym
		90	33w	3623	Asym



VIA EVO TRACK is a linear luminaire designed to seamlessly integrate into three-phase track systems. When combined with our other track luminaires, it becomes an efficient solution for providing general lighting in various spaces. It offers three different color temperatures and also comes in Tuneable White and UGR versions, allowing for lighting adjustment to meet specific needs.

VIA EVO TRACK es una luminaria lineal diseñada para adaptarse perfectamente a sistemas de carriles trifásicos. Cuando se combina con otras de nuestras luminarias de carril, se convierte en una solución eficiente para proporcionar iluminación general en espacios diversos. Ofrece tres temperaturas de color diferentes, además de contar con versiones Tuneable White y UGR, lo que permite ajustar la iluminación y satisfacer necesidades específicas.



# VIA

# TRACK







VIA Collection



System  
369

1234

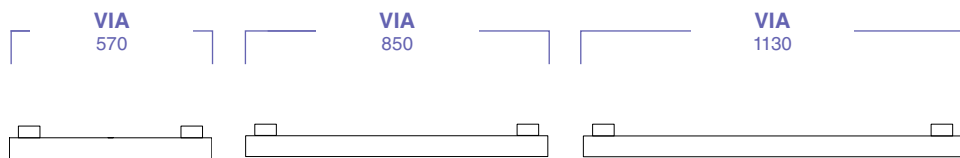

**FINISH**  
Acabado

**Black**  
Negro

**White**  
Blanco

**COLOR TEMPERATURE**  
Temperatura de color

3000K CRI80

4000K CRI80

2700-6500K

LEAF\*

**DIFFUSER**  
Difusor



Opal



Microprisma



UGR

**CONTROL SYSTEM**  
Sistema de Control



\* Leaf. More information on page 31  
\* Leaf. Más información en la página 31

# Highlights

Offering three different sizes and a variety of power options to adapt to the lighting needs of each space, VIA EVO TRACK is also available in UGR versions, ideal for office environments.

Ofreciendo tres tamaños diferentes y una variedad de potencias para adaptarse a las necesidades lumínicas de cada espacio, VIA EVO TRACK también está disponible en versiones UGR, ideales para entornos de oficina.



**LEAF: Light source for plant growth.**

**LEAF:** Fuente de luz para crecimiento de plantas.



**Tunable white**

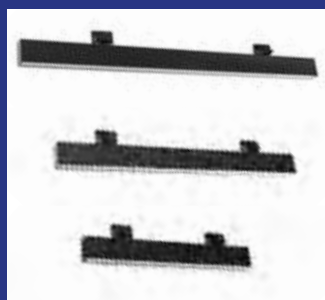

**Different sizes**  
Diversos tamaños

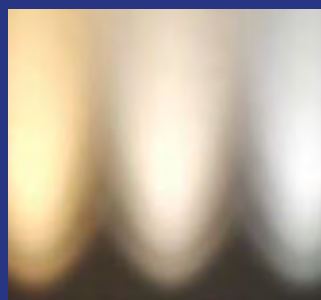

**Several color temperatures**  
Varias temperaturas de color

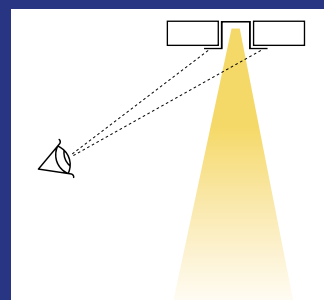

**UGR<19**



**Retail**



**Office**



**Microprisma**



**90°**



**Opal**



**110°**



**UGR**



**50°**



**80°**



**Asym°**



## VIA TRACK 570

incl. DIM 50.000hs L80/B10 MacAdam 3 110V 50 / 60Hz 650°C

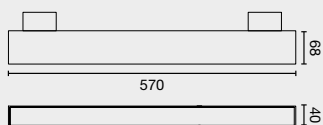

Family	Power	Finish	Control System	Diffuser	Volt.
0410T Via Evo	590	Track 15W 3000K CRI80	1 White	ON/OFF	-110 110V
	570	Track 25W 3000K CRI80	2 Black	D DALI	
	680	Track 15W 4000K CRI80		U Opal	Microprisma
	660	Track 25W 4000K CRI80		U Microprisma	

0410T 570 1 D -110

Example 0410T5701D-110 — Via Evo Track 570 mm 25W 3000K White DALI Opal White 110V

## VIA TRACK 850

incl. DIM 50.000hs L80/B10 MacAdam 3 110V 50 / 60Hz 650°C

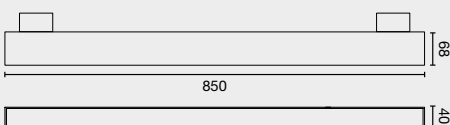
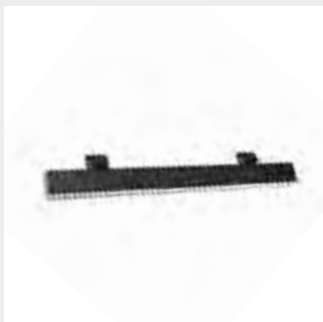



Family	Power	Finish	Control System	Diffuser	Volt.
0410T Via Evo	560	Track 20W 3000K CRI80	1 White	ON/OFF	-110 110V
	540	Track 38W 3000K CRI80	2 Black	D DALI	
	650	Track 20W 4000K CRI80		U Opal	Microprisma
	630	Surface 38W 4000K CRI80		U Microprisma	

# VIA TRACK 1130

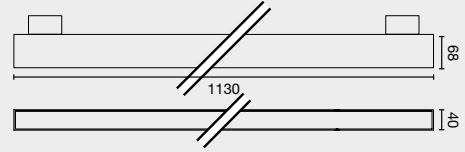
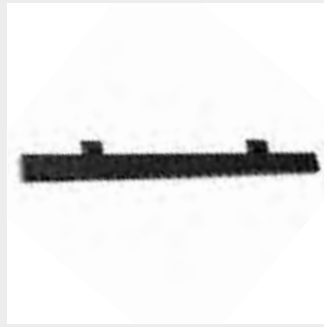
 incl.  DIM  50.000hs  L80/B10  MacAdam 3  110V  50 / 60Hz  650°C  UGR 16



Family	Power	Finish	Control System	Diffuser	Volt.
0410T Via Evo	530	Track 27W 3000K CRI80	<input type="checkbox"/> ON/OFF <input checked="" type="checkbox"/> 	<input type="checkbox"/> Opal <input checked="" type="checkbox"/> Microprisma	-110 110V
	510	Track 51W 3000K CRI80			
	620	Track 27W 4000K CRI80			
	600	Track 51W 4000K CRI80			
	LF	Track Leaf 33W			
	1	White			
	2	Black			
0410T Via Evo	110	Track UGR 32W 3000K CRI80	<input type="checkbox"/> ON/OFF <input checked="" type="checkbox"/> 	<input checked="" type="checkbox"/> UGR<19 80° <input type="checkbox"/> UGR<16 50° <input type="checkbox"/> UGR<19 asim.	-110 110V
	120	Track UGR 32W 4000K CRI80			
	111	Track UGR 17W 3000K CRI80			
	121	Track UGR 17W 4000K CRI80			
	1	White			
	2	Black			

## VIA TRACK

### 570mm

Option	Color T°	CRI	Difusor	Power	Lumen Output	Beam Angle
590	3000K	80	Opal / Microprisma	15W	1392lm / 1133lm	110° / 90°
570		80	Opal / Microprisma	25W	2506m / 2039m	110° / 90°
680	4000K	80	Opal / Microprisma	15W	1434lm / 1167lm	110° / 90°
660		80	Opal / Microprisma	25W	2581lm / 2100lm	110° / 90°

### 850mm

560	3000K	80	Opal / Microprisma	20W	2131lm / 1735lm	110° / 90°
540		80	Opal / Microprisma	38W	3809lm / 3121lm	110° / 90°
650	4000K	80	Opal / Microprisma	20W	2195lm / 1787lm	110° / 90°
630		80	Opal / Microprisma	39W	3923lm / 3214lm	110° / 90°

### 1130mm

530	3000K	80	Opal / Microprisma	27W	2842lm / 2313lm	110° / 90°
510		80	Opal / Microprisma	51W	5112lm / 4161lm	110° / 90°
620	4000K	80	Opal / Microprisma	27W	2927lm / 2382lm	110° / 90°
600		80	Opal / Microprisma	51W	5265lm / 4286lm	110° / 90°
110	3000K	80	UGR<16 / UGR<19	32W	3989lm / 4104lm / 3739lm	50° / 80° / Asym
120	4000K	80	UGR<16 / UGR<19	32W	4109lm / 4227lm / 3851lm	50° / 80° / Asym





# How to install

## CÓMO INSTALARLO

### 3Phase track, 16 A

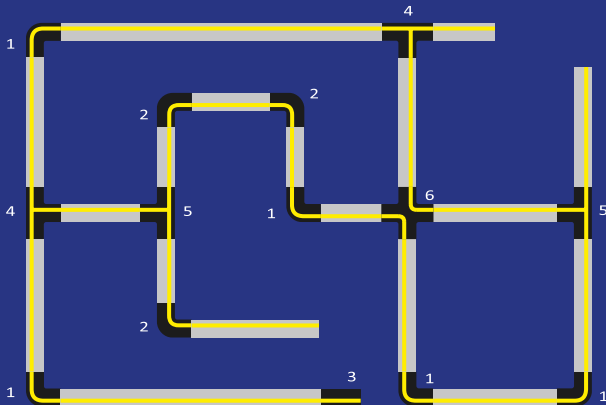

1 Outer "L" joint



2 Inner "L" joint



3 Outer live end



4 Outer "T"



5 Inner "T"



6 Cross joint

## Connection sketch Esquema de conexiones

### 1 Circuit

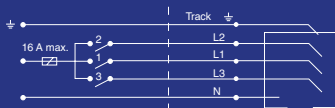

N-conductor  $i = 16$  A max

### 2 Circuit

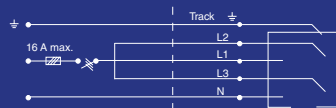

N-conductor  $i = 16$  A max

### 3 Circuit

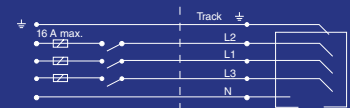

$L1 + L2 + L3$   $i = 16$  A max

## Recommended distance between fixing Distancia recomendada entre fijaciones

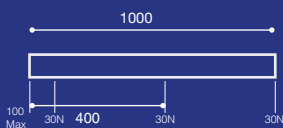

Max.Weight: 19,84 lb  
Peso máx.: 9 kg

Max. 3 projectors = 3,8 KVA  
Máx. 3 proyectores = 3,8 KVA

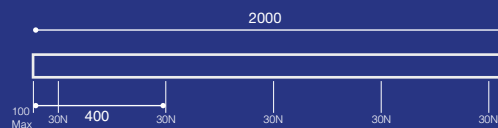

Max.Weight: 33,06 lb  
Peso máx.: 15 kg

Max. 5 projectors = 3,8 KVA  
Máx. 5 proyectores = 3,8 KVA

# 3Phase Track

Compatible with IVELA & GLOBAL



### Surface & Suspended 3 phase track

01990101	● White	1000 mm
01990102	● Black	1000 mm
01990201	● White	2000 mm
01990202	● Black	2000 mm

### Inner live end

	01990601	● White
	01990602	● Black

### Outer live end

	01990701	● White
	01990702	● Black

### Centre feed

	01993301	● White
	01993302	● Black

### Inner "L" Joint

	01990501	● White
	01990502	● Black

### Outer "L" Joint

	01990401	● White
	01990402	● Black

### Outer "T"

	01990901	● White
	01990902	● Black

### Inner "T"

	01991601	● White
	01991602	● Black

### Ceiling kit 1 piece

	01991201	● Aluminium
---	----------	-------------

### Cross Joint

	01991001	● White
	01991002	● Black

### Intermediate Joint

	01990801	● White
	01990802	● Black

### End cap

	01991101	● White
	01991102	● Black

### Flexible "L"

	01993201	● White
	01993202	● Black

### Pendant Kit 2000

	01990301	● White
	01990302	● Black

### Base for surface

	01991301	● White
	01991302	● Black

### Adapter / track connector

	01997001	● White
	01997002	● Black



### Surface & Suspended Dali track

01990101D	● White	1000 mm
01990102D	● Black	1000 mm
01990201D	● White	2000 mm
01990202D	● Black	2000 mm

### Dali inner live end

	01993501D	● White
	01993502D	● Black

### Dali outer live end

	01993601D	● White
	01993602D	● Black

### Dali centre feed

	01993301D	● White
	01993302D	● Black

### Inner "L" Joint

	01990501D	● White
	01990502D	● Black

### Outer "L" Joint

	01990401D	● White
	01990402D	● Black

### Ceiling kit 1 piece

	01991201D	● White
	01991202D	● Black

### Intermediate Joint

	01990801D	● White
	01990802D	● Black

### End cap

	01991101D	● White
	01991102D	● Black

### Flexible "L"

	01993201D	● White
	01993202D	● Black

### Pendant Kit 5000

	01990301D	● White
	01990302D	● Black

### Base for surface

	01991301D	● White
	01991302D	● Black

### Adapter / track connector

	01997001D	● White
	01997002D	● Black



### Recessed 3 phase track

01997101	● White	1000 mm
01997102	● Black	1000 mm
01997201	● White	2000 mm
01997202	● Black	2000 mm

### Inner live end

	01997401	● White
	01997402	● Black

### Outer live end

	01997301	● White
	01997302	● Black

### Centre feed

	01997801	● White
	01997802	● Black

### Intermediate Joint

	01997501	● White
	01997502	● Black

### End cap

	01997701	● White
	01997702	● Black

### Ceiling Kit 1piece

	01997601	● Aluminium
---	----------	-------------

### Adapter / track connector

	01997001	● White
	01997002	● Black



Thanks to EMMME Studio | Photo by Lupe Clemente



Track Lights

1247



D O W N L I G H T S

The KOPE downlight is the perfect solution for spaces with sloped ceilings or where precise light orientation is required. Its minimalist design makes it ideal for discreet integration into any environment. This versatile and compact downlight can be tilted and recessed according to lighting needs, providing complete control over the direction of light and adding functionality and elegance to any space.

El downlight KOPE es la solución perfecta para espacios con techos inclinados o donde se requiere una orientación precisa de la luz. Su diseño minimalista lo hace ideal para integrarse discretamente en cualquier entorno. Este downlight versátil y de dimensiones reducidas se puede inclinar y retraer según las necesidades de iluminación, brindando un control total sobre la dirección de la luz y dotando de funcionalidad y elegancia cualquier tipo de espacio.





**KOPE**





**Kope 7W**

**Kope 13W**

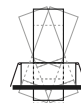
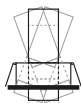

ø85

ø100

**FINISH**  
Acabado

● **Black**  
Negro

○ **White**  
Blanco

**COLOR TEMPERATURE**  
Temperatura de color

2700K CRI90

3000K CRI90

4000K CRI90

**BEAM ANGLE**  
Ángulo de apertura

20°

36°

**CONTROL SYSTEM**  
Sistema de control



CASAMBI



# Highlights



With two sizes and powers, Kope stands out for its ability to be adjustable, as well as for its “up-down” movement. Ideal for sloped ceilings where the light beam is to be kept vertical, or for light points where an adjustable or directional beam is desired.

Con dos tamaños y potencias, Kope destaca por la posibilidad de ser orientable, así como del movimiento “up down”. Ideal para techos inclinados en los que lo que se quiera mantener el haz de luz en vertical, o para puntos de luz donde se busque un haz inclinable u orientable.



## Consider the installation height in your project

Tenga en cuenta la altura de la instalación en su proyecto



## High CRI Alto IRC

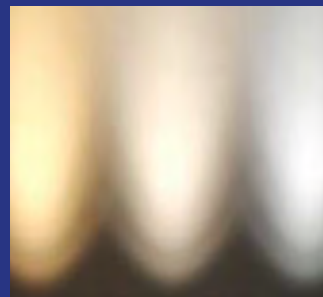

## Several color temperatures Varias temperaturas de color



## Possibility orientation, up down

Posibilidad orientación, subir y bajar



**Restaurant**



**Home**

## Beam Angle



**20°**

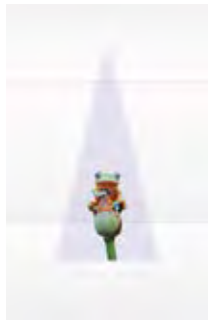

**36°**

# KOPE

incl. DIM 50.000hs L70 / B10 MacAdam 3 110V 50/60Hz 650°C

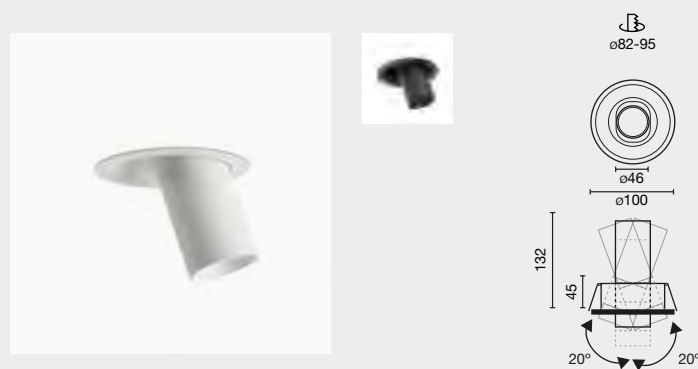
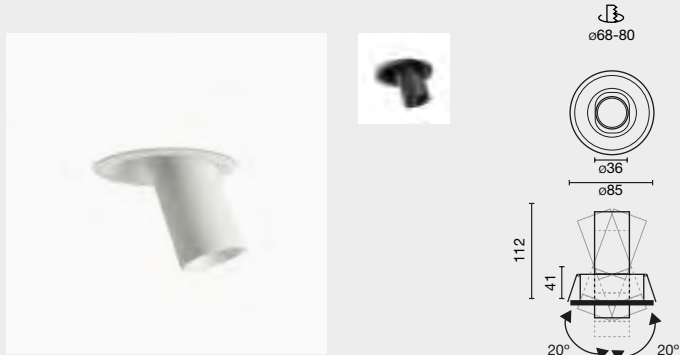

Family	Color T°	Beam Angle	Finish	Control System	Volt.
0225 Kope 7W	927 2700K CRI90	2 20°	1 White	ON/OFF	-110 110V
	930 3000K CRI90	4 36°	2 Black	D DALI	
	940 4000K CRI90			C TRIAC	
0226 Kope 13W	927 2700K CRI90	2 20°	1 White	ON/OFF	-110 110V
	930 3000K CRI90	4 36°	2 Black	W CASAMBI	
	940 4000K CRI90			D DALI	
				C TRIAC	

0354 927 6 1 W -110

Example 0022592721W-110 — Kope 7W 2700K CRI90 20° White Casambi 110V

Kope 7W

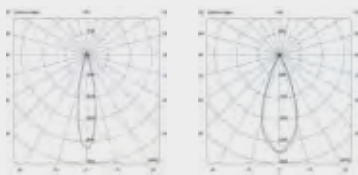

20°

36°

Kope 13W

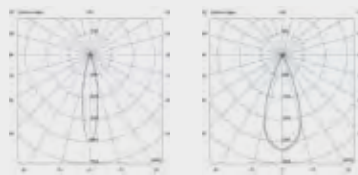

20°

36°

Option	Color T°	CRI	Power	Lumen Output	Beam Angle
927	2700K	90	7w	451/494	20°/36°
		90	13w	859/818	20°/36°
930	3000K	90	7w	465/495	20°/36°
		90	13w	886/837	20°/36°
940	4000K	90	7w	479/524	20°/36°
		90	13w	913/868	20°/36°









# KOBO

The KOBO downlight is a robust and reliable solution, with an IP67 rating, making it ideal for applications in hospitals and industries where resistance and durability are crucial. With two available beam angles, it can adapt to a wide range of lighting needs, from general illumination to specific tasks. Its solid design and features ensure high performance in demanding environments where light quality is essential.

El downlight KOBO es una solución robusta y confiable, con clasificación IP67 que lo hace ideal para aplicaciones en hospitales e industrias donde la resistencia y la durabilidad son fundamentales. Con dos ángulos de apertura disponibles, se adapta a un sinfín de necesidades de iluminación, desde iluminación general hasta tareas específicas. Su diseño sólido y sus prestaciones garantizan un alto rendimiento en entornos exigentes donde la calidad de la luz es esencial.



**Kobo**



ø235

**FINISH**  
Acabado

**White**  
Blanco

**COLOR TEMPERATURE**  
Temperatura de color

2700K CRI90

3000K CRI90

4000K CRI90

**BEAM ANGLE**  
Ángulo de apertura

60°

100°

**CONTROL SYSTEM**  
Sistema de control



CASAMBI





# Highlights

With two options for beam angles, a UGR below 19, and an IP67 protection rating, this downlight becomes the ideal choice for hospital environments. The Tunable White version provides the flexibility to offer circadian cycle lighting.

Con dos opciones de ángulos de apertura, un UGR inferior a 19 y un grado de protección IP67, este downlight se convierte en la opción ideal para entornos hospitalarios. La versión de Tunable White proporciona la flexibilidad de ofrecer iluminación de ciclo circadiano.



**IP65**  
IP65



**High CRI**  
Alto IRC



**Tunable white**

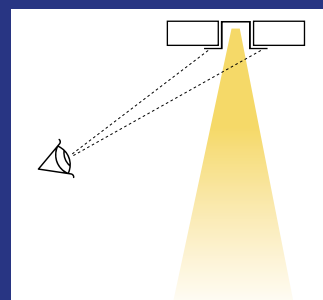

**UGR<19**



**Hospital**

## Beam Angle



**60°**



**100°**

# KOBO

incl. DIM 50.000hs L70 / B10 MacAdam 3 IP65 110V 50/60Hz 650°C



60°



100°

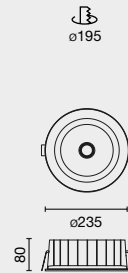

Family	Color T°	Beam Angle	Finish	Control System	Volt.
<b>0354</b> Kobo 27W	<b>927</b> 2700K CRI90	<b>6</b> 60°	<b>1</b> White	<b>W</b> CASAMBI	<b>-110</b> 110V
<b>0355</b> Kobo 15W	<b>930</b> 3000K CRI90	<b>9</b> 100°		<b>D</b> DALI	
	<b>940</b> 4000K CRI90			<b>C</b> TRIAC	
				<b>ON/OFF</b>	
<b>0354</b>	<b>927</b>	<b>6</b>	<b>1</b>	<b>W</b>	<b>-110</b>

Example **035492761W-110** — Kobo 27W 2700K CRI90 60° White Casambi 110V

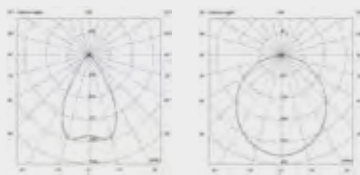

60°

100°

Option	Color T°	CRI	Power	Lumen Output	Beam Angle
927	2700K	90	15W	1506/1661lm	60° / 100°
			27W	2394/2640lm	
930	3000K	90	15W	1551/1711lm	60° / 100°
			27W	2468/2722lm	
940	4000K	90	15W	1598/1762lm	60° / 100°
			27W	2542/2804lm	





DEEP is a series of recessed light fixtures available in 3 sizes (S, M, L), two formats (round or square) and with or without frame. Its wide range of colour temperature, different optics and CRI options makes it a perfect option for commercial spaces, hotels, restaurants and retail. Its accessories enable better glare control and maximum visual comfort.

DEEP es una serie de luminarias empotradas disponible en 3 tamaños (S, M, L), dos formatos (redondo o cuadrado), y opción con marco y sin marco. Su amplia gama de temperatura de color, diversas ópticas y opciones de IRC la convierten en una opción perfecta para espacios comerciales, hoteles, restauración y retail. Sus accesorios permiten un mejor control del deslumbramiento, así como maximizar el confort visual.













# DEEP



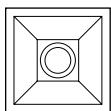
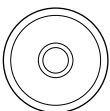
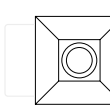
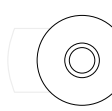

	TRIM Con marco		TRIMLESS Sin marco	
<b>S</b> 6 / 11W	 95x95	 ø93	 85x85	 ø83
<b>M</b> 12 / 18W	 115x115	 ø115	 103x103	 ø103
<b>L</b> 18 / 25 / 39W	 135x135	 ø135	 123x123	 ø123

**FINISH**  
Acabado

● **Black**  
Negro

○ **White**  
Blanco

**COLOR TEMPERATURE**  
Temperatura de color

2700K CRI90

3000K CRI90

4000K CRI90

FASHION

**BEAM ANGLE**  
Ángulo de apertura

15°

36°

60°

**ACCESSORIES**  
Accesorios



Honeycomb



Striped glass



Spread Glass

**CONTROL SYSTEM**  
Sistema de control



CASAMBI



# Highlights

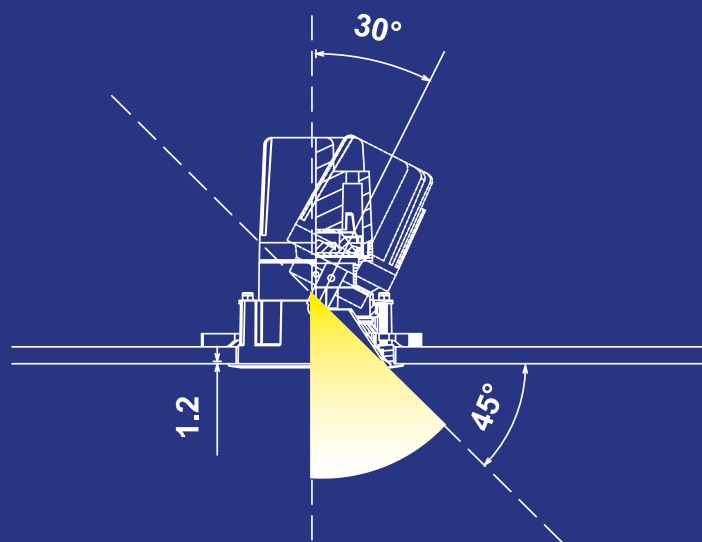

**Different sizes**  
Diversos tamaños



**High-quality materials**  
Materiales de alta calidad



**Adjustable**  
Orientable

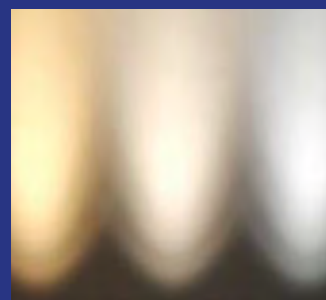

**Several color temperatures**  
Varias temperaturas de color

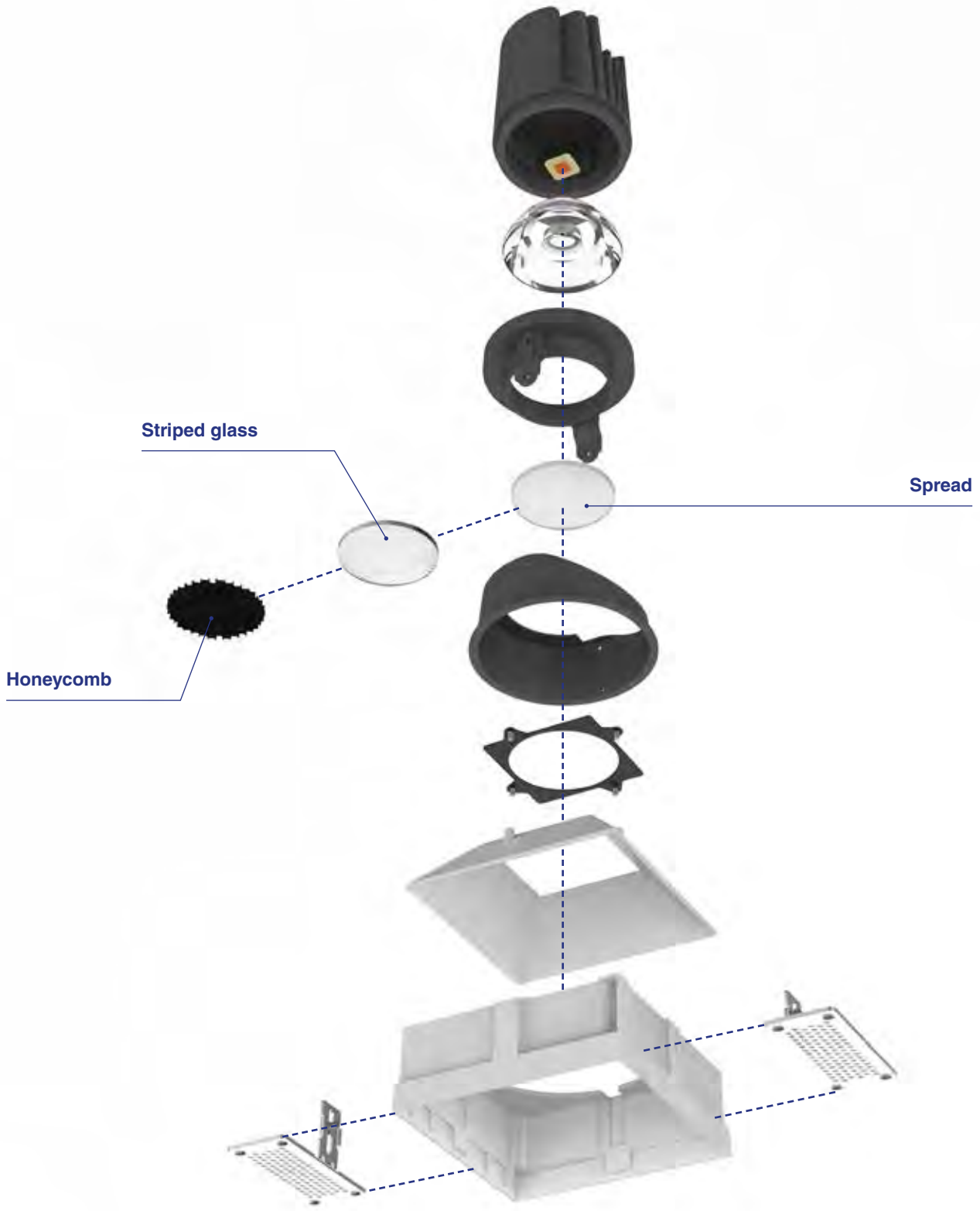





Honeycomb



Striped glass



Spread



Without accessory

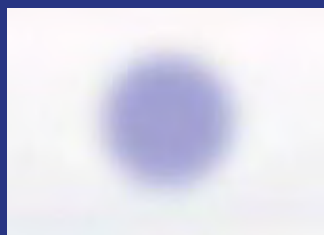

Spread Glass

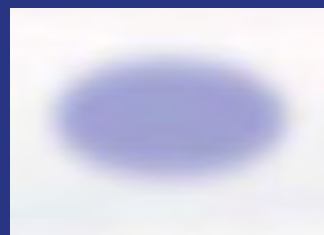

Striped Glass



Office



Restaurant



Retail

## Beam Angle



15°



36°



60°

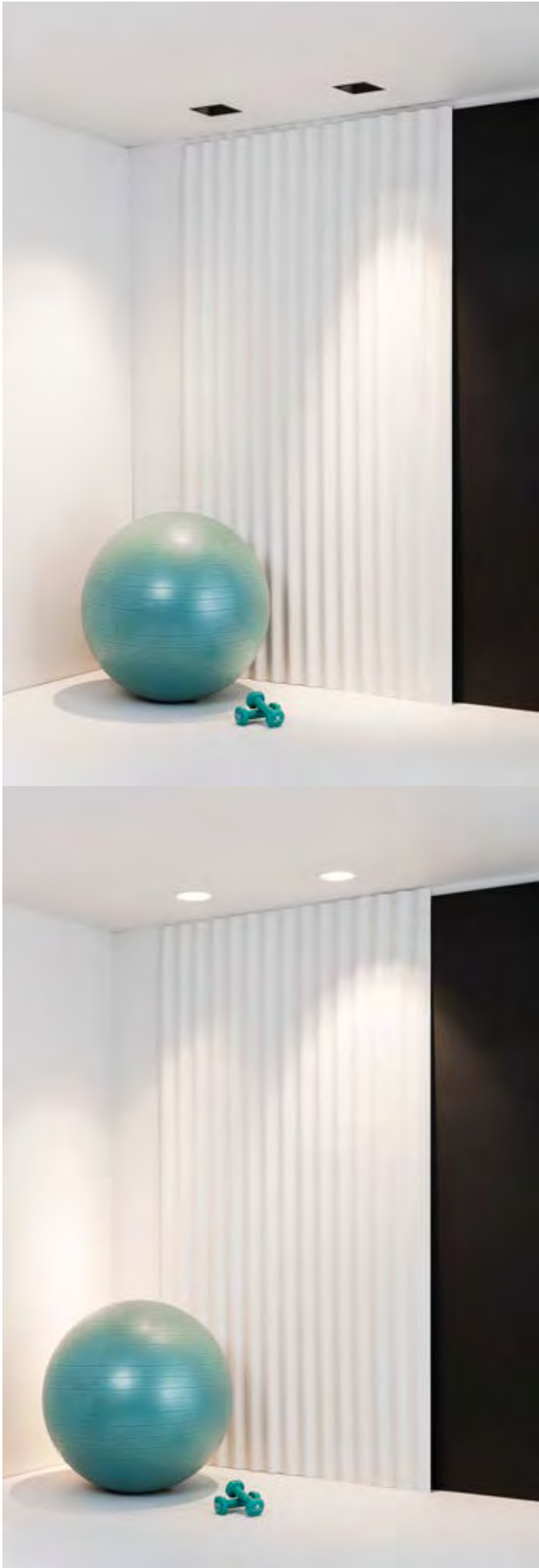

Thanks to Rodes Arquitectos | Photo by German Cabo



Need consulting  
for your project?  
¿Necesitas  
asesoramiento  
para tu proyecto?



Downlights

1275

1275

# DEEP S Round

no incl. DIM 355° 30° 50.000hs L90 / B10 MacAdam 2 IP23 6W 200mA 29V 11W 350mA 30V 650°C

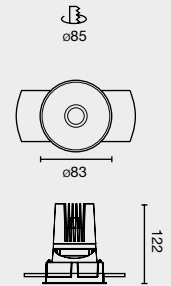
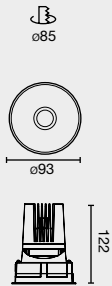

Family	Color T°	Beam Angle	Finish	Accessory
<b>30135</b> Deep S Round	<b>927</b> 2700K CRI90	<b>1</b> 15°	<b>1</b> White	No accessory
<b>30235</b> Deep S Round Trimless	<b>930</b> 3000K CRI90	<b>3</b> 36°	<b>2</b> Black	<b>H</b> Honeycomb
	<b>940</b> 4000K CRI90	<b>6</b> 60°		<b>S</b> Striped glass
				<b>D</b> Spread

**30135**      **827**      **1**      **1**      **H**

Example **3013592711H**— Deep 60 Round 2700K 15° White Honeycomb

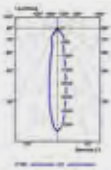

15°



36°



60°

Option	Color T°	CRI	Power	Lumen Output	Beam Angle
927	2700K	90	6W	291 / 352 / 287lm	15° / 36° / 60°
			11W	466 / 514 / 453lm	
930	3000K	90	6W	301 / 363 / 296lm	15° / 36° / 60°
			11W	481 / 530 / 467lm	
940	4000K	90	6W	310 / 374 / 305lm	15° / 36° / 60°
			11W	495 / 546 / 481lm	

Driver not included. See recommended drivers on page 428-429  
 Driver no incluido. Ver drivers recomendados en página 428-429



# DEEP S Square

no incl. DIM 355° 30° 50.000hs L90 / B10 MacAdam 2 IP23 6W 200mA 29V 11W 350mA 30V 650°C

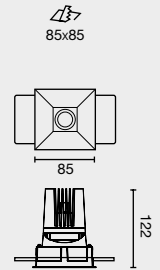
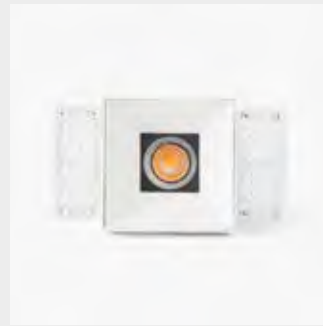
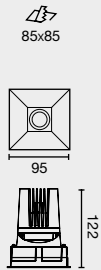

Family	Color T°	Beam Angle	Finish	Accessory
<b>30335</b> Deep S Square	<b>927</b> 2700K CRI90	<b>1</b> 15°	<b>1</b> White	No accessory
<b>30435</b> Deep S Square Trimless	<b>930</b> 3000K CRI90	<b>3</b> 36°	<b>2</b> Black	<b>H</b> Honeycomb
	<b>940</b> 4000K CRI90	<b>6</b> 60°		<b>S</b> Striped glass
				<b>D</b> Spread

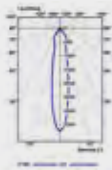

15°



36°

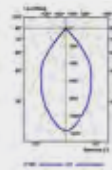

60°

Option	Color T°	CRI	Power	Lumen Output	Beam Angle
927	2700K	90	6W	291 / 352 / 287lm	15° / 36° / 60°
			11W	466 / 514 / 453lm	15° / 36° / 60°
930	3000K	90	6W	301 / 363 / 296lm	15° / 36° / 60°
			11W	481 / 530 / 467lm	15° / 36° / 60°
940	4000K	90	6W	310 / 374 / 305lm	15° / 36° / 60°
			11W	495 / 546 / 481lm	15° / 36° / 60°

**Driver not included.** See recommended drivers on page 428-429  
**Driver no incluido.** Ver drivers recomendados en página 428-429

# DEEP M Round

no incl. DIM 355° 30° 50.000hs L90 / B10 MacAdam 2 IP23 12W 350mA 34V 18W 500mA 36V 650°C

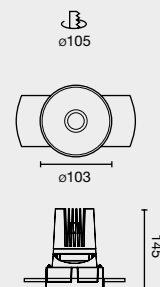
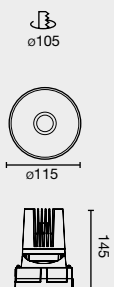

Family	Color T°	Beam Angle	Finish	Accessory
30550 Deep M Round	927 2700K CRI90	1 15°	1 White	No accessory
30650 Deep M Round Trimless	930 3000K CRI90	3 36°	2 Black	H Honeycomb
	940 4000K CRI90	6 60°		S Striped glass
				D Spread

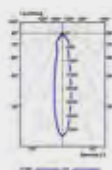

15°



36°



60°

Option	Color T°	CRI	Power	Lumen Output	Beam Angle
927	2700K	90	12W	1067 / 920 / 764lm	15° / 36° / 60°
			18W	1217 / 1290 / 1040lm	15° / 36° / 60°
930	3000K	90	12W	1110 / 949 / 788lm	15° / 36° / 60°
			18W	1255 / 1330 / 1073lm	15° / 36° / 60°
940	4000K	90	12W	1133 / 977 / 811lm	15° / 36° / 60°
			18W	1292 / 1369 / 1105lm	15° / 36° / 60°

Driver not included. See recommended drivers on page 428-429  
 Driver no incluido. Ver drivers recomendados en página 428-429

# DEEP M Square

no incl. DIM 355° 30° 50.000hs L90 / B10 MacAdam 2 IP23 12W 350mA 34V 18W 500mA 36V 650°C

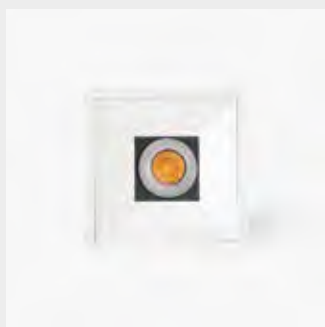

105x105



105x105

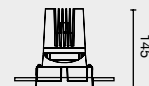
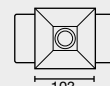

## Family

## Color T°

## Beam Angle

## Finish

## Accessory

<b>30750</b> Deep M Square	<b>927</b> 2700K CRI90	<b>1</b> 15°	<b>1</b> White	<ul style="list-style-type: none"> <li><input type="checkbox"/> No accessory</li> <li><input type="checkbox"/> <b>H</b> Honeycomb</li> <li><input type="checkbox"/> <b>S</b> Striped glass</li> <li><input type="checkbox"/> <b>D</b> Spread</li> </ul>
<b>30850</b> Deep M Square Trimless	<b>930</b> 3000K CRI90	<b>3</b> 36°	<b>2</b> Black	
	<b>940</b> 4000K CRI90	<b>6</b> 60°		

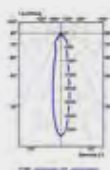

15°

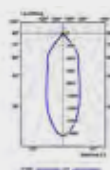

36°



60°

Option	Color T°	CRI	Power	Lumen Output	Beam Angle
927	2700K	90	12W	1067 / 920 / 764lm	15° / 36° / 60°
			18W	1217 / 1290 / 1040lm	15° / 36° / 60°
930	3000K	90	12W	1110 / 949 / 788lm	15° / 36° / 60°
			18W	1255 / 1330 / 1073lm	15° / 36° / 60°
940	4000K	90	12W	1133 / 977 / 811lm	15° / 36° / 60°
			18W	1292 / 1369 / 1105lm	15° / 36° / 60°

**Driver not included.** See recommended drivers on page 428-429  
**Driver no incluido.** Ver drivers recomendados en página 428-429

# DEEP L Round

no incl. DIM 355° 30° 50.000hs L90 / B10 MacAdam 2 IP23 18W 500mA 34V 25W 700mA 35V 39W 1050mA 37V 650°C

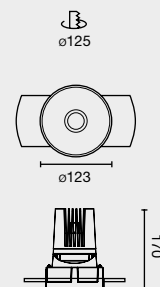

Family	Color T°	Beam Angle	Finish	Accessory
<b>30910</b> Deep L Round	<b>927</b> 2700K CRI90	<b>1</b> 15°	<b>1</b> White	No accessory
<b>31010</b> Deep L Round Trimless	<b>930</b> 3000K CRI90	<b>3</b> 36°	<b>2</b> Black	<b>H</b> Honeycomb
	<b>940</b> 4000K CRI90	<b>6</b> 60°		<b>S</b> Striped glass
	<b>941</b> Fashion CRI95			<b>D</b> Spread

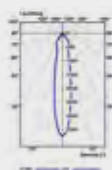

15°

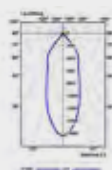

36°



60°

Option	Color T°	CRI	Power	Lumen Output	Beam Angle
927	2700K	90	18W	1420 / 1487 / 1248lm	15° / 36° / 60°
			25W	1923 / 1990 / 1668lm	15° / 36° / 60°
			39W	2551 / 2845 / 2361lm	15° / 36° / 60°
930	3000K	90	18W	1464 / 1534 / 1287lm	15° / 36° / 60°
			25W	1983 / 2052 / 1720lm	15° / 36° / 60°
			39W	2630 / 2934 / 2435lm	15° / 36° / 60°
940	4000K	90	18W	1507 / 1580 / 1325lm	15° / 36° / 60°
			25W	2042 / 2113 / 1771lm	15° / 36° / 60°
			39W	2708 / 3022 / 2508lm	15° / 36° / 60°
941	4000K	90	18W	1457 / 1528 / 1282lm	15° / 36° / 60°
			15W	1976 / 2044 / 1669lm	15° / 36° / 60°
			39W	2621 / 2923 / 2369lm	15° / 36° / 60°

Driver not included. See recommended drivers on page 428-429  
 Driver no incluido. Ver drivers recomendados en página 428-429

1280

# DEEP L Square

no incl. DIM 355° 30° 50.000hs L90 / B10 MacAdam 2 IP23 18W 500mA 34V 25W 700mA 35V 39W 1050mA 37V 650°C

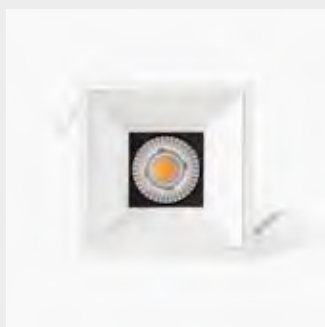

125x125



125x125

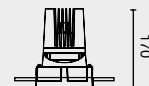
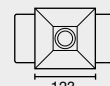

Family	Color T°	Beam Angle	Finish	Accessory
<b>31110</b> Deep L Square	<b>927</b> 2700K CRI90	<b>1</b> 15°	<b>1</b> White	No accessory
<b>31210</b> Deep L Square Trimless	<b>930</b> 3000K CRI90	<b>3</b> 36°	<b>2</b> Black	<b>H</b> Honeycomb
	<b>940</b> 4000K CRI90	<b>6</b> 60°		<b>S</b> Striped glass
	<b>941</b> Fashion CRI95			<b>D</b> Spread

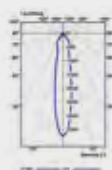

15°

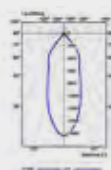

36°



60°

Option	Color T°	CRI	Power	Lumen Output	Beam Angle
927	2700K	90	18W	1420 / 1487 / 1248lm	15° / 36° / 60°
			25W	1923 / 1990 / 1668lm	15° / 36° / 60°
			39W	2551 / 2845 / 2361lm	15° / 36° / 60°
930	3000K	90	18W	1464 / 1534 / 1287lm	15° / 36° / 60°
			25W	1983 / 2052 / 1720lm	15° / 36° / 60°
			39W	2630 / 2934 / 2435lm	15° / 36° / 60°
940	4000K	90	18W	1507 / 1580 / 1325lm	15° / 36° / 60°
			25W	2042 / 2113 / 1771lm	15° / 36° / 60°
			39W	2708 / 3022 / 2508lm	15° / 36° / 60°
941	4000K	90	18W	1457 / 1528 / 1282lm	15° / 36° / 60°
			15W	1976 / 2044 / 1669lm	15° / 36° / 60°
			39W	2621 / 2923 / 2369lm	15° / 36° / 60°

Driver not included. See recommended drivers on page 428-429  
 Driver no incluido. Ver drivers recomendados en página 428-429



A collection of downlights with infinite options of sizes, formats, finishes and light angles. All this and much more in the palm of your hand.

Una colección de downlights con infinitas opciones de tamaños, formatos, acabados y ángulos de apertura. Todo esto y mucho más en la palma de tu mano.



# TROOP



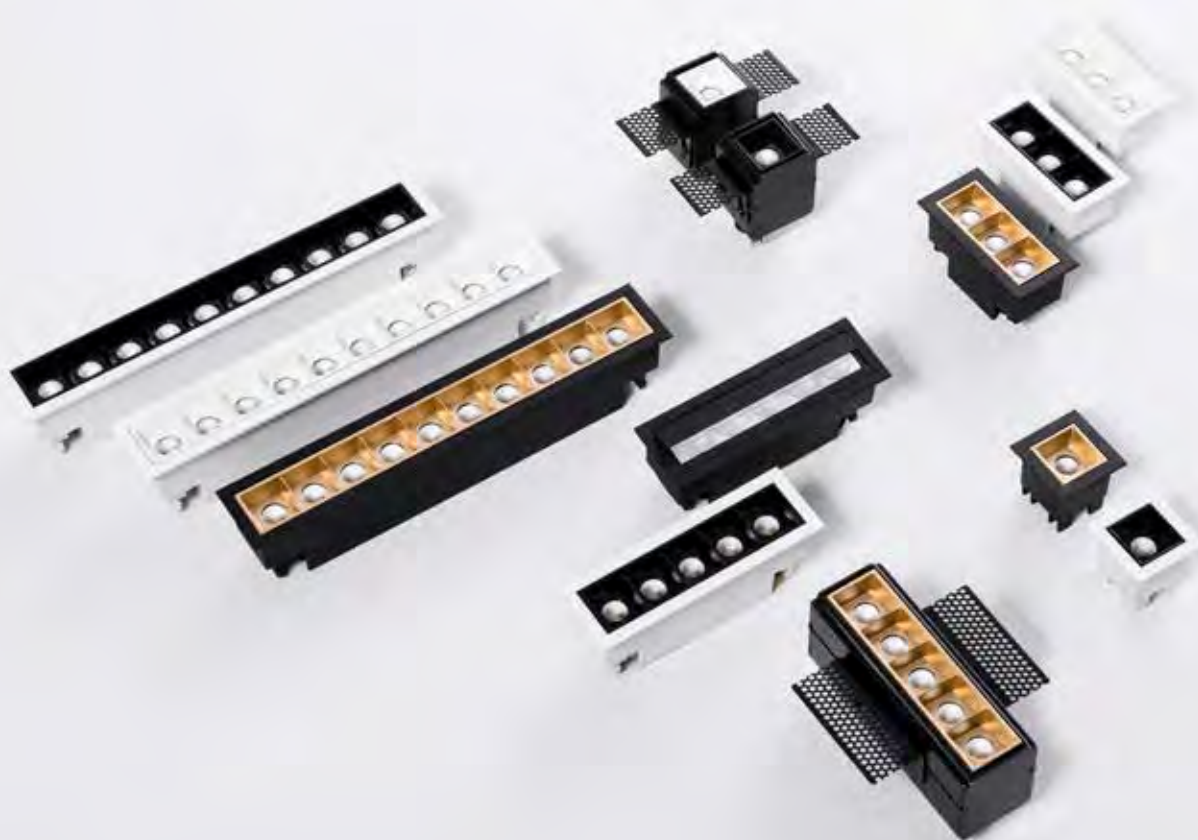

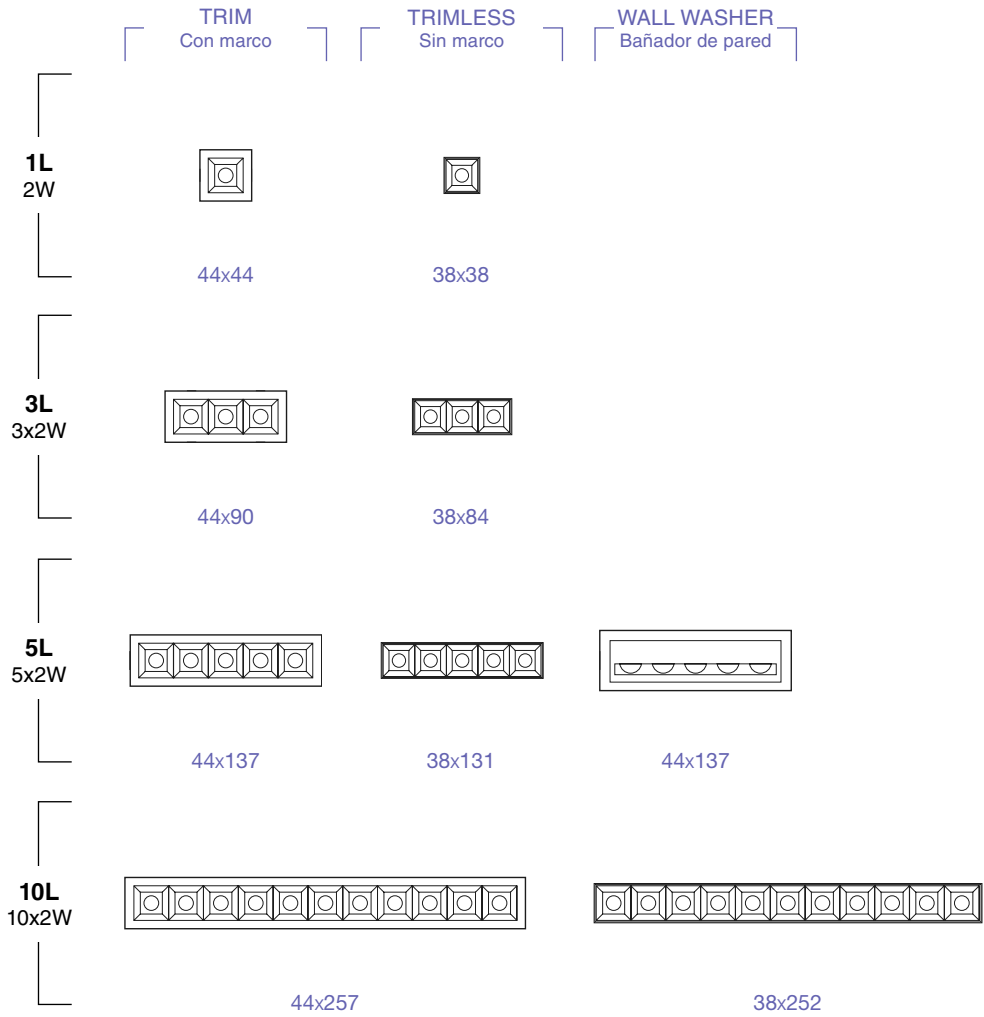

**FINISH**  
Acabado

● **Black+Black**  
Negro+Negro

◐ **Black+White**  
Negro+Blanco

○ **White+White**  
Blanco+Blanco

◑ **White+Black**  
Blanco+Negro

◐ **Black+Gold**  
Negro+Oro

◑ **White+Gold**  
Blanco+Oro

**COLOR TEMPERATURE**  
Temperatura de color

2700K CRI90

3000K CRI90

4000K CRI90

**BEAM ANGLE**  
Ángulo de apertura

15°

36°

48°

**CONTROL SYSTEM**  
Sistema de control



CASAMBI



# Highlights

## Anti-glare optics

Óptica antideslumbrante

## UGR

## Reflector with dark light technology

Reflector con tecnología dark light

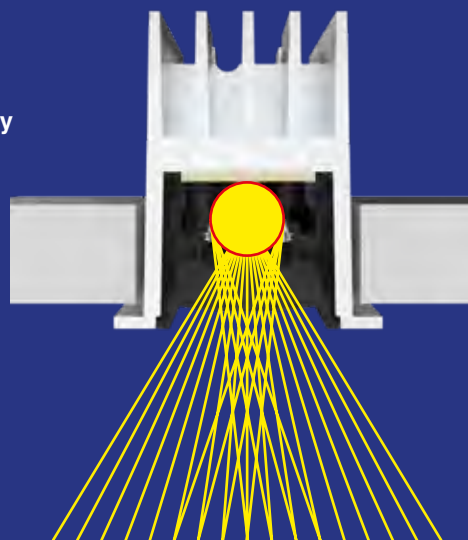

### Different sizes & finishes

Diversos tamaños y acabados



### Linear design with circular light effect

Diseño lineal con efecto lumínico circular



### Wall washer version

Versión bañador de pared

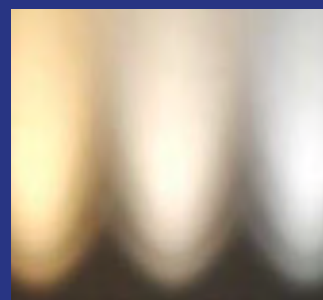

### Several color temperatures

Varias temperaturas de color





**Residential**



**Restaurant**

## Beam Angle



**15°**



**36°**



**48°**



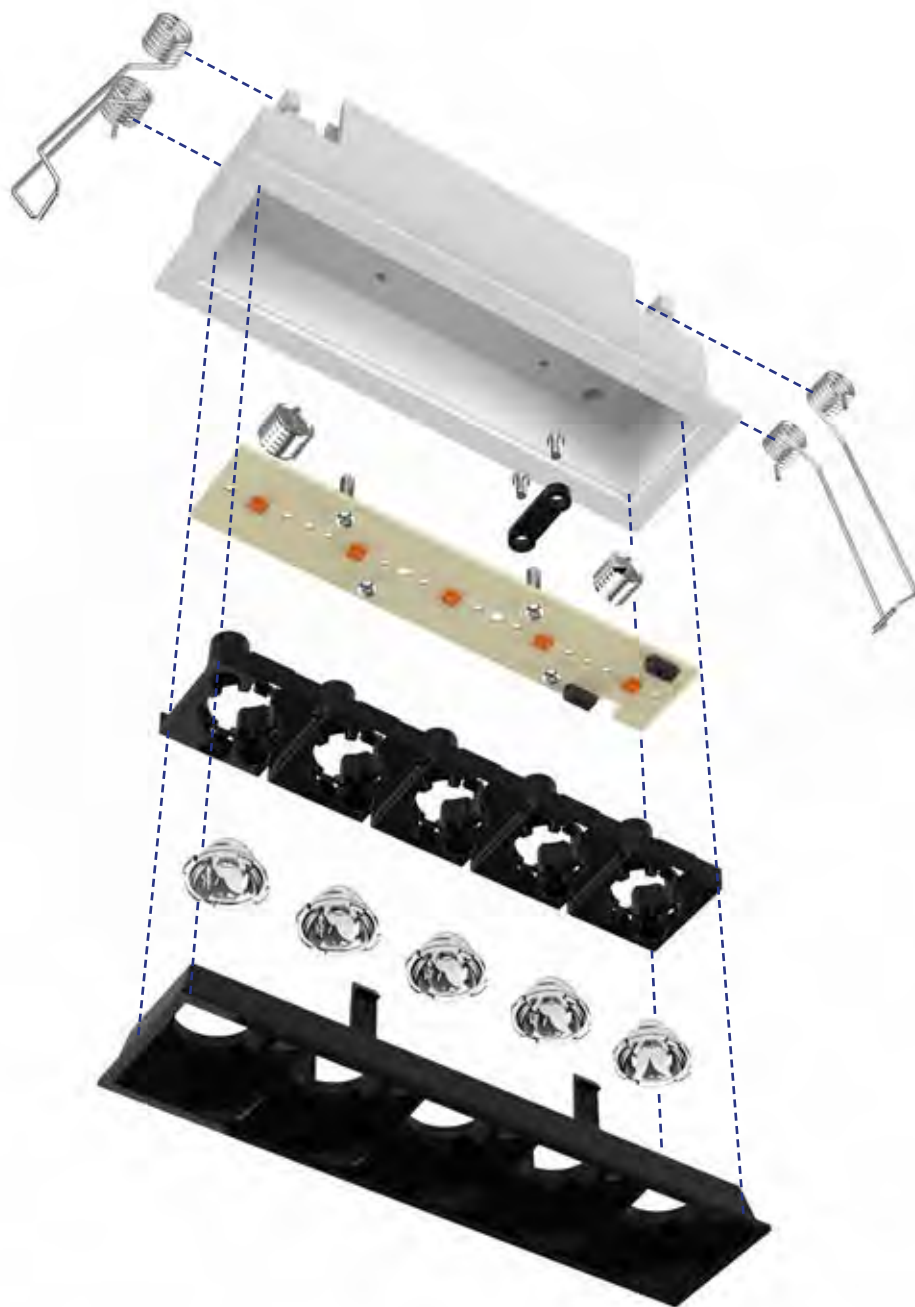

# TROOP 1L

no incl. DIM 50.000hs L70 / B10 MacAdam 3 700mA 2.85V 650°C UGR <16



Family	Color T°	Beam Angle	Trim	Anti-Glare
<b>43700</b> Troop Trim 2W	<b>927</b> 2700K CRI90	<b>1</b> 15°	<b>0</b> Trimless	<b>1</b> White
<b>43704</b> Troop Trimless 2W	<b>930</b> 3000K CRI90	<b>3</b> 36°	<b>1</b> White	<b>2</b> Black
	<b>940</b> 4000K CRI90	<b>4</b> 48°	<b>2</b> Black	<b>4</b> Gold

43700 927 1 1 1

Example **43700927111** — Troop Trim 2W 2700K 15° White White

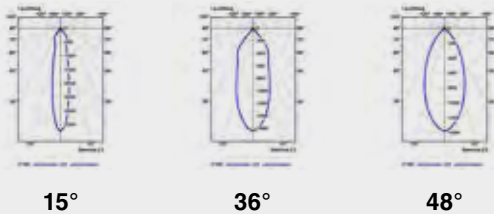

Option	Color T°	CRI	Power	Lumen Output	Beam Angle
927	2700K	90	2W	160lm / 163lm / 166lm	15° / 36° / 48°
930	3000K	90	2W	165lm / 168lm / 171lm	15° / 36° / 48°
940	4000K	90	2W	170lm / 173lm / 176lm	15° / 36° / 48°

Driver not included. See recommended drivers on page 428-429  
 Driver no incluido. Ver drivers recomendados en página 428-429

# TROOP 3L

no incl. DIM 50.000hs L70 / B10 MacAdam 3 700mA 8.61V 650°C UGR <16

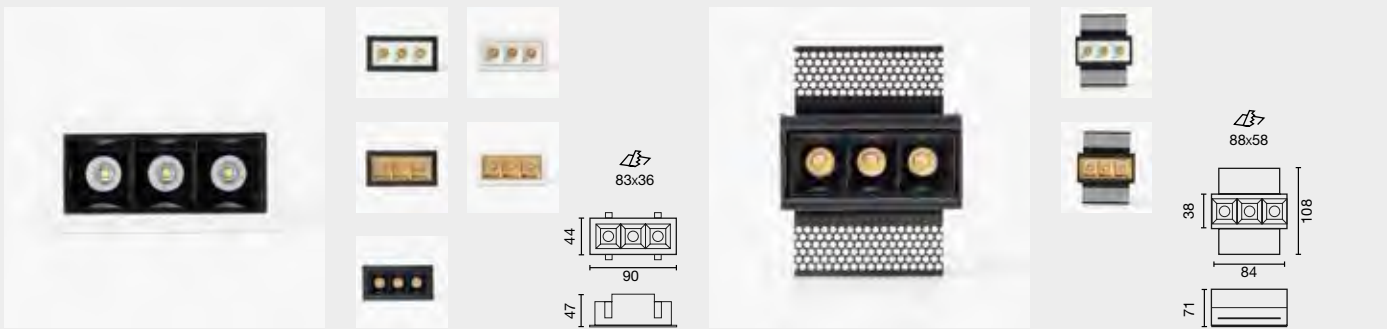

Family	Color T°	Beam Angle	Trim	Anti-Glare
<b>43701</b> Troop Trim 3x2W	<b>927</b> 2700K CRI90	<b>1</b> 15°	<b>0</b> Trimless	<b>1</b> White
<b>43705</b> Troop Trimless 3x2W	<b>930</b> 3000K CRI90	<b>3</b> 36°	<b>1</b> White	<b>2</b> Black
	<b>940</b> 4000K CRI90	<b>4</b> 48°	<b>2</b> Black	<b>4</b> Gold

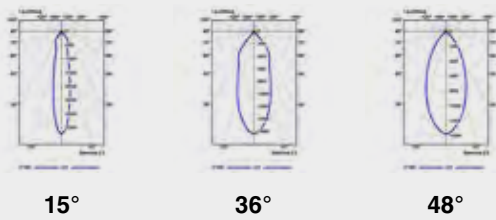

Option	Color T°	CRI	Power	Lumen Output	Beam Angle
927	2700K	90	3x2W	425lm / 650lm / 493lm	15° / 36° / 48°
930	3000K	90	3x2W	438lm / 670lm / 508lm	15° / 36° / 48°
940	4000K	90	3x2W	451lm / 690lm / 523lm	15° / 36° / 48°

**Driver not included.** See recommended drivers on page 428-429  
**Driver no incluido.** Ver drivers recomendados en página 428-429



# TROOP 5L

no incl. DIM 50.000hs L70 / B10 MacAdam 3 700mA 14.28V 650°C UGR <16



Family	Color T°	Beam Angle	Trim	Anti-Glare
<b>43702</b> Troop Trim 5x2W	<b>927</b> 2700K CRI90	<b>1</b> 15°	<b>0</b> Trimless	<b>1</b> White
<b>43706</b> Troop Trimless 5x2W	<b>930</b> 3000K CRI90	<b>3</b> 36°	<b>1</b> White	<b>2</b> Black
	<b>940</b> 4000K CRI90	<b>4</b> 48°	<b>2</b> Black	<b>4</b> Gold

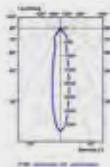

15°

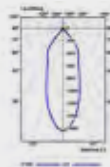

36°

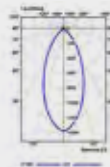

48°

Option	Color T°	CRI	Power	Lumen Output	Beam Angle
927	2700K	90	5x2W	672lm / 841lm / 828lm	15° / 36° / 48°
930	3000K	90	5x2W	692lm / 866lm / 853lm	15° / 36° / 48°
940	4000K	90	5x2W	712lm / 891lm / 878lm	15° / 36° / 48°

Driver not included. See recommended drivers on page 428-429  
 Driver no incluido. Ver drivers recomendados en página 428-429

# TROOP WALL WASHER

no incl. DIM 50.000hs L70 / B10 MacAdam 3 700mA 14.28V 650°C UGR <16

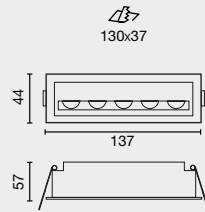

Family	Color T°	Beam Angle	Trim	Anti-Glare
43710 Troop Wall Washer 5x2W	927 2700K CRI90	0 Asymmetric	1 White	1 White
	930 3000K CRI90		2 Black	2 Black
	940 4000K CRI90			

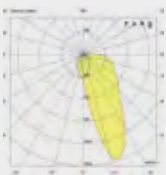

90°

Option	Color T°	CRI	Power	Lumen Output	Beam Angle
927	2700K	90	5x2W	519lm	90°
930	3000K	90	5x2W	535lm	90°
940	4000K	90	5x2W	551lm	90°

Driver not included. See recommended drivers on page 428-429  
 Driver no incluido. Ver drivers recomendados en página 428-429

# TROOP 10L

no incl. DIM 50.000hs L70 / B10 MacAdam 3 700mA 28.57V 650°C UGR <16

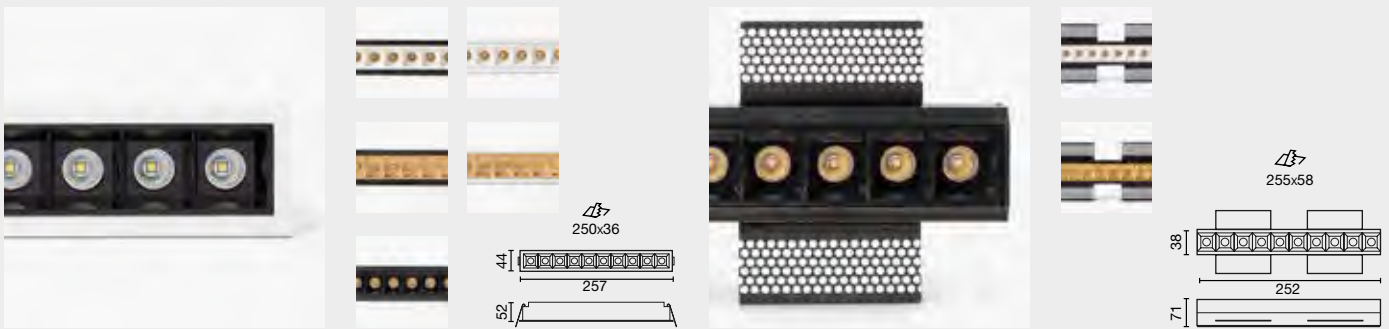

Family	Color T°	Beam Angle	Trim	Anti-Glare
<b>43703</b> Troop Trim 10x2W	<b>927</b> 2700K CRI90	<b>1</b> 15°	<b>0</b> Trimless	<b>1</b> White
<b>43707</b> Troop Trimless 10x2W	<b>930</b> 3000K CRI90	<b>3</b> 36°	<b>1</b> White	<b>2</b> Black
	<b>940</b> 4000K CRI90	<b>4</b> 48°	<b>2</b> Black	<b>4</b> Gold

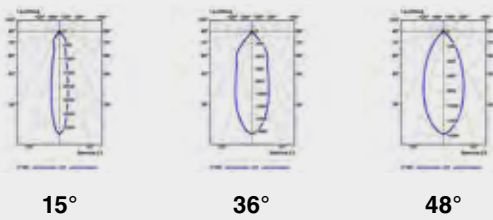

Option	Color T°	CRI	Power	Lumen Output	Beam Angle
927	2700K	90	10x2W	1379lm / 1681lm / 1755lm	15° / 36° / 48°
930	3000K	90	10x2W	1422lm / 1733lm / 1809lm	15° / 36° / 48°
940	4000K	90	10x2W	1465lm / 1785lm / 1863lm	15° / 36° / 48°

Driver not included. See recommended drivers on page 428-429  
 Driver no incluido. Ver drivers recomendados en página 428-429



**Need consulting  
for your project?**  
¿Necesitas  
asesoramiento  
para tu proyecto?





Squared luminaire available for 1,2 or 3 lamps. This family of luminaires is manufactured in different sizes and power so it is easy to find one that fits best to your lighting needs.









Colin es una serie de luminarias orientables de formato cuadrado/rectangular disponible para 1, 2 o 3 lámparas. La familia ofrece diferentes opciones de tamaños y potencias por lo que es fácil encontrar la que más se ajuste a vuestras necesidades de iluminación.





# COLIN

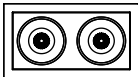
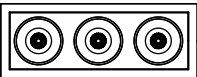

	TRIM Con marco			TRIMLESS Sin marco	
<b>Colin Nano</b> 7 / 13W					
	113x113	113x223		100x100	100x210
<b>Colin Mini</b> 18 / 25W					
	140x140	140x295	140x435		
<b>Colin</b> 24 / 36W					
	173x173	173x343	173x512		

**FINISH**  
Acabado

● **Black**  
Negro

○ **White**  
Blanco

● **Grey**  
Gris

**COLOR TEMPERATURE**  
Temperatura de color

2700K CRI82

3000K CRI85

4000K CRI85

2700K CRI95

3000K CRI95

4000K CRI95

MEAT

BREAD

FASHION

**BEAM ANGLE**  
Ángulo de apertura

20°

56°

**CONTROL SYSTEM**  
Sistema de control



CASAMBI



# Highlights

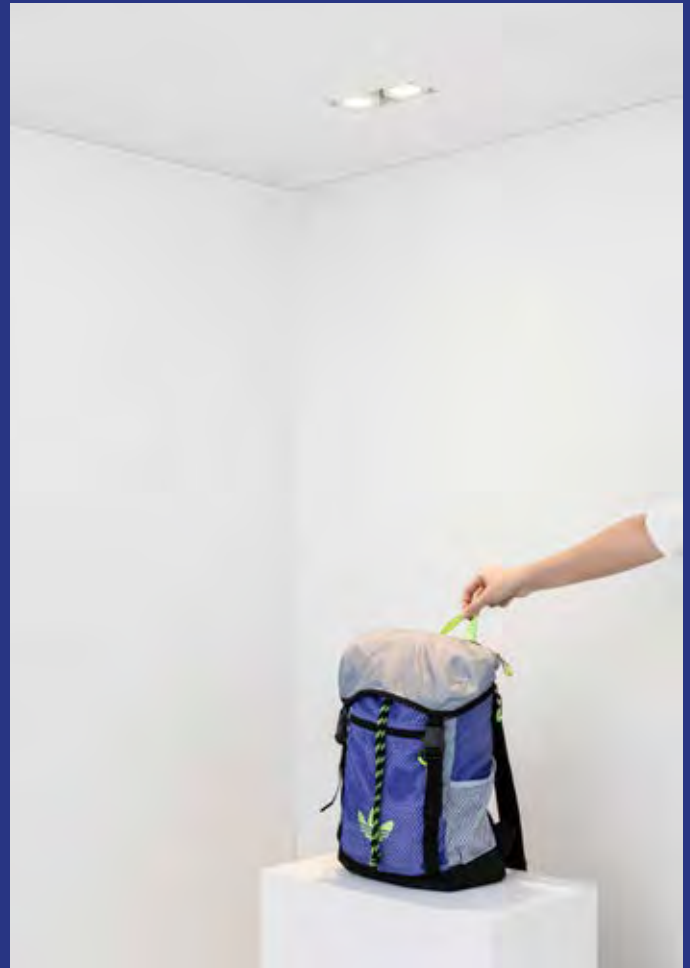

**Different sizes**  
Diversos tamaños



**Cardanic orientation**  
Orientación cardánica



**High CRI**  
Alto IRC

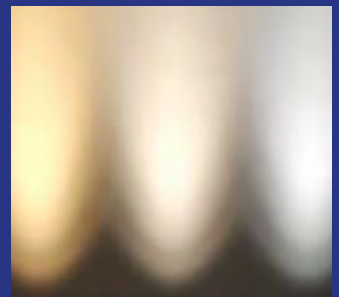

**Several color temperatures**  
Varias temperaturas de color



**Retail**

## Beam Angle



**20°**

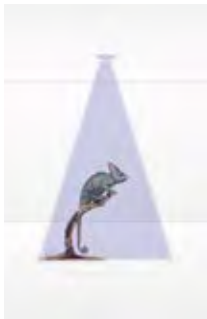

**56°**



# COLIN NANO 1L

no incl. DIM 20° 50.000hs L80 / B10 MacAdam 3 7W 13W 200mA 34V 350mA 35V 650°C

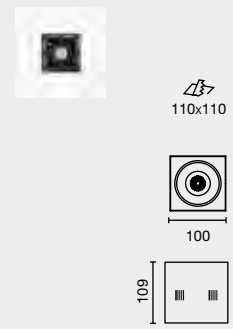
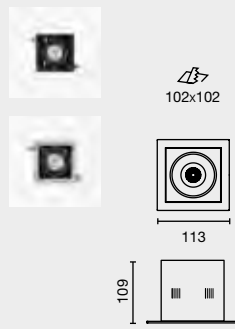

## Family

<b>035000</b>	Colin Nano 7 / 13W
<b>035100</b>	Colin Nano Trimless 7 / 13W

## Color T°

<b>10</b>	2700K CRI82 20°
<b>20</b>	2700K CRI82 56°
<b>30</b>	3000K CRI85 20°
<b>40</b>	3000K CRI85 56°
<b>50</b>	4000K CRI85 20°
<b>60</b>	4000K CRI85 56°

## Finish

<b>1</b>	White
<b>2</b>	Black
<b>3</b>	Grey (available only for trim)

**035000**

**10**

**1**

Example **035000101** — Colin Nano 7W 2700K CRI82 20° White

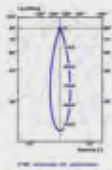

**20°**



**56°**

Color T°	CRI	Power	Lumen Output	Beam Angle
2700K	82	7W / 13W	691lm / 1120lm	20° / 56°
3000K	85	7W / 13W	712lm / 1155lm	20° / 56°
4000K	85	7W / 13W	733lm / 1190lm	20° / 56°

**Driver not included.** See recommended drivers on page 428-429  
**Driver no incluido.** Ver drivers recomendados en página 428-429

# COLIN NANO 2L

no incl. DIM 20° 50.000hs L80 / B10 MacAdam 3 2x7W 200mA 34V 2x13W 350mA 35V 650°C

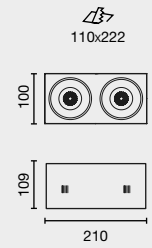
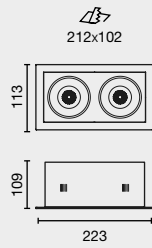

## Family

<b>035005</b>	Colin Nano 2L 14 / 26W
<b>035105</b>	Colin Nano 2L Trimless 14 / 26W

## Color T°

<b>00</b>	2700K CRI82 20°
<b>10</b>	2700K CRI82 56°
<b>20</b>	3000K CRI85 20°
<b>30</b>	3000K CRI85 56°
<b>40</b>	4000K CRI85 20°
<b>50</b>	4000K CRI85 56°

## Finish

<b>1</b>	White
<b>2</b>	Black
<b>3</b>	Grey (available only for trim)

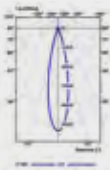

20°



56°

Color T°	CRI	Power	Lumen Output	Beam Angle
2700K	82	2x7W / 2x13W	2x691lm / 2x1120lm	20° / 56°
3000K	85	2x7W / 2x13W	2x712lm / 2x1155lm	20° / 56°
4000K	85	2x7W / 2x13W	2x733lm / 2x1190lm	20° / 56°

**Driver not included.** See recommended drivers on page 428-429  
**Driver no incluido.** Ver drivers recomendados en página 428-429

# COLIN MINI 1L

no incl. DIM 20° 50.000hs L80 / B10 MacAdam 3 18W 25W 500mA 33V 700mA 34V 650°C

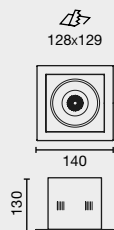

Family	Color T°	Finish
033008 Colin Mini 18 / 25W	30 2700K CRI82 20°	1 White
	40 2700K CRI82 56°	2 Black
	50 3000K CRI85 20°	3 Grey
	60 3000K CRI85 56°	
	70 4000K CRI85 20°	
	80 4000K CRI85 56°	
03300 CRI95	890 2700K CRI95 20°	1 White
	900 2700K CRI95 56°	2 Black
	910 3000K CRI95 20°	3 Grey
	920 3000K CRI95 56°	
	930 4000K CRI95 20°	
	940 4000K CRI95 56°	
03301 Food	011 BREAD 2500K CRI88 20°	1 White
	021 BREAD 2500K CRI88 56°	2 Black
	031 MEAT CRI82 20°	3 Grey
	041 MEAT CRI82 56°	
03301 Fashion	050 3100K CRI95 20°	1 White
	060 3100K CRI95 56°	2 Black
		3 Grey

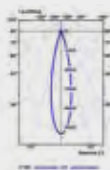

20°



56°

Color T°	CRI	Power	Lumen Output	Beam Angle
2700K	82	18W / 25W	1642lm / 2193lm	20° / 56°
	95		1361lm / 1882lm	
3000K	85	18W / 25W	1693lm / 2261lm	20° / 56°
	95		1403lm / 1878lm	
4000K	85	18W / 25W	1744lm / 2329lm	20° / 56°
	95		1445lm / 1934lm	
MEAT	82	18W / 25W	1335lm	20° / 56°
BREAD 2500K	88	18W / 25W	1801lm	20° / 56°
FASHION 3100K	95	18W / 25W	1841lm	20° / 56°

Driver not included. See recommended drivers on page 428-429  
 Driver no incluido. Ver drivers recomendados en página 428-429

# COLIN MINI 2L

no incl. DIM 20° 50.000hs L80 / B10 MacAdam 3 2x18W 500mA 33V 2x25W 700mA 34V 650°C

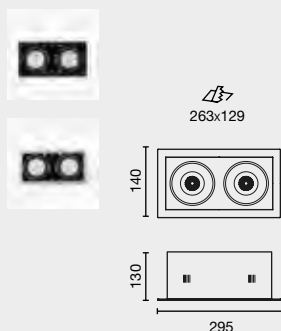

Family	Color T°	Finish	
03301 Colin Mini 2L 36 / 50W	090 2700K CRI82 20°	1 White	
	100 2700K CRI82 56°	2 Black	
	110 3000K CRI85 20°	3 Grey	
	120 3000K CRI85 56°		
	130 4000K CRI85 20°		
	140 4000K CRI85 56°		
	03301 CRI95	150 2700K CRI95 20°	1 White
		160 2700K CRI95 56°	2 Black
		170 3000K CRI95 20°	3 Grey
		180 3000K CRI95 56°	
190 4000K CRI95 20°			
200 4000K CRI95 56°			
03301 Food	271 BREAD 2500K CRI88 20°	1 White	
	281 BREAD 2500K CRI88 56°	2 Black	
	291 MEAT CRI82 20°	3 Grey	
	301 MEAT CRI82 56°		
03301 Fashion	330 3100K CRI95 20°	1 White	
	340 3100K CRI95 56°	2 Black	
		3 Grey	

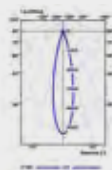

20°



56°

Color T°	CRI	Power	Lumen Output	Beam Angle
2700K	82	2x18W / 2x25W	2x1642lm / 2x2193lm	20° / 56°
	95		2x1361lm / 2x1882lm	
3000K	82	2x18W / 2x25W	2x1693lm / 2x2261lm	20° / 56°
	95		2x1403lm / 2x1878lm	
4000K	82	2x18W / 2x25W	2x1744lm / 2x2329lm	20° / 56°
	95		2x1445lm / 2x1934lm	
MEAT	82	2x18W / 2x25W	2x1335lm	20° / 56°
BREAD 2500K	88	2x18W / 2x25W	2x1801lm	20° / 56°
FASHION 3100K	95	2x18W / 2x25W	2x1841lm	20° / 56°

Driver not included. See recommended drivers on page 428-429  
 Driver no incluido. Ver drivers recomendados en página 428-429

# COLIN MINI 3L

no incl. DIM 20° 50.000hs L80 / B10 MacAdam 3 3x18W 3x25W 500mA 33V 700mA 34V 650°C



Family	Color T°	Finish
03301 Colin Mini 3L 54 / 75W	350 2700K CRI82 20°	1 White
	360 2700K CRI82 56°	2 Black
	370 3000K CRI85 20°	3 Grey
	380 3000K CRI85 56°	
	390 4000K CRI85 20°	
	400 4000K CRI85 56°	
03301 CRI95	410 2700K CRI95 20°	1 White
	420 2700K CRI95 56°	2 Black
	430 3000K CRI95 20°	3 Grey
	440 3000K CRI95 56°	
	450 4000K CRI95 20°	
	460 4000K CRI95 56°	
03301 Food	531 BREAD 2500K CRI88 20°	1 White
	541 BREAD 2500K CRI88 56°	2 Black
	551 MEAT CRI82 20°	3 Grey
	561 MEAT CRI82 56°	
03301 Fashion	590 3100K CRI95 20°	1 White
	600 3100K CRI95 56°	2 Black
		3 Grey

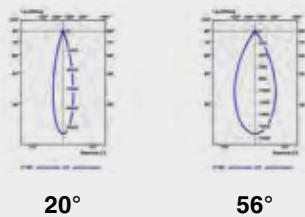

Color T°	CRI	Power	Lumen Output	Beam Angle
2700K	82	3x18W / 3x25W	3x1642lm / 3x2193lm	20° / 56°
	95		3x1361lm / 3x1882lm	
3000K	82	3x18W / 3x25W	3x1693lm / 3x2261lm	20° / 56°
	95		3x1403lm / 3x1878lm	
4000K	82	3x18W / 3x25W	3x1744lm / 3x2329lm	20° / 56°
	95		3x1445lm / 3x1934lm	
MEAT	82	3x18W / 3x25W	3x1335lm	20° / 56°
BREAD 2500K	88	3x18W / 3x25W	3x1801lm	20° / 56°
FASHION 3100K	95	3x18W / 3x25W	3x1841lm	20° / 56°

Driver not included. See recommended drivers on page 428-429  
 Driver no incluido. Ver drivers recomendados en página 428-429



# COLIN 1L

no incl. DIM 20° 50.000hs L80 / B10 MacAdam 3 24W 36W 700mA 33V 1050mA 34V 650°C

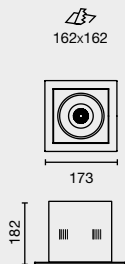
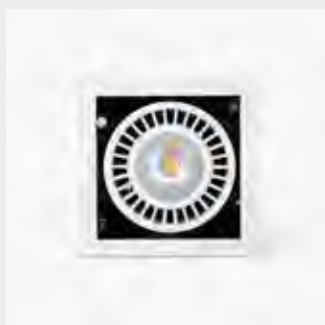

Family	Color T°	Finish
--------	----------	--------

03400 Colin 24 / 36W	850 2700K CRI82 20°	1 White
	860 2700K CRI82 56°	2 Black
	870 3000K CRI85 20°	3 Grey
	880 3000K CRI85 56°	
	890 4000K CRI85 20°	
	900 4000K CRI85 56°	

03400 CRI95	910 2700K CRI95 20°	1 White
	920 2700K CRI95 56°	2 Black
	930 3000K CRI95 20°	3 Grey
	940 3000K CRI95 56°	
	950 4000K CRI95 20°	
	960 4000K CRI95 56°	

03401 Food	031 BREAD 2500K CRI88 20°	1 White
	041 BREAD 2500K CRI88 56°	2 Black
	051 MEAT CRI82 20°	3 Grey
	061 MEAT CRI82 56°	

03401 Fashion	090 3100K CRI95 20°	1 White
	100 3100K CRI95 56°	2 Black
		3 Grey

0340040 Colin QR-111 LED G53 12V max.12W		1 White
		2 Black
		3 Grey

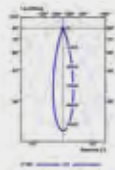

20°



56°

Color T°	CRI	Power	Lumen Output	Beam Angle
2700K	82	24 / 36W	2167lm / 3066lm	20° / 56°
	95		2072lm / 2930lm	
3000K	85	24 / 36W	2234lm / 3161lm	20° / 56°
	95		2136lm / 3021lm	
4000K	85	24 / 36W	2301lm / 3256lm	20° / 56°
	95		2200lm / 3112lm	
MEAT	82	24 / 36W	1406lm / 2023lm	20° / 56°
BREAD 2500K	88	24 / 36W	1912lm / 2750lm	20° / 56°
FASHION 3100K	95	24 / 36W	1977lm / 2844lm	20° / 56°

Driver not included. See recommended drivers on page 428-429  
 Driver no incluido. Ver drivers recomendados en página 428-429



Family	Color T°	Finish
03401 Colin 3L 48 / 72W	110 2700K CRI82 20°	1 White
	120 2700K CRI82 56°	2 Black
	130 3000K CRI85 20°	3 Grey
	140 3000K CRI85 56°	
	150 4000K CRI85 20°	
	160 4000K CRI85 56°	
03401 CRI95	170 2700K CRI95 20°	1 White
	180 2700K CRI95 56°	2 Black
	190 3000K CRI95 20°	3 Grey
	200 3000K CRI95 56°	
	210 4000K CRI95 20°	
	220 4000K CRI95 56°	
03401 Food	291 BREAD 2500K CRI88 20°	1 White
	301 BREAD 2500K CRI88 56°	2 Black
	311 MEAT CRI82 20°	3 Grey
	321 MEAT CRI82 56°	
03401 Fashion	350 3100K CRI95 20°	1 White
	360 3100K CRI95 56°	2 Black
		3 Grey
0340050 Colin 2L QR-111 LED G53 12V max.12W		1 White
		2 Black
		3 Grey

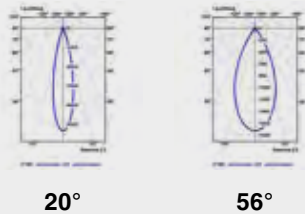

Color T°	CRI	Power	Lumen Output	Beam Angle
2700K	82	2x24 / 2x36W	2x2167lm / 2x3066lm	20° / 56°
	95		2x2072lm / 2x2930lm	
3000K	85	2x24 / 2x36W	2x2234lm / 2x3161lm	20° / 56°
	95		2x2136lm / 2x3021lm	
4000K	85	2x24 / 2x36W	2x2301lm / 2x3256lm	20° / 56°
	95		2x2200lm / 2x3112lm	
MEAT	82	2x24 / 2x36W	2x1406lm / 2x2023lm	20° / 56°
BREAD 2500K	88	2x24 / 2x36W	2x1912lm / 2x2750lm	20° / 56°
FASHION 3100K	95	2x24 / 2x36W	2x1977lm / 2x2844lm	20° / 56°

Driver not included. See recommended drivers on page 428-429  
 Driver no incluido. Ver drivers recomendados en página 428-429

# COLIN 3L

no incl. DIM 20° 50.000hs L80 / B10 MacAdam 3 3x24W 3x36W 700mA 33V 1050mA 34V 650°C



Family	Color T°	Finish	
03401 Colin 3L 72 / 108W	370 2700K CRI82 20°	1 White	
	380 2700K CRI82 56°	2 Black	
	390 3000K CRI85 20°	3 Grey	
	400 3000K CRI85 56°		
	410 4000K CRI85 20°		
	420 4000K CRI85 56°		
	03401 CRI95	430 2700K CRI95 20°	1 White
		440 2700K CRI95 56°	2 Black
		450 3000K CRI95 20°	3 Grey
		460 3000K CRI95 56°	
470 4000K CRI95 20°			
480 4000K CRI95 56°			
03401 Food	551 BREAD 2500K CRI88 20°	1 White	
	561 BREAD 2500K CRI88 56°	2 Black	
	571 MEAT CRI82 20°	3 Grey	
	581 MEAT CRI82 56°		
03401 Fashion	610 3100K CRI95 20°	1 White	
	620 3100K CRI95 56°	2 Black	
		3 Grey	
0340060 Colin 3L QR-111 LED G53 12V max.12W		1 White	
		2 Black	
		3 Grey	

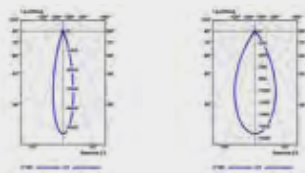

20°

56°

Color T°	CRI	Power	Lumen Output	Beam Angle
2700K	82	3x24 / 3x36W	3x2167lm / 3x3066lm	20° / 56°
	95		3x2072lm / 3x2930lm	
3000K	85	3x24 / 3x36W	3x2234lm / 3x3161lm	20° / 56°
	95		3x2136lm / 3x3021lm	
4000K	85	3x24 / 3x36W	3x2301lm / 3x3256lm	20° / 56°
	95		3x2200lm / 3x3112lm	
MEAT	82	3x24 / 3x36W	3x1406lm / 3x2023lm	20° / 56°
BREAD 2500K	88	3x24 / 3x36W	3x1912lm / 3x2750lm	20° / 56°
FASHION 3100K	95	3x24 / 3x36W	3x1977lm / 3x2844lm	20° / 56°

Driver not included. See recommended drivers on page 428-429  
 Driver no incluido. Ver drivers recomendados en página 428-429

Luminaire in a round adjustable format. This family of luminaires is manufactured in different sizes and powers so it is easy to find the one that best suits your lighting needs.

Luminaria de formato redondo orientable. Esta familia de luminarias se fabrica en diferentes tamaños y potencias por lo que es fácil encontrar la que más se ajuste a vuestras necesidades de iluminación.



# OPTIC







**Optic Mini**  
18 / 25W



ø140

**Optic**  
24 / 36W



ø165

**FINISH**  
Acabado

● **Black**  
Negro

○ **White**  
Blanco

● **Grey**  
Gris

**COLOR TEMPERATURE**  
Temperatura de color

2700K CRI82

3000K CRI85

4000K CRI85

2700K CRI95

3000K CRI95

4000K CRI95

MEAT

BREAD

FASHION

**BEAM ANGLE**  
Ángulo de apertura

20°

56°

**CONTROL SYSTEM**  
Sistema de control



CASAMBI



# Highlights

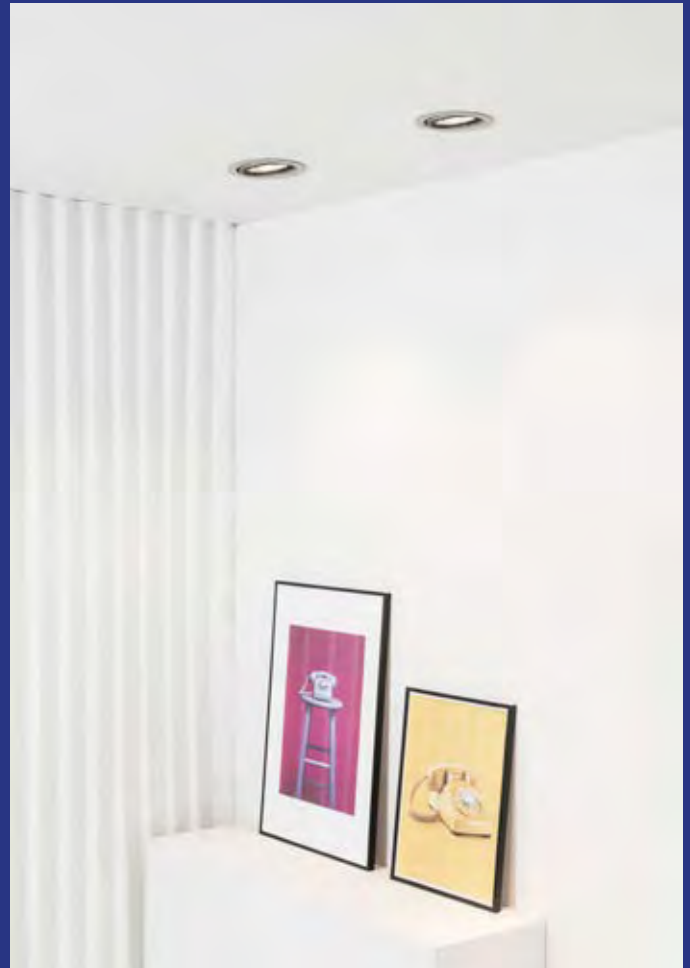

**Different sizes**  
Diversos tamaños



**Cardanic orientation**  
Orientación cardánica



**High CRI**  
Alto IRC

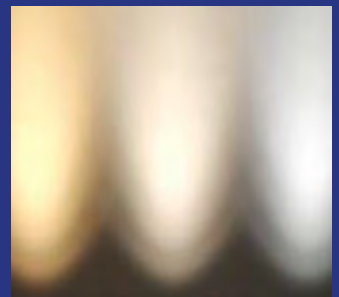

**Several color temperatures**  
Varias temperaturas de color

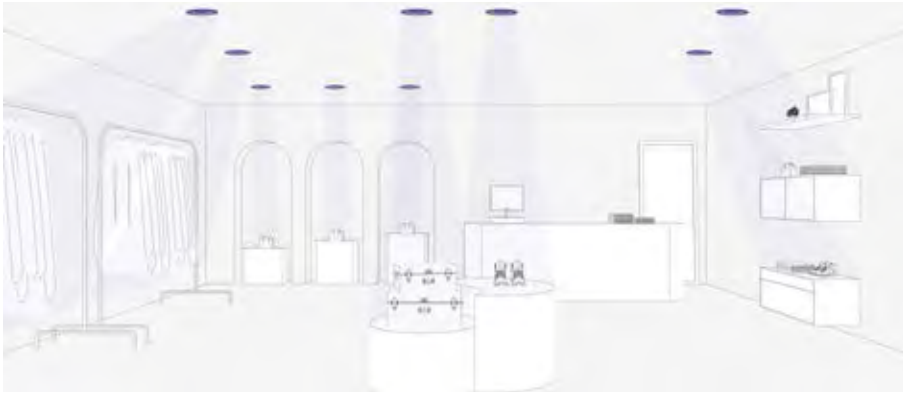

**Retail**

## Beam Angle



**20°**

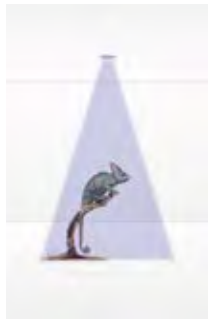

**56°**

# OPTIC MINI

no incl. DIM 20° 50.000hs L80 / B10 MacAdam 3 18W 25W 500mA 33V 700mA 34V 650°C

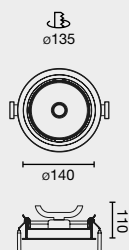
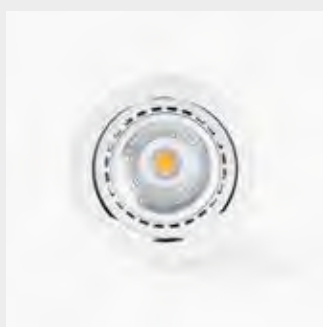

Family	Color T°	Finish
03250 Optic Mini 18 / 25W	300 2700K CRI82 20°	1 White
	310 2700K CRI82 56°	2 Black
	320 3000K CRI85 20°	3 Grey
	330 3000K CRI85 56°	
	340 4000K CRI85 20°	
	350 4000K CRI85 56°	
03250 CRI95	360 2700K CRI95 20°	1 White
	370 2700K CRI95 56°	2 Black
	380 3000K CRI95 20°	3 Grey
	390 3000K CRI95 56°	
	400 4000K CRI95 20°	
	410 4000K CRI95 56°	
03250 Food	481 BREAD 2500K CRI88 20°	1 White
	491 BREAD 2500K CRI88 56°	2 Black
	501 MEAT CRI82 20°	3 Grey
	511 MEAT CRI82 56°	
03250 Fashion	541 3100K CRI95 20°	1 White
	551 3100K CRI95 56°	2 Black 3 Grey

03250 300 1

Example **032503001** — Optic Mini 18W 2700K CRI82 20° White

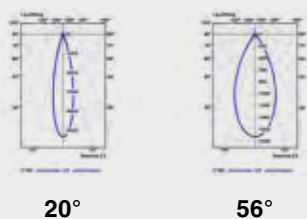

Color T°	CRI	Power	Lumen Output	Beam Angle
2700K	82	18W / 25W	1642lm / 2193lm	20° / 56°
	95		1361lm / 1882lm	
3000K	85	18W / 25W	1693lm / 2261lm	20° / 56°
	95		1403lm / 1878lm	
4000K	85	18W / 25W	1744lm / 2329lm	20° / 56°
	95		1445lm / 1934lm	
MEAT	82	18W / 25W	1335lm	20° / 56°
BREAD 2500K	88	18W / 25W	1801lm	20° / 56°
FASHION 3100K	95	18W / 25W	1841lm	20° / 56°

Driver not included. See recommended drivers on page 428-429  
 Driver no incluido. Ver drivers recomendados en página 428-429



# OPTIC

no incl. DIM 20° 50.000hs L80 / B10 MacAdam 3 24W 36W 700mA 33V 1050mA 34V 650°C



Family	Color T°	Finish
03200 Optic 24 / 36W	300 2700K CRI82 20°	1 White
	310 2700K CRI82 56°	2 Black
	320 3000K CRI85 20°	
	330 3000K CRI85 56°	
	340 4000K CRI85 20°	
	350 4000K CRI85 56°	
03200 CRI95	360 2700K CRI95 20°	1 White
	370 2700K CRI95 56°	2 Black
	380 3000K CRI95 20°	
	390 3000K CRI95 56°	
	400 4000K CRI95 20°	
	410 4000K CRI95 56°	
03200 Food	481 BREAD 2500K CRI88 20°	1 White
	491 BREAD 2500K CRI88 56°	2 Black
	501 MEAT CRI82 20°	
	511 MEAT CRI82 56°	
03200 Fashion	541 3100K CRI95 20°	1 White
	551 3100K CRI95 56°	2 Black

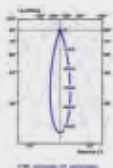

20°



56°

Color T°	CRI	Power	Lumen Output	Beam Angle
2700K	82	24 / 36W	2167lm / 3066lm	20° / 56°
	95		2072lm / 2930lm	
3000K	85	24 / 36W	2234lm / 3161lm	20° / 56°
	95		2136lm / 3021lm	
4000K	85	24 / 36W	2301lm / 3256lm	20° / 56°
	95		2200lm / 3112lm	
MEAT	82	24 / 36W	1406lm / 2023lm	20° / 56°
BREAD 2500K	88	24 / 36W	1912lm / 2750lm	20° / 56°
FASHION 3100K	95	24 / 36W	1977lm / 2844lm	20° / 56°

Driver not included. See recommended drivers on page 428-429  
 Driver no incluido. Ver drivers recomendados en página 428-429



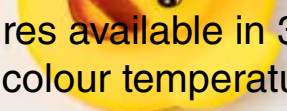

CROC is a family of recessed light fixtures available in 3 different sizes: 100 mm, 135 mm and 180 mm. Its different colour temperature options and its microprismatic optics for glare control make it a perfect option for work zones and spaces dedicated to healthcare. It has IP44 for humid zones and a low recess height.

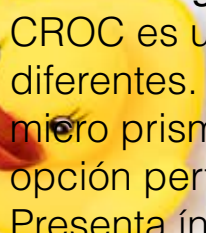

CROC es una familia de luminarias empotrables disponible en 3 tamaños diferentes. Sus diferentes opciones de temperatura de color y su óptica micro prismática para el control del deslumbramiento la convierten en una opción perfecta para zonas de trabajo y espacios dedicados a la salud. Presenta índice de protección 44 para zonas húmedas y una baja cota de empotramiento.



# CROC





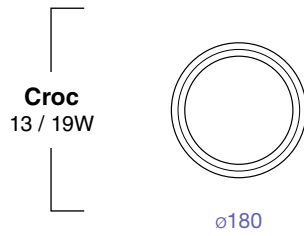
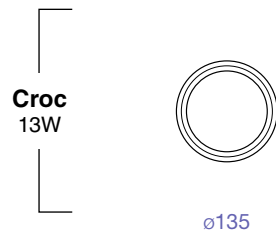
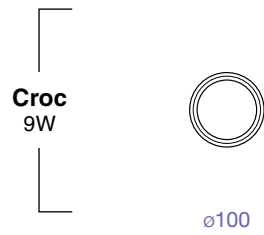

**FINISH**  
Acabado

**White**  
Blanco

**COLOR TEMPERATURE**  
Temperatura de color

2700K CRI90

3000K CRI90

4000K CRI90

**BEAM ANGLE**  
Ángulo de apertura



**CONTROL SYSTEM**  
Sistema de control



CASAMBI





# Highlights



**Different sizes**  
Diversos tamaños



**Tunable white**



**Micro-prismatic optics**  
Óptica micro prismática



**IP 54/44**

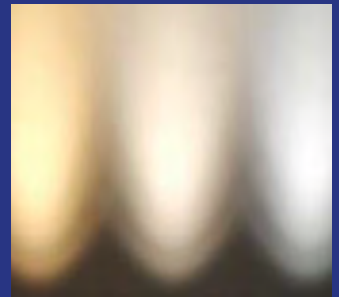

**Several color temperatures**  
Varias temperaturas de color



# CROC 9W

incl. DIM 50.000hs L70 / B10 MacAdam 3 IP 54/44 110V 50/60Hz 650°C

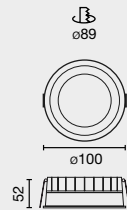

Family	Color T°	Beam Angle	Finish	Control System	Volt.
43780 CROC 9W	927 2700K CRI90	9 90°	1 White	W CASAMBI	-110 110V
	930 3000K CRI90			D DALI	
	940 4000K CRI90			C TRAC	
				ON/OFF	

43780 927 9 1 W -110

Example 4378092791W-110 — CROC 9W 2700K 90° White Casambi 110V



90°

Option	Color T°	CRI	Power	Lumen Output	Beam Angle
927	2700K	90	9W	753lm	90°
930	3000K	90	9W	776lm	90°
940	4000K	90	9W	799lm	90°

# CROC 13W

incl. DIM 50.000hs L70 / B10 MacAdam 3 IP 54/44 110V 50/60Hz 650°C UGR <19

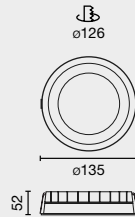

Family	Color T°	Beam Angle	Finish	Control System	Volt.
43781 Croc 13W	927 2700K CRI90	9 90°	1 White	W CASAMBI	-110 110V
	930 3000K CRI90			D DALI	
	940 4000K CRI90			C TRAC	
				ON/OFF	

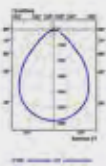

90°

Option	Color T°	CRI	Power	Lumen Output	Beam Angle
927	2700K	90	9W	1299lm	90°
930	3000K	90	9W	1339lm	90°
940	4000K	90	9W	1379lm	90°

# CROC 13/19W

incl. DIM 50.000hs L70 / B10 MacAdam 3 IP 54/44 110V 50/60Hz 650°C

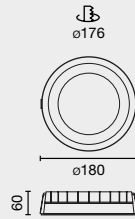

Family	Color T°	Beam Angle	Finish	Control System	Volt.																								
<table border="1"> <tr> <td>43782</td> <td>Croc 19W</td> </tr> <tr> <td>43783</td> <td>Croc 13W UGR&lt;19</td> </tr> </table>	43782	Croc 19W	43783	Croc 13W UGR<19	<table border="1"> <tr> <td>927</td> <td>2700K CRI90</td> </tr> <tr> <td>930</td> <td>3000K CRI90</td> </tr> <tr> <td>940</td> <td>4000K CRI90</td> </tr> </table>	927	2700K CRI90	930	3000K CRI90	940	4000K CRI90	<table border="1"> <tr> <td>9</td> <td>90°</td> </tr> </table>	9	90°	<table border="1"> <tr> <td>1</td> <td>White</td> </tr> </table>	1	White	<table border="1"> <tr> <td>W</td> <td>CASAMBI</td> </tr> <tr> <td>D</td> <td>DALI</td> </tr> <tr> <td>C</td> <td>TRIAC</td> </tr> <tr> <td></td> <td>ON/OFF</td> </tr> </table>	W	CASAMBI	D	DALI	C	TRIAC		ON/OFF	<table border="1"> <tr> <td>-110</td> <td>110V</td> </tr> </table>	-110	110V
43782	Croc 19W																												
43783	Croc 13W UGR<19																												
927	2700K CRI90																												
930	3000K CRI90																												
940	4000K CRI90																												
9	90°																												
1	White																												
W	CASAMBI																												
D	DALI																												
C	TRIAC																												
	ON/OFF																												
-110	110V																												

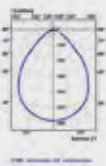

90°

Option	Color T°	CRI	Power	Lumen Output	Beam Angle
927	2700K	90	19W	2098lm	90°
930	3000K	90	19W	2163lm	90°
940	2700K	90	19W	2228lm	90°

UGR<19					
Option	Color T°	CRI	Power	Lumen Output	Beam Angle
927	2700K	90	13W	1616lm	90°
930	3000K	90	13W	1666lm	90°
940	2700K	90	13W	1716lm	90°





The BACKLIGHT panels are the perfect choice for efficiency and illuminating offices in an elegant way. These recessed panels provide soft and uniform lighting that promotes a comfortable and productive environment. Their discreet design easily integrates into the aesthetics of any office space. The uniform lighting they offer helps reduce glare and improve visual quality in the workplace.

Los paneles BACKLIGHT son la elección perfecta para iluminar oficinas de manera eficiente y elegante. Estos paneles empotrables proporcionan una iluminación suave y uniforme que favorece un ambiente confortable y productivo. Su diseño discreto se integra fácilmente en la estética de cualquier espacio de oficina. La iluminación uniforme que ofrece contribuye a reducir el deslumbramiento y a mejorar la calidad visual en el lugar de trabajo.

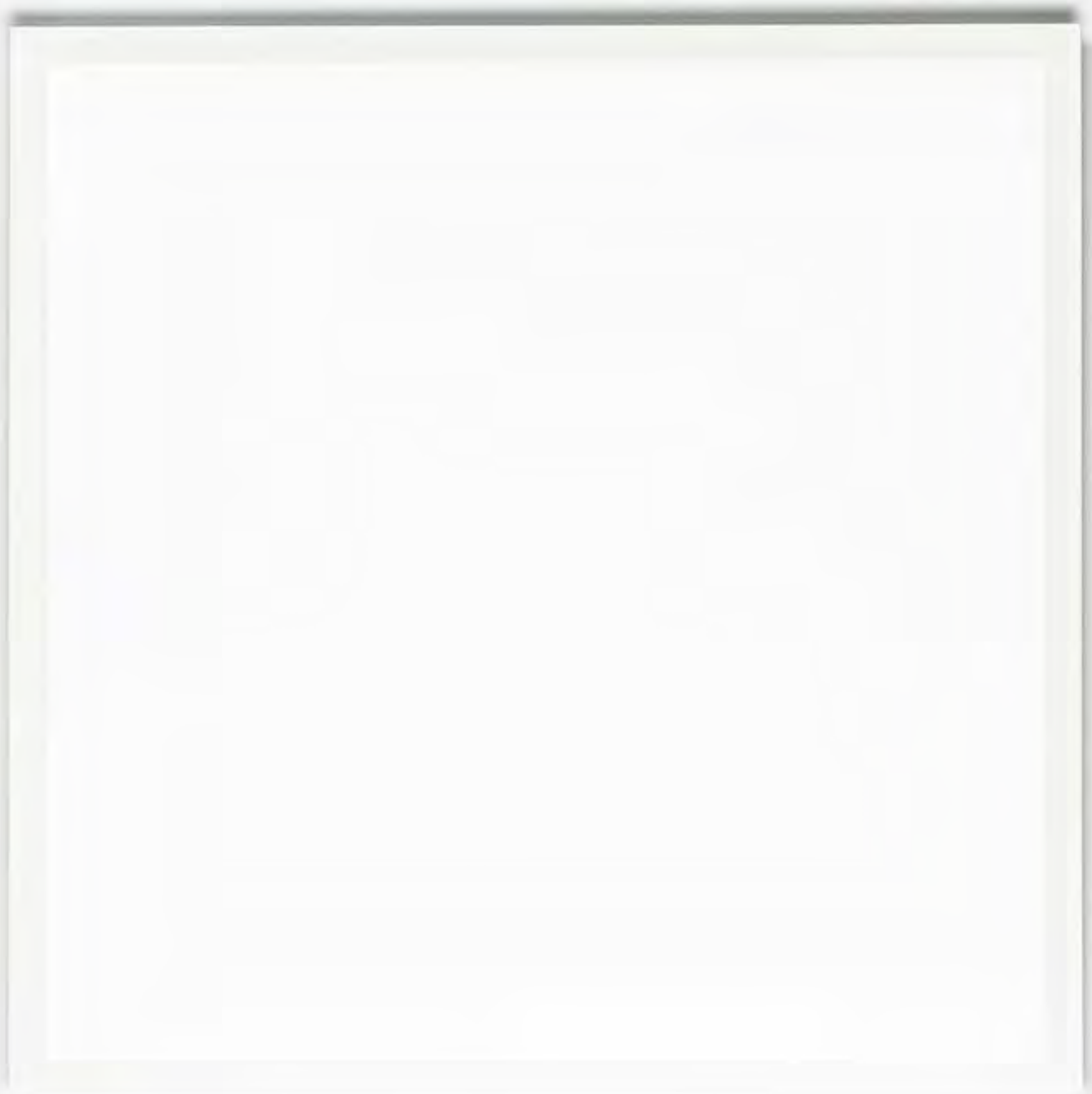

# BACK LIGHT





**Backlight**  
1195x295mm  
36W

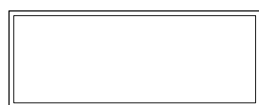

**Backlight**  
595mm  
36W



---

**FINISH**  
Acabado

**White**  
Blanco

---

**COLOR TEMPERATURE**  
Temperatura de color

3000K CRI80

4000K CRI80

---

**BEAM ANGLE**  
Ángulo de apertura

90°

---

**CONTROL SYSTEM**  
Sistema de control



CASAMBI





# Highlights

Thanks to its easy installation and high energy efficiency, this panel becomes the ideal option for providing general lighting in large spaces. With a UGR glare index below 19, it is a perfect choice for office environments.

Gracias a su sencilla instalación y su alta eficiencia energética, este panel se convierte en la opción ideal para proveer iluminación general en espacios amplios. Con un índice de deslumbramiento UGR inferior a 19, resulta una elección perfecta para entornos de oficina.

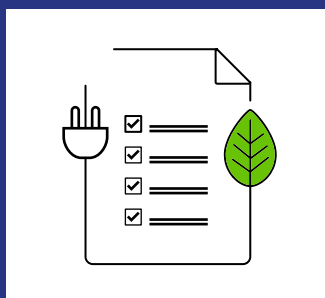

**High Efficiency**  
Alta eficiencia



**Easy Instalation modular ceiling**  
Techo modular de fácil instalación

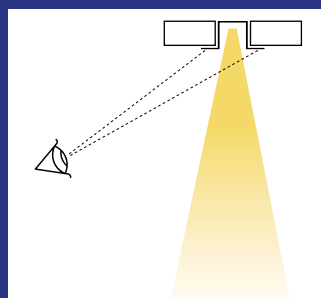

**UGR<19**



Office



Hospital

## Beam Angle



90°

# BACKLIGHT 36W

incl. DIM 50.000hs L80 / B10 MacAdam 3 110V 50/60Hz 650°C UGR <19

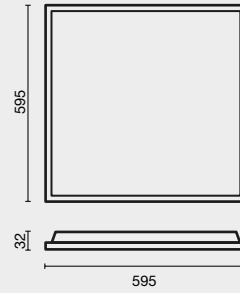
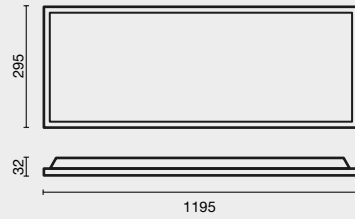

Family	Color T°	Beam Angle	Finish	Control System	Volt.
<b>0363</b> Backlight 1195x295 36W <b>0364</b> Backlight 595x595 36W	<b>830</b> 3000K CRI80 <b>840</b> 4000K CRI80	<b>9</b> 90°	<b>1</b> White	<b>W</b> CASAMBI <b>D</b> DALI <b>C</b> TRAC ON/OFF	<b>-110</b> 110V

**0363**                      **830**                      **9**                      **1**                      **D**                      **-110**

Example **036383091D-110** — Backlight 1195x295 36W 3000K CRI80 90° White Dali 110V

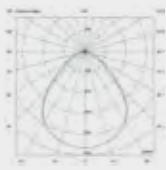

**90°**

Option	Color T°	CRI	Power	Lumen Output	Beam Angle
830	3000K	80	36W	4499lm	90°
840	4000K	80	36W	4638lm	90°









1336





# FOOST

## RECESSED

Recessed projector with an optical block designed to meet the highest requirements of accent lighting. This product offers an elegant and efficient solution to highlight specific spaces, providing exceptional quality accent lighting. Its recessed design makes it ideal for discreet integration into various environments, ensuring optimal performance in creating accentuated lighting effects. Proyector empotrable con un bloque óptico diseñado para satisfacer las más altas exigencias de iluminación de acento. Este producto ofrece una solución elegante y eficiente para resaltar espacios específicos, proporcionando una iluminación de calidad excepcional. Su diseño empotrable lo hace ideal para integrarse de manera discreta en diversos entornos, garantizando un rendimiento óptimo en la creación de efectos de iluminación acentuada.



**FOST Collection**



Track  
47



Pulldown  
181



Ceiling  
277



Surface  
267



Pendant  
323

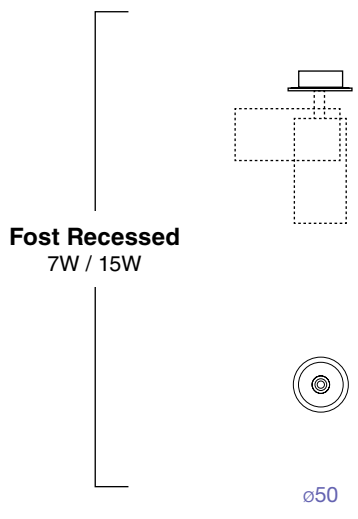

**FINISH**  
Acabado

- Black**  
Negro
- White**  
Blanco

**COLOR TEMPERATURE**  
Temperatura de color

2700K CRI90	3000K CRI90	4000K CRI90
2700K CRI97	3000K CRI97	4000K CRI97

**BEAM ANGLE**  
Ángulo de apertura



**ACCESSORIES**  
Accesorios

- White Ring
- Copper Ring

**CONTROL SYSTEM**  
Sistema de control



# Highlights



**Anti-glare**  
Anti deslumbramiento



**High CRI**  
Alto IRC

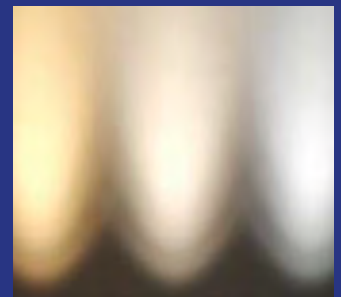

**Several color temperatures**  
Varias temperaturas de color



Need consulting  
for your project?  
¿Necesitas  
asesoramiento  
para tu proyecto?







**White Ring**



**Copper Ring**

# Accessories

	<b>White Ring</b>	<b>Copper Ring</b>
ø50	011600099	011600098



**Retail**



**Restaurant**

## Beam Angle



**12°**



**20°**

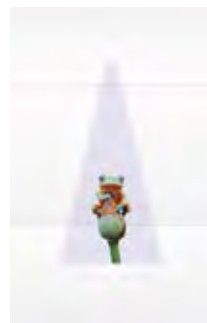

**35°**

# FOST RECESSED

incl. DIM 355° 90° 50.000hs L70 / B10 MacAdam 2&3 110V 50 / 60Hz 650°C

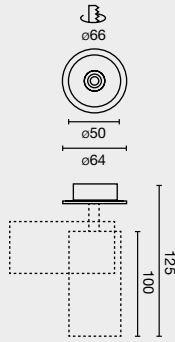

Family	Color T°	Beam Angle	Finish	Control System	Volt.
0124 Fost Recessed 7W	927 2700K CRI90	1 12°	1 White	ON/OFF	-110 110V
	930 3000K CRI90	2 20°	2 Black		
	940 4000K CRI90	3 35°			
	X27 2700K CRI97				
	X30 3000K CRI97				
	X40 4000K CRI97				
0125 Fost Recessed 15W	927 2700K CRI90	1 12°	1 White	ON/OFF C TRAC	-110 110V
	930 3000K CRI90	2 20°	2 Black		
	940 4000K CRI90	3 35°			
	X27 2700K CRI97				
	X30 3000K CRI97				
	X40 4000K CRI97				

0125 927 1 1 -110

Example 012592711-110 — Fost Recessed 15W 2700K CRI90 12° White 110V

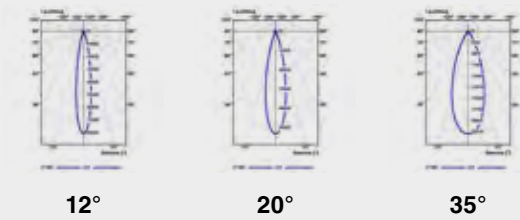

Option	Color T°	CRI	Power	Lumen Output	Beam Angle
927	2700K	90	7W	663lm / 674lm / 699lm	12°/20°/35°
x27		97	7W	596lm / 607lm / 629lm	12°/20°/35°
930	3000K	90	7W	683lm / 695lm / 721lm	12°/20°/35°
x30		97	7W	615lm / 626lm / 649lm	12°/20°/35°
940	4000K	90	7W	704lm / 716lm / 742lm	12°/20°/35°
x40		97	7W	633lm / 644lm / 668lm	12°/20°/35°
927	2700K	90	15W	1235lm / 1257lm / 1303lm	12° / 20° / 35°
X27		97	15W	1111lm / 1131lm / 1172lm	12° / 20° / 35°
930	3000K	90	15W	1273lm / 1295lm / 1343lm	12° / 20° / 35°
X30		97	15W	1146lm / 1166lm / 1209lm	12° / 20° / 35°
940	4000K	90	15W	1311lm / 1334lm / 1383lm	12° / 20° / 35°
X40		97	15W	1180lm / 1201lm / 1245lm	12° / 20° / 35°









# FOST

## PULLDOWN

Recessed light fixture designed to fulfill the downlight function with the possibility to be converted into a 100% functional projector thanks to its optical block extraction system, enabling it to meet the highest requirements of accent lighting. This characteristic grants FOST PULLDOWN a flexibility suitable for any multifunctional spaces that require its adaptation or modification from a fixed point.

Luminaria empotrada diseñada para cumplir la función de downlight y con posibilidad de convertirse en un proyector 100% funcional, gracias a su sistema de extracción del bloque óptico que le permite cumplir las máximas exigencias de una iluminación de acento. Esta característica le otorga a FOST PULLDOWN una flexibilidad idónea para espacios multifuncionales, que requieran una adaptación o modificación de éste desde un punto fijo.



### FOST Collection



Track  
47



Recessed  
171



Ceiling  
277



Surface  
267



Pendant  
323

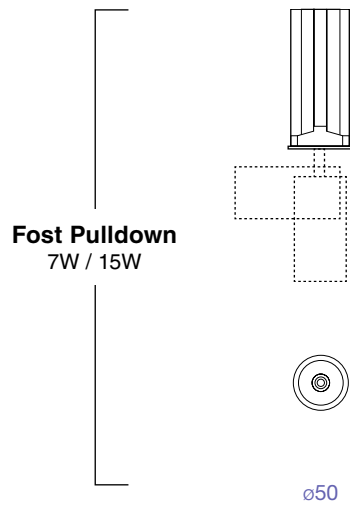

**FINISH**  
Acabado

● **Black**  
Negro

○ **White**  
Blanco

**COLOR TEMPERATURE**  
Temperatura de color

2700K CRI90	3000K CRI90	4000K CRI90
2700K CRI97	3000K CRI97	4000K CRI97

**BEAM ANGLE**  
Ángulo de apertura



**ACCESSORIES**  
Accesorios

White Ring

Copper Ring



**CONTROL SYSTEM**  
Sistema de control



# Highlights



**Its extraction system enables the block to be positioned at different heights without limiting creativity, creating a decorative geometric effect while lighting the space.**

Su sistema de extracción permite posicionar el bloque a diferentes alturas sin límites para la creatividad y generando un efecto geométrico decorativo a la vez que ilumina el espacio.

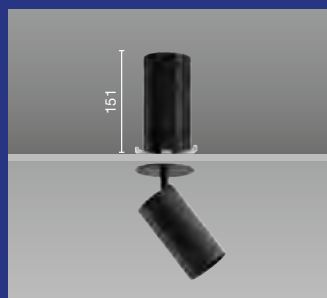

**Consider the installation height in your project**  
Tenga en cuenta la altura de la instalación en su proyecto



**High CRI**  
Alto IRC

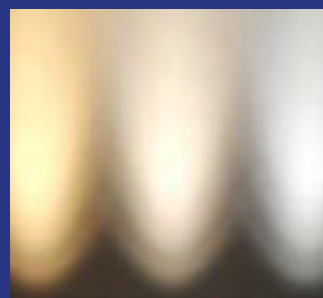

**Several color temperatures**  
Varias temperaturas de color







**White Ring**



**Copper Ring**

# Accessories

	<b>White Ring</b>	<b>Copper Ring</b>
ø50	011600099	011600098



**Retail**



**Restaurant**

## Beam Angle



**12°**



**20°**

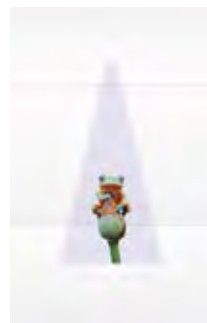

**35°**

# FOST PULLDOWN

incl. DIM 355° 90° 50.000hs L70 / B10 MacAdam 2&3 110V 50 / 60Hz 650°C

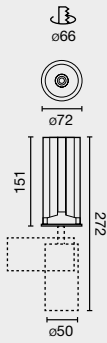

Family	Color T°	Beam Angle	Finish	Control System	Volt.
0123 Fost Pulldown 7W	927 2700K CRI90	1 12°	1 White	ON/OFF	-110 110V
	930 3000K CRI90	2 20°	2 Black		
	940 4000K CRI90	3 35°			
	X27 2700K CRI97				
	X30 3000K CRI97				
	X40 4000K CRI97				
0122 Fost Pulldown 15W	927 2700K CRI90	1 12°	1 White	ON/OFF C TRIAC	-110 110V
	930 3000K CRI90	2 20°	2 Black		
	940 4000K CRI90	3 35°			
	X27 2700K CRI97				
	X30 3000K CRI97				
	X40 4000K CRI97				

0122 927 1 1 -110  
 Example 012292711-110 — Fost Pulldown 15W 2700K CRI90 12° White 110V

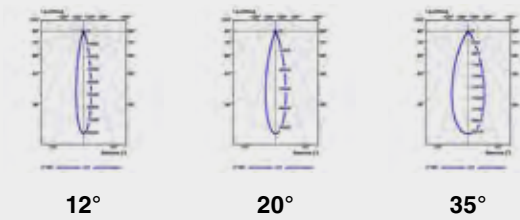

Option	Color T°	CRI	Power	Lumen Output	Beam Angle
927	2700K	90	7W	663lm / 674lm / 699lm	12°/20°/35°
x27		97	7W	596lm / 607lm / 629lm	12°/20°/35°
930	3000K	90	7W	683lm / 695lm / 721lm	12°/20°/35°
x30		97	7W	615lm / 626lm / 649lm	12°/20°/35°
940	4000K	90	7W	704lm / 716lm / 742lm	12°/20°/35°
x40		97	7W	633lm / 644lm / 668lm	12°/20°/35°
927	2700K	90	15W	1235lm / 1257lm / 1303lm	12° / 20° / 35°
X27		97	15W	1111lm / 1131lm / 1172lm	12° / 20° / 35°
930	3000K	90	15W	1273lm / 1295lm / 1343lm	12° / 20° / 35°
X30		97	15W	1146lm / 1166lm / 1209lm	12° / 20° / 35°
940	4000K	90	15W	1311lm / 1334lm / 1383lm	12° / 20° / 35°
X40		97	15W	1180lm / 1201lm / 1245lm	12° / 20° / 35°



Downlights

1355

Size does matter. UNO has a design that is small in dimension and a large capacity to create environments with light with minimum visual invasion, both in the space and on the recess surface.

El tamaño sí importa. UNO presenta un diseño de reducidas dimensiones y una gran capacidad de crear entornos con luz con la mínima invasión visual, tanto en el espacio como en la superficie de empotramiento.





**UNO**





**FINISH**  
Acabado

● **Black+Black**  
Negro+Negro

◐ **Black+White**  
Negro+Blanco

○ **White+White**  
Blanco+Blanco

◑ **White+Black**  
Blanco+Negro

◐ **Black+Gold**  
Negro+Oro

◑ **White+Gold**  
Blanco+Oro

**COLOR TEMPERATURE**  
Temperatura de color

2700K CRI90

3000K CRI90

**BEAM ANGLE**  
Ángulo de apertura

11°

24°

37°

**ACCESSORIES**  
Accesorios



Honeycomb

**CONTROL SYSTEM**  
Sistema de control



CASAMBI

# Highlights



**The size/flow ratio of its downlight and extractable projector versions makes it possible to fulfill the requirements needed for applications in hotels, restaurants and retail, as well as its domestic application.**

La relación tamaño-flujo de sus versiones downlight y proyector extraíble hacen posible que, además de su aplicación doméstica, cumpla con las exigencias requeridas para aplicaciones en hoteles, restaurantes y retail.

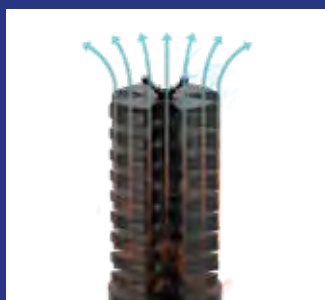

**Passive heat dissipation system**  
Sistema de disipación térmica pasiva



**Glare control**  
Control de deslumbramiento



**Removable downlight module**  
Módulo downlight extraíble a presión

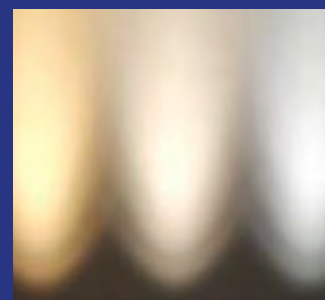

**Several color temperatures**  
Varias temperaturas de color







Honeycomb

# Accessories

---

Honeycomb

35300099

---

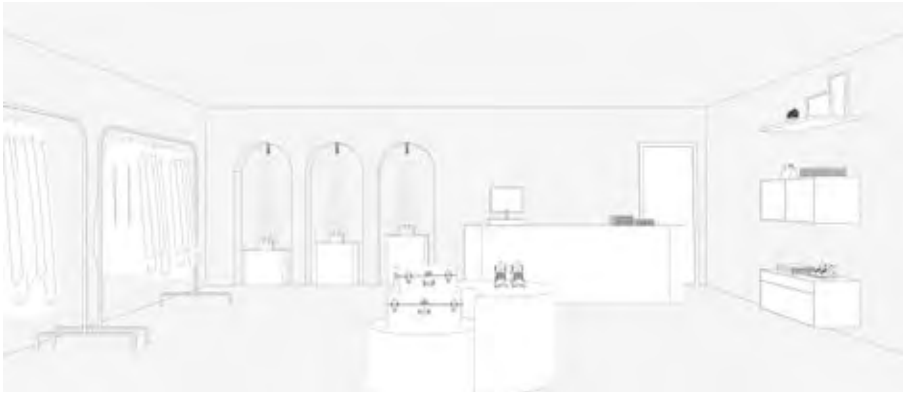

**Retail**



**Restaurant**



**Residential**

## Beam Angle



**11°**



**24°**



**37°**

# UNO DOWNLIGHT 8W

incl. DIM 50.000hs L70 / B10 MacAdam 3 110V 50 / 60Hz 650°C

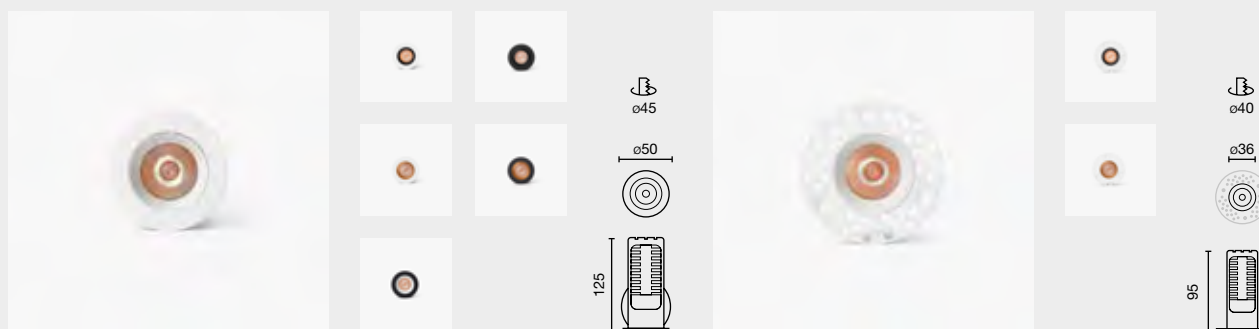

Family	Color T°	Beam Angle	Finish	Ring	Control System	Volt.
<b>0331</b> Uno Trim 8W	<b>927</b> 2700K CRI90	<b>1</b> 11°	<b>1</b> White	<b>1</b> White	<b>D</b> DALI	<b>-110</b> 110V
<b>0332</b> Uno Trimless 8W	<b>930</b> 3000K CRI90	<b>2</b> 24°	<b>2</b> Black	<b>2</b> Black	<b>W</b> CASAMBI	
		<b>3</b> 37°		<b>4</b> Gold	<b>ON/OFF</b>	

**0331**      **927**      **1**      **1**      **1**      **D**      **-110**

Example **0331927111D-110** — Uno trim 8W 2700K CRI90 11° White, White Ring Dali 110V

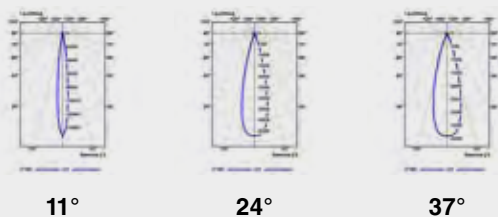

**11°**

**24°**

**37°**

Option	Color T°	CRI	Power	Lumen Output	Beam Angle
927	2700K	90	8W	347lm / 346lm / 331lm	11° / 24° / 37°
930	3000K	90	8W	358lm / 357lm / 341lm	11° / 24° / 37°

The driver requires remote installation due to its size exceeding the dimensions of the ceiling aperture.  
El driver requiere instalación remota debido a que su tamaño excede las dimensiones del hueco del techo.

# UNO PULLDOWN PROJECTOR 8W

incl. DIM 355° 90° 50.000hs L70 / B10 MacAdam 3 110V 50 / 60Hz 650°C

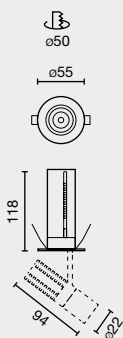
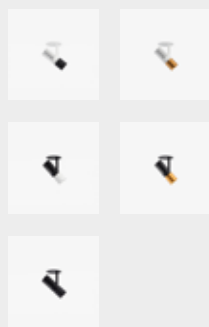

Family	Color T°	Beam Angle	Finish	Ring	Control System	Volt.
0333 Uno Pulldown 8W	927 2700K CRI90	1 11°	1 White	1 White	D DALI	-110 110V
	930 3000K CRI90	2 24°	2 Black	2 Black	W CASAMBI	
		3 37°		4 Gold	ON/OFF	

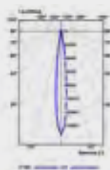

11°

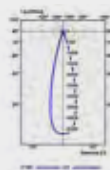

24°

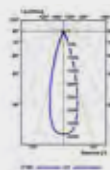

37°

Option	Color T°	CRI	Power	Lumen Output	Beam Angle
927	2700K	90	8W	347lm / 346lm / 331lm	11° / 24° / 37°
930	3000K	90	8W	358lm / 357lm / 341lm	11° / 24° / 37°

The driver requires remote installation due to its size exceeding the dimensions of the ceiling aperture.  
El driver requiere instalación remota debido a que su tamaño excede las dimensiones del hueco del techo.

TEIDE is a modular system of recessed light fixtures which stands out for its great versatility, high visual comfort and the orientability of its modules. Minimalist in design, it offers a broad integration with architecture, ideal for residential and retail use. Committed to lighting excellence with CRI97 and 2 MacAdam options.

TEIDE es un sistema modular de luminarias de empotrar que destaca por su gran versatilidad, alto confort visual y la orientabilidad de sus módulos. De diseño minimalista, ofrece una amplia integración con la arquitectura, ideal para uso residencial y retail. Apuesta por la excelencia lumínica con las opciones IRC97 y 2 MacAdam.





**TEIDE**



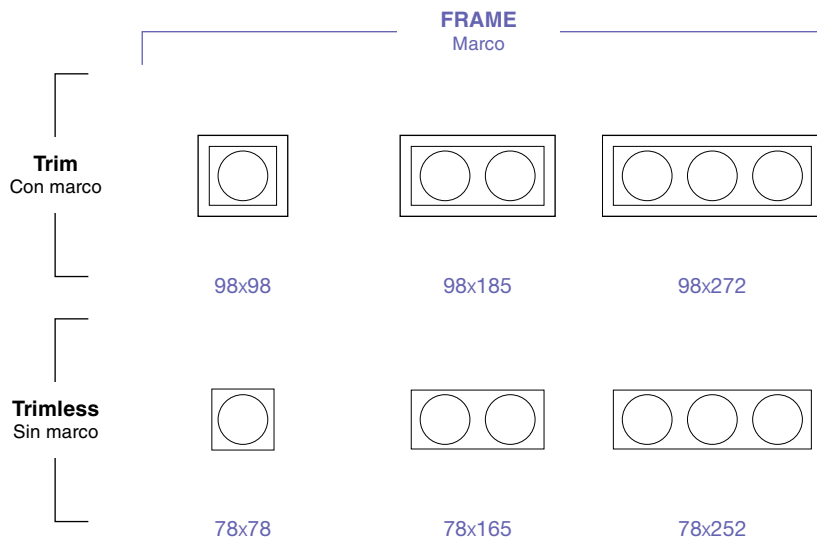
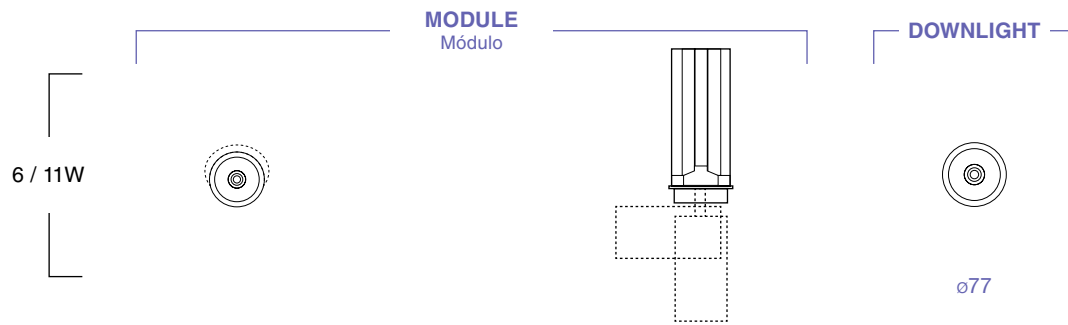

**FINISH**  
Acabado

● **Black**  
Negro

○ **White**  
Blanco

**COLOR TEMPERATURE**  
Temperatura de color

2700K CRI90

3000K CRI90

2700K CRI97

3000K CRI97

**BEAM ANGLE**  
Ángulo de apertura

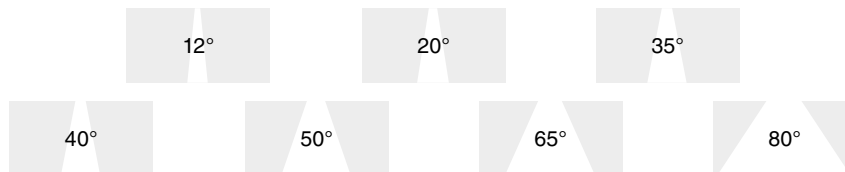

**CONTROL SYSTEM**  
Sistema de control



# Highlights

## Teide system



Trim 1L

Trim 2L

Trim 3L



Trimless 1L

Trimless 2L

Trimless 3L

The system consists of a round downlight module and a spotlight module that can be combined in square/rectangular recessed frames with 1, 2 and 3 lights (also available in frameless version). The downlight module is also available in a round hole installation version, TEIDE Downlight.

El sistema se compone de un módulo redondo tipo downlight y de otro tipo proyector que se pueden combinar entre sí en marcos de empotrar cuadrados/rectangulares de 1, 2 y 3 luces (también disponibles en versión sin marco). El módulo tipo downlight está además disponible en su versión de instalación para agujero redondo, TEIDE Downlight.



Pulldown projector module

## Teide downlight



**Orientation without light loss**  
Orientación sin pérdida de luz





Trim 1L



Trim 2L

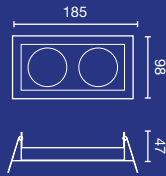

Trim 3L

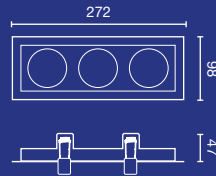

Trimless 1L

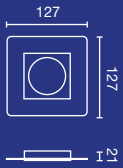

Trimless 2L

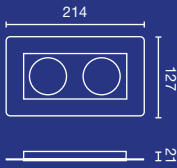

Trimless 3L

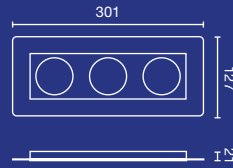

# Frames

Trim 1L	Trim 2L	Trim 3L	Trimless 1L	Trimless 2L	Trimless 3L
● 034600011	● 034600021	● 034600031	● 034700011	● 034700021	● 034700031
● 034600012	● 034600022	● 034600032	● 034700012	● 034700022	● 034700032



**Retail**



**Restaurant**



**Residential**

**Beam Angle Downlight**

**Beam Angle Projector**



**40°**



**50°**

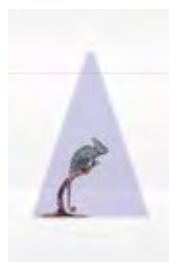

**65°**

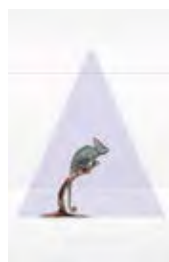

**80°**



**12°**



**20°**



**35°**

# TEIDE PROJECTOR MODULE

incl. DIM 355° 80° 50.000hs L70 / B10 MacAdam 2&3 110V 50 / 60Hz 650°C

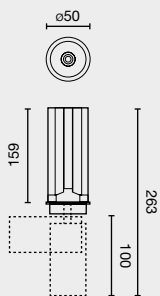

Family	Color T°	Beam Angle	Finish	Control System	Volt.
0349 Teide Projector Module 9W	927 2700K CRI90	1 12°	1 White	D	-110 110V
	930 3000K CRI90	2 20°		C	
	X27 2700K CRI97	3 35°		ON/OFF	
	X30 3000K CRI97				

0349 927 1 1 D -110

Example **034992711D-110** — Teide Projector Module 9W 2700K CRI90 12° White Dali 110V

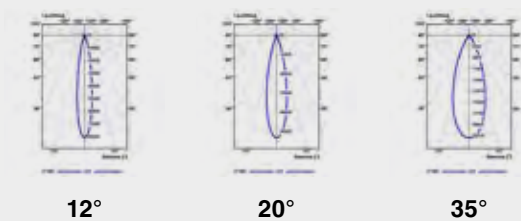

Option	Color T°	CRI	Power	Lumen Output	Beam Angle
927	2700K	90	9W	741lm / 754lm / 782lm	12° / 20° / 35°
X27		97	9W	667lm / 678lm / 703lm	12° / 20° / 35°
930	3000K	90	9W	764lm / 777lm / 806lm	12° / 20° / 35°
X30		97	9W	687lm / 699lm / 725lm	12° / 20° / 35°

See frame options on page 206  
Ver opciones de marco en página 206



# TEIDE DOWNLIGHT MODULE

incl. DIM 355° 45° 50.000hs L70 / B10 MacAdam 2&3 110V 50 / 60Hz 650°C

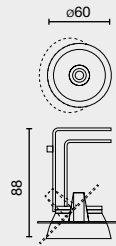

Family	Color T°	Beam Angle	Finish	Control System	Volt.
0352 Teide Downlight Module 10W	927 2700K CRI90	4 40°	1 White	D C ON/OFF	-110 110V
	930 3000K CRI90	5 50°	2 Black		
	X27 2700K CRI97	6 65°			
	X30 3000K CRI97	8 80°			

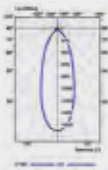

40°



50°



65°



80°

Option	Color T°	CRI	Power	Lumen Output	Beam Angle
927	2700K	90	10W	774lm / 769lm / 783lm / 812lm	40° / 50° / 65° / 80°
X27		97	10W	697lm / 692lm / 704lm / 731lm	40° / 50° / 65° / 80°
930	3000K	90	10W	798lm / 793lm / 807lm / 837lm	40° / 50° / 65° / 80°
X30		97	10W	718lm / 714lm / 726lm / 753lm	40° / 50° / 65° / 80°

See frame options on page 206  
Ver opciones de marco en página 206



# TEIDE DOWNLIGHT

incl. DIM 355° 45° 50.000hs L70 / B10 MacAdam 2&3 110V 50 / 60Hz 650°C

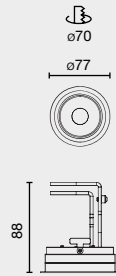

Family	Color T°	Beam Angle	Finish	Control System	Volt.
0348 Teide Downlight 10W	927 2700K CRI90	4 40°	1 White	D DALI C TRIAC ON/OFF	-110 110V
	930 3000K CRI90	5 50°	2 Black		
	X27 2700K CRI97	6 65°			
	X30 3000K CRI97	8 80°			

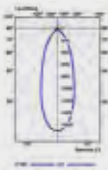

40°



50°



65°



80°

Option	Color T°	CRI	Power	Lumen Output	Beam Angle
927	2700K	90	10W	774lm / 769lm / 783lm / 812lm	40° / 50° / 65° / 80°
X27		97	10W	697lm / 692lm / 704lm / 731lm	40° / 50° / 65° / 80°
930	3000K	90	10W	798lm / 793lm / 807lm / 837lm	40° / 50° / 65° / 80°
X30		97	10W	718lm / 714lm / 726lm / 753lm	40° / 50° / 65° / 80°

TULIPA is the ideal solution when light quality and great visual comfort are needed. Downlight with aluminium injection frame and high-quality finishes which, thanks to its cut-off and its integrated honeycomb, guarantees maximum visual comfort.

TULIPA es la solución ideal cuando se precisa calidad de luz y gran confort visual. Downlight con marco de inyección de aluminio y acabados de alta calidad que, gracias a su cut-off y su panel de abeja integrado, garantiza el máximo confort visual.



# TULIPA





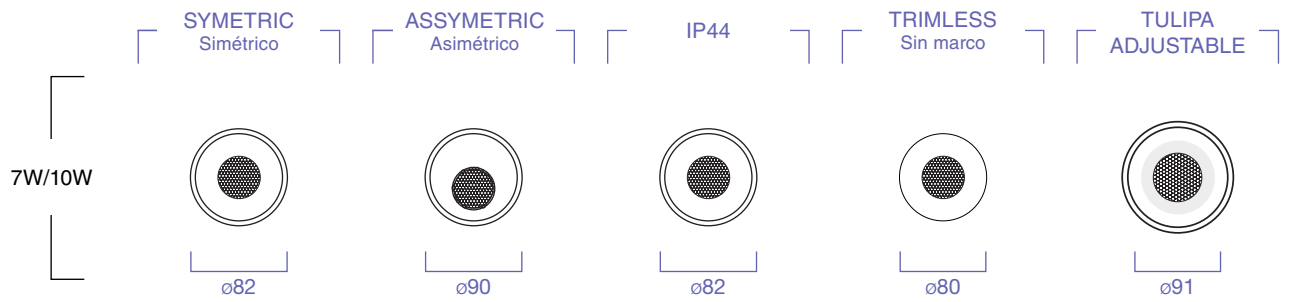

**FINISH**  
Acabado

- Black**  
Negro
- White**  
Blanco



**COLOR TEMPERATURE**  
Temperatura de color

- 2700K CRI90
- 3000K CRI90
- 4000K CRI90

**BEAM ANGLE**  
Ángulo de apertura



**ACCESSORIES**  
Accesorios

-   
Supplementary  
White Ring
-   
Supplementary  
Black Ring

**CONTROL SYSTEM**  
Sistema de control





# Highlights

**Optical block formed by a secondary aluminium injection reflector which at the same time functions as a recess ring, integrated honeycomb, along with a high-purity PMMA lens.**

Bloque óptico formado por un reflector secundario de inyección de aluminio que a la vez ejerce de aro de empotramiento, panel de abeja integrado junto con una lente de PMMA de alta pureza.



**Built-in Honeycomb**  
Panel de abeja incorporado



**Symmetric / Asymmetric / Adjustable**  
Simétrico / Asimétrico / Orientable



**Simple clipping system**  
Sistema de clipaje simple



**Optional IP44**  
Opción IP44



**High CRI**  
Alto IRC

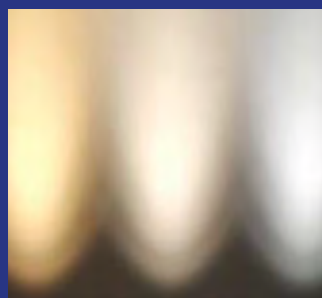

**Several color temperatures**  
Varias temperaturas de color



Need consulting  
for your project?  
¿Necesitas  
asesoramiento  
para tu proyecto?





**Supplementary  
White Ring**

ø96 supplementary ring



**Supplementary  
Black Ring**

ø96 supplementary ring

# Accessories

**Supplementary  
White Ring**

033500098

**Supplementary  
Black Ring**

033500099



**Residential**



**Office**



**Restaurant**

## Beam Angle



**15°**



**24°**



**36°**



**55°**

# TULIPA

incl. DIM 50.000hs L80 / B10 MacAdam 3 110V 50 / 60Hz 650°C

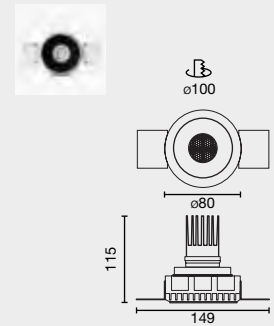
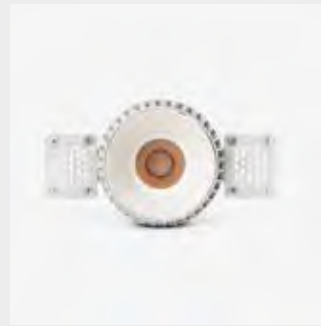
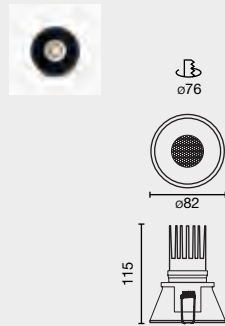

Family	Power	Color T°	Beam Angle	Finish	Control System	Volt.
<b>0335</b> Tulipa Trim	<b>1</b> 7W 350mA	<b>927</b> 2700K CRI90	<b>1</b> 15°	<b>1</b> White	<b>C</b> ON/OFF	<b>-110</b> 110V
<b>0337</b> Tulipa Trim IP44	<b>2</b> 10W 500mA	<b>930</b> 3000K CRI90	<b>2</b> 24°	<b>2</b> Black		
<b>0338</b> Tulipa Trimless		<b>940</b> 4000K CRI90	<b>3</b> 36° <b>5</b> 55°			

0335 1 927 1 1 W

Example **0335192711W** — Tulipa trim 7W 350mA 2700K CRI90 15° White Casambi

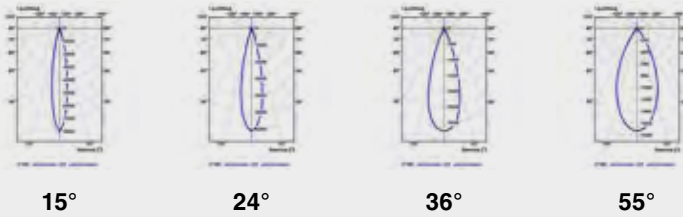

Option	Color T°	CRI	Power	Lumen Output	Beam Angle
0335 / 0337 / 0338	2700K	90	7W 350mA	355lm / 387lm / 406lm / 313lm	15° / 24° / 36° / 55°
		90	10W 500mA	504lm / 550lm / 577lm / 445lm	15° / 24° / 36° / 55°
0335 / 0337 / 0338	3000K	90	7W 350mA	366lm / 399lm / 419lm / 323lm	15° / 24° / 36° / 55°
		90	10W 500mA	520lm / 567lm / 595lm / 459lm	15° / 24° / 36° / 55°
0335 / 0337 / 0338	4000K	90	7W 350mA	377lm / 411lm / 432lm / 333lm	15° / 24° / 36° / 55°
		90	10W 500mA	535lm / 584lm / 613lm / 472lm	15° / 24° / 36° / 55°



# TULIPA ASYMMETRIC

incl. DIM 50.000hs L80 / B10 MacAdam 3 110V 50 / 60Hz 650°C

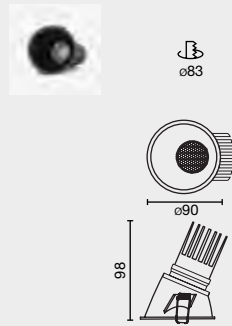

Family	Power	Color T°	Beam Angle	Finish	Control System	Volt.
0336 Tulipa Asymmetric	1 7W 350mA	927 2700K CRI90	1 15°	1 White	C  ON/OFF	-110 110V
	2 10W 500mA	930 3000K CRI90	2 24°	2 Black		
		940 4000K CRI90	3 36°			
			5 55°			

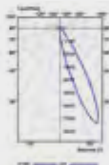

\*15°

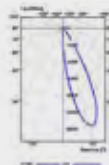

\*24°

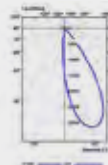

\*36°

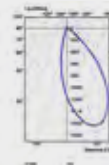

\*55°

Option	Color T°	CRI	Power	Lumen Output	Beam Angle
0336	2700K	90	7W 350mA	333lm / 377lm / 465lm / 320lm	15° / 24° / 36° / 55°
		90	10W 500mA	472lm / 536lm / 660lm / 455lm	15° / 24° / 36° / 55°
0336	3000K	90	7W 350mA	343lm / 389lm / 479lm / 330lm	15° / 24° / 36° / 55°
		90	10W 500mA	487lm / 552lm / 680lm / 469lm	15° / 24° / 36° / 55°
0336	4000K	90	7W 350mA	353lm / 401lm / 493lm / 340lm	15° / 24° / 36° / 55°
		90	10W 500mA	502lm / 569lm / 701lm / 483lm	15° / 24° / 36° / 55°

\*Beam angle with 30° inclination  
\*Ángulo con 30° inclinación

# TULIPA ADJUSTABLE

incl. DIM 25° 50.000hs L80 / B10 MacAdam 3 110V 50 / 60Hz 650°C

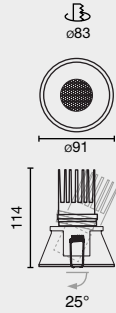

Family	Power	Color T°	Beam Angle	Finish	Control System	Volt.
0339 Tulipa adjustable	1 7W 350mA	927 2700K CRI90	1 15°	1 White	C  ON/OFF	-110 110V
	2 10W 500mA	930 3000K CRI90	2 24°	2 Black		
		940 4000K CRI90	3 36°			
			5 55°			

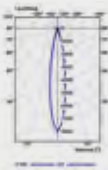

15°

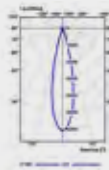

24°

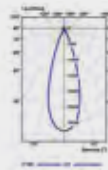

36°

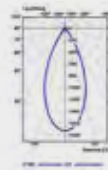

55°

Option	Color T°	CRI	Power	Lumen Output	Beam Angle
0339	2700K	90	7W 350mA	355lm / 387lm / 406lm / 313lm	15° / 24° / 36° / 55°
		90	10W 500mA	504lm / 550lm / 577lm / 445lm	15° / 24° / 36° / 55°
0339	3000K	90	7W 350mA	366lm / 399lm / 419lm / 323lm	15° / 24° / 36° / 55°
		90	10W 500mA	520lm / 567lm / 595lm / 459lm	15° / 24° / 36° / 55°
0339	4000K	90	7W 350mA	377lm / 411lm / 432lm / 333lm	15° / 24° / 36° / 55°
		90	10W 500mA	535lm / 584lm / 613lm / 472lm	15° / 24° / 36° / 55°







PODIUM is a modular system of recessed and surface light fixtures which offers different light effects and configurations, enabling the creation of different climates with an integrated aesthetic. One product, one project, infinite possibilities.

PODIUM es un sistema modular de luminarias de empotrar y de superficie que ofrece diferentes efectos lumínicos y configuraciones permitiendo generar diversos climas con una estética integrada. Un producto, un proyecto, infinitas posibilidades.

# PODIUM





Podium Collection



Surface  
299

1392

**MODULE**  
Modulo

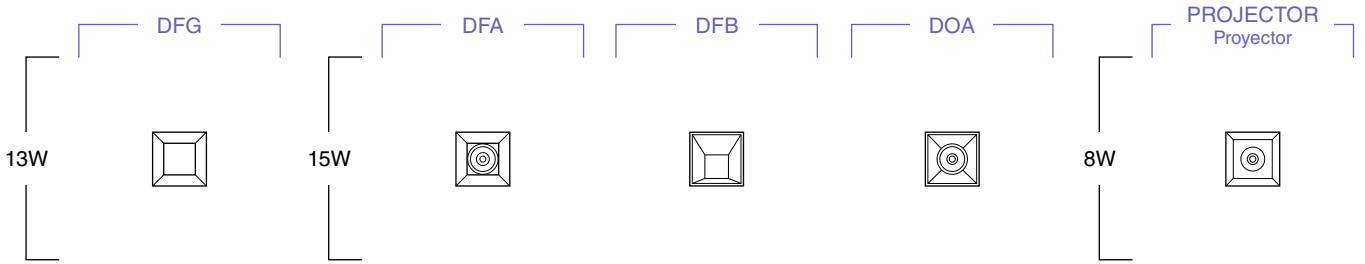

**FRAME**  
Marco

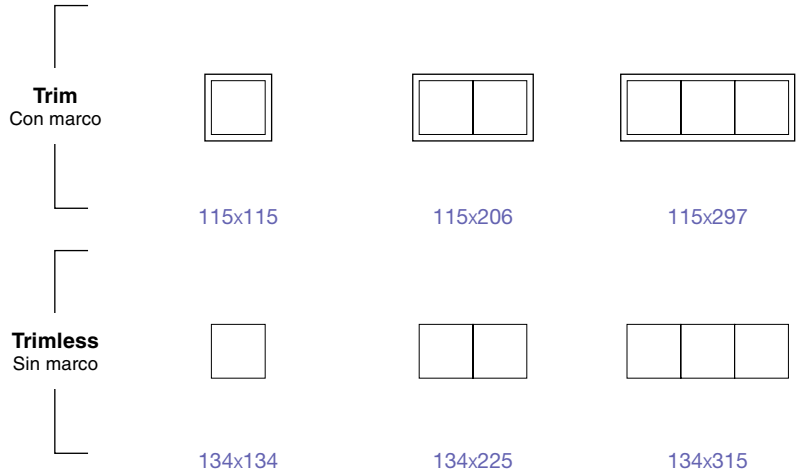

**FINISH**  
Acabado

- Black**  
Negro
- White**  
Blanco

**COLOR TEMPERATURE**  
Temperatura de color

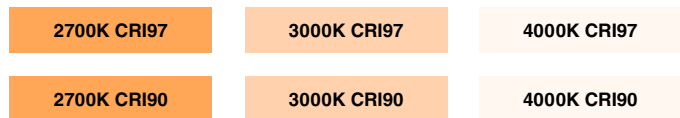

**BEAM ANGLE**  
Ángulo de apertura



**ACCESSORIES**  
Accesorios



**CONTROL SYSTEM**  
Sistema de control



# Highlights

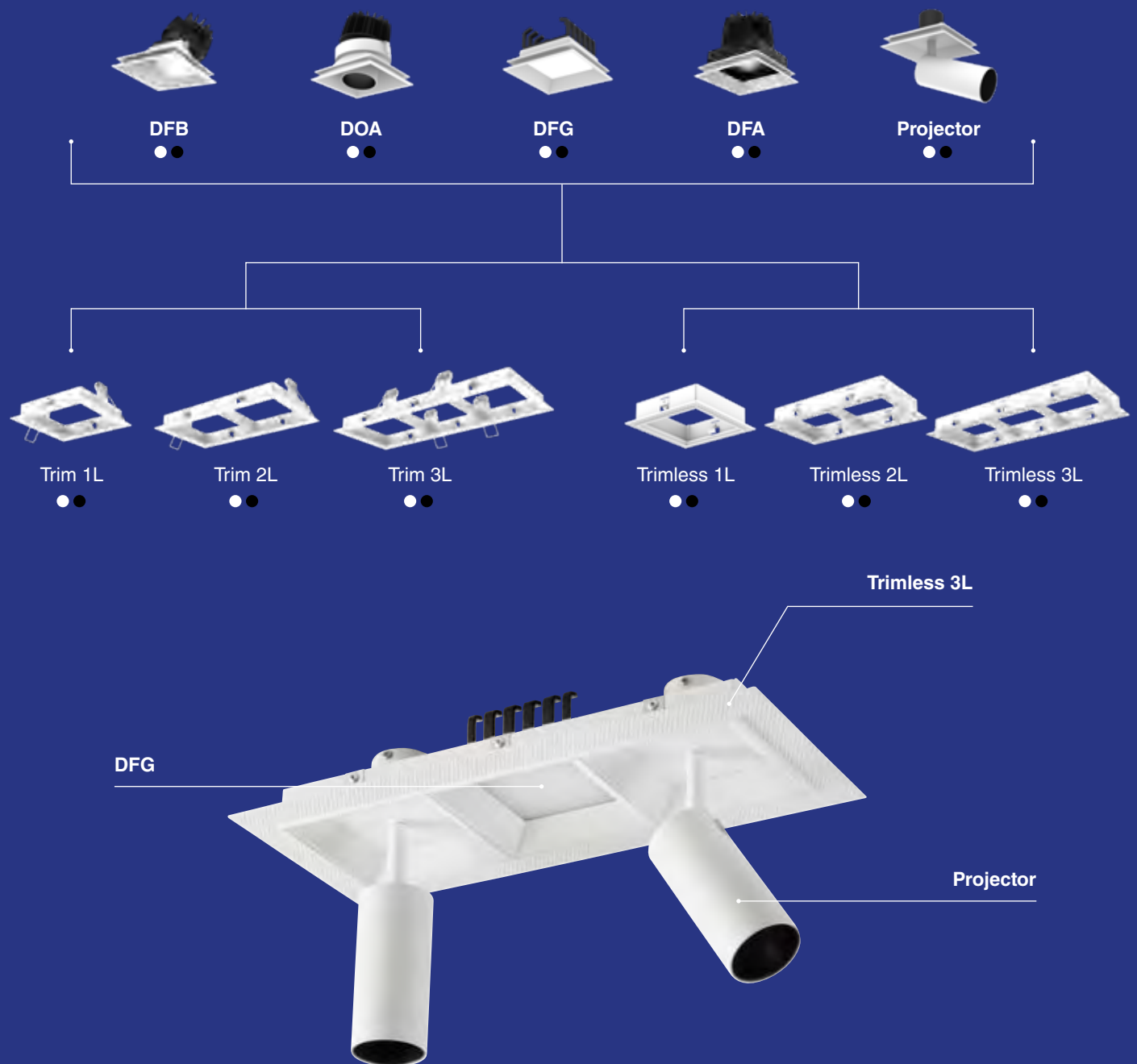

The recessed system has options with and without a frame of 1, 2 and 3 lights, making it possible to combine general, downlight, fixed and orientable accent and projector lighting optics into one product. The family is offered in 3 colour temperatures and high CRI.

El sistema empotrable cuenta con opciones con y sin marco de 1,2 y 3 luces pudiendo combinar en un mismo producto ópticas de iluminación general, bañador, acento fija y orientable y proyector. La familia se ofrece en 3 temperaturas de color y alto IRC.

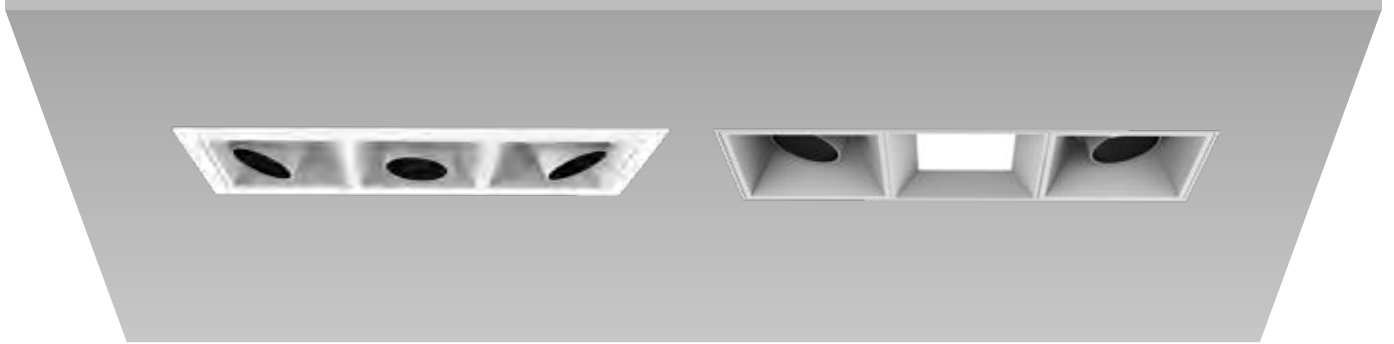



103x103

Trim 1L

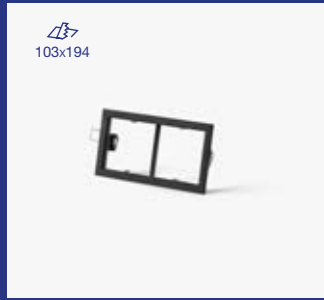
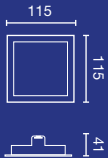

103x194

Trim 2L

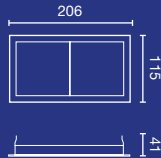

103x285

Trim 3L

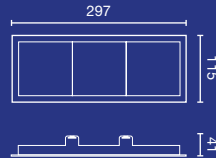

98x98

Trimless 1L

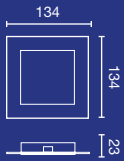

98x189

Trimless 2L

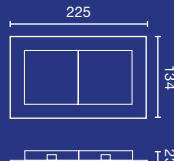

98x279

Trimless 3L

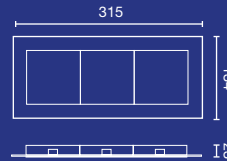

Honeycomb



Stripped Glass



Diffusion Sheet

# Frames

# Accessories for DFA&DOA

Trim 1L	Trim 2L	Trim 3L	Trimless 1L	Trimless 2L	Trimless 3L
● 034100011	● 034100021	● 034100031	● 034200011	● 034200021	● 034200031
● 034100012	● 034100022	● 034100032	● 034200012	● 034200022	● 034200032

Honeycomb	Stripped Glass	Diffusion sheet
034100098	034100097	034100099





**Residential**



**Restaurant**

## Beam Angle



**15°**



**24/25°**



**35/38°**



**60°**



**90°**



**110°**

# PODIUM DFA MODULE

incl. DIM 50.000hs L70 / B10 MacAdam 3 110V 50 / 60Hz 650°C



Family	Color T°	Beam Angle	Finish	Control System	Volt.
0341 Podium DFA Module 15W	927 2700K CRI97	1 15°	1 White	W CASAMBI	-110 110V
	930 3000K CRI97	2 24°	2 Black	D DALI	
	940 4000K CRI97	3 38°		C TRIAC	
		6 60°		ON/OFF	

0341 927 1 1 W -110

Example **034192711W-110** — Podium DFA 15W 2700K CRI97 15° White Casambi 110V

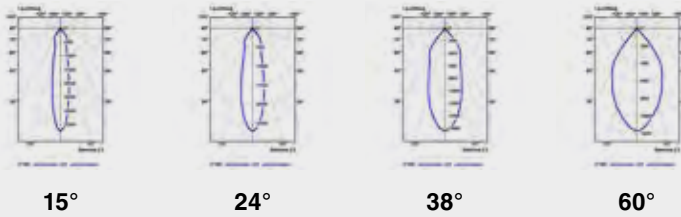

Option	Color T°	CRI	Power	Lumen Output	Beam Angle
X27	2700K	97	15W	1121lm / 1026lm / 1036lm / 1060lm	15° / 24° / 38° / 60°
X30	3000K	97	15W	1156lm / 1058lm / 1068lm / 1093lm	15° / 24° / 38° / 60°
X40	4000K	97	15W	1191lm / 1090lm / 1100lm / 1126lm	15° / 24° / 38° / 60°

# PODIUM DOA MODULE

incl. DIM 355° 20° 50.000hs L70 / B10 MacAdam 3 110V 50 / 60Hz 650°C

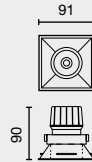

Family	Color T°	Beam Angle	Finish	Control System	Volt.
0342 Podium DOA Module 15W	927 2700K CRI97	1 15°	1 White	W CASAMBI	-110 110V
	930 3000K CRI97	2 24°	2 Black	D DALI	
	940 4000K CRI97	3 38°		C TRIAC	
		6 60°		ON/OFF	

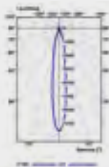

15°

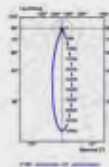

24°

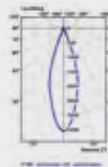

38°

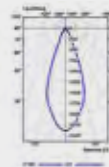

60°

Option	Color T°	CRI	Power	Lumen Output	Beam Angle
X27	2700K	97	15W	435lm / 439lm / 448lm / 456lm	15° / 24° / 38° / 60°
X30	3000K	97	15W	448lm / 453lm / 462lm / 470lm	15° / 24° / 38° / 60°
X40	4000K	97	15W	461lm / 467lm / 476lm / 484lm	15° / 24° / 38° / 60°

# PODIUM DFB MODULE

incl. DIM 50.000hs L70 / B10 MacAdam 3 110V 50 / 60Hz 650°C

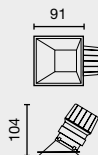

Family	Color T°	Beam Angle	Finish	Control System	Volt.
0344 Podium DFB Module 15W	927 2700K CRI97	9 90°	1 White	W CASAMBI D DALI C TRIAC ON/OFF	-110 110V
	930 3000K CRI97		2 Black		
	940 4000K CRI97				

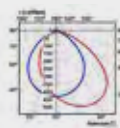

90°

Option	Color T°	CRI	Power	Lumen Output	Beam Angle
X27	2700K	97	15W	228lm	90°
X30	3000K	97	15W	235lm	90°
X40	4000K	97	15W	242lm	90°





# PODIUM PROJECTOR MODULE

incl. DIM 355° 90° 50.000hs L70 / B10 MacAdam 3 110V 50 / 60Hz 650°C

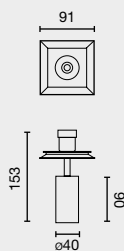

Family	Color T°	Beam Angle	Finish	Control System	Volt.
0345 Podium Projector Module 8W	927 2700K CRI97	1 15°	1 White	W CASAMBI	-110 110V
	930 3000K CRI97	2 25°	2 Black	D DALI	
	940 4000K CRI97			C TRIAC	
				ON/OFF	

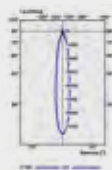

15°

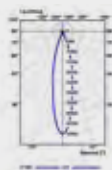

25°

Option	Color T°	CRI	Power	Lumen Output	Beam Angle
X27	2700K	97	8W	273lm / 273lm	15° / 25°
X30	3000K	97	8W	281lm / 281lm	15° / 25°
X40	4000K	97	8W	289lm / 289lm	15° / 25°

# PODIUM DFG MODULE

incl. DIM 50.000hs L70 / B10 MacAdam 3 110V 50 / 60Hz 650°C



Family	Color T°	Beam Angle	Finish	Control System	Volt.
0343 Podium DFG Module 13W	927 2700K CRI90	0 110°	1 White	W CASAMBI D DALI C TRIAC ON/OFF	-110 110V
	930 3000K CRI90		2 Black		
	940 4000K CRI90				



110°

Option	Color T°	CRI	Power	Lumen Output	Beam Angle
927	2700K	90	13W	648lm	110°
930	3000K	90	13W	668lm	110°
940	4000K	90	13W	688lm	110°

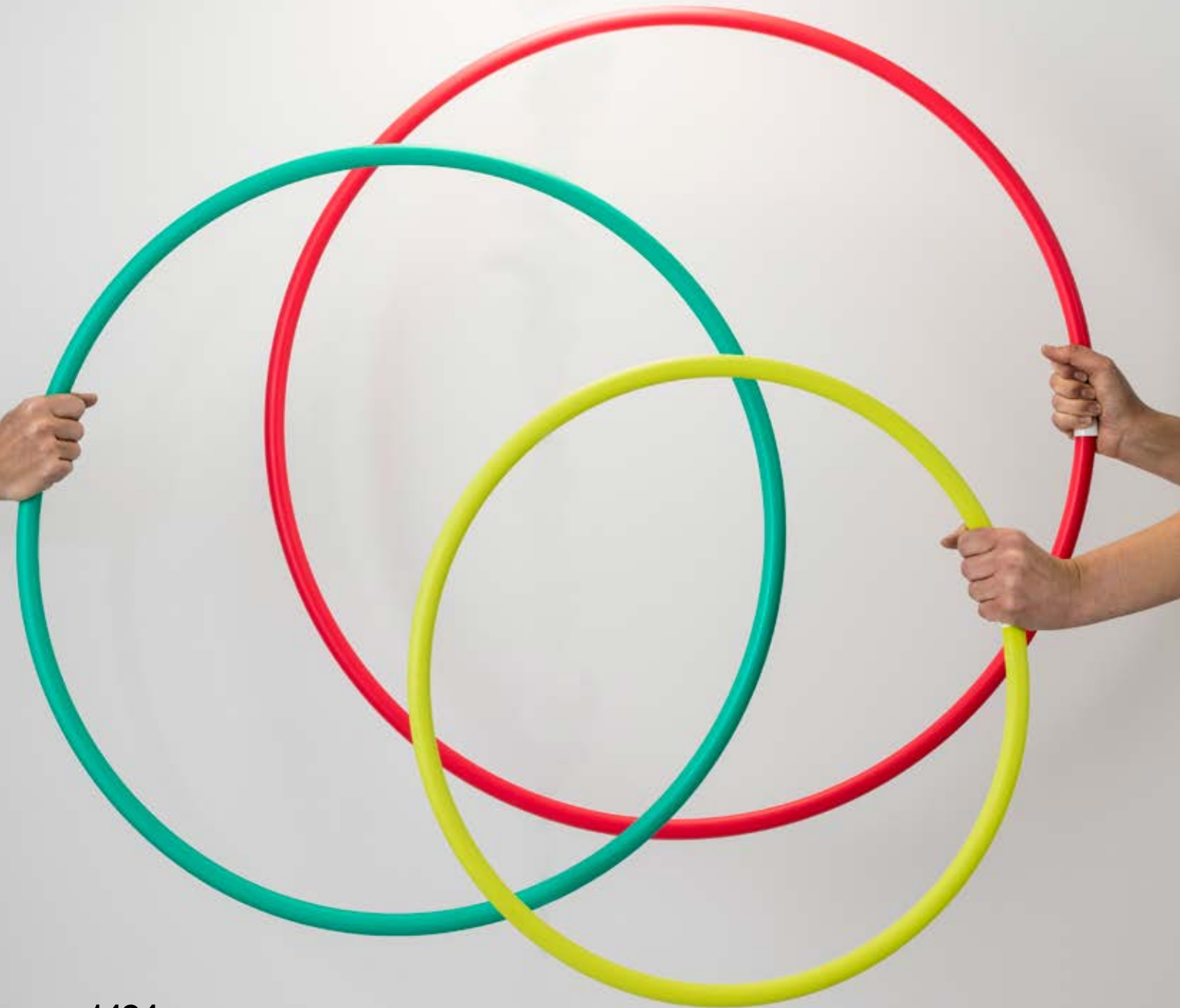

S U R F A C E



DOMIO is a family of circular light fixtures with pure lines. Its different sizes and installation options make it an ideal solution for the lighting of big spaces like lobbies, conference rooms and restaurants. Its glare control options and tunable white make it a perfect option for work zones and spaces dedicated to healthcare.

DOMIO es una familia de luminarias circulares de líneas puras. Sus diferentes tamaños y opciones de instalación la convierten en una solución ideal para la iluminación de grandes espacios como vestíbulos, salas de conferencias y restaurantes. Sus opciones con el control del deslumbramiento y tunable white hacen que sea una opción perfecta para zonas de trabajo y espacios dedicados a la salud.





# DOMIO

Surface

1407



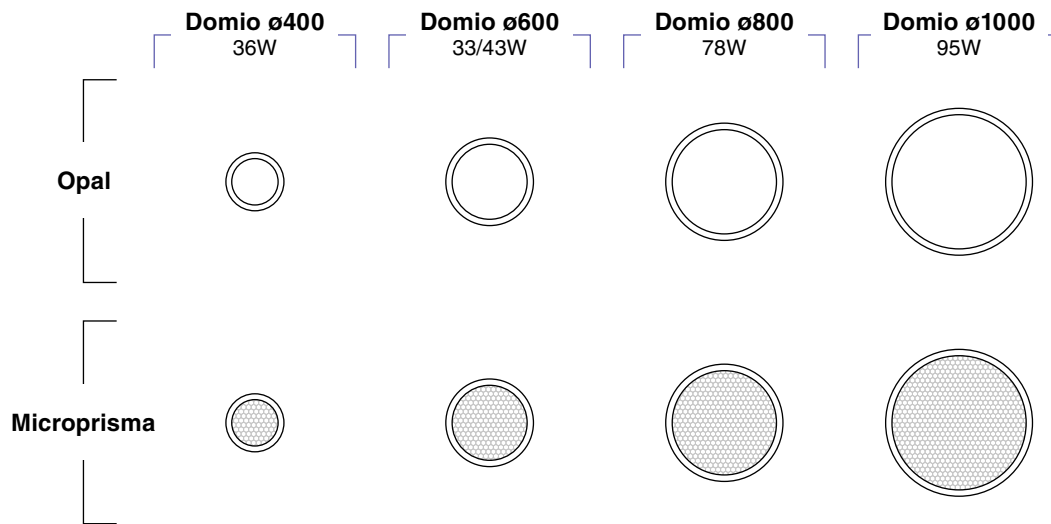

**FINISH**  
Acabado

● **Black**  
Negro

○ **White**  
Blanco

**COLOR TEMPERATURE**  
Temperatura de color

3000K

4000K

2700-6500K

**ACCESSORIES**  
Accesorios



Suspended

**CONTROL SYSTEM**  
Sistema de control



CASAMBI



# Highlights

Available in 4 sizes of 400 mm, 600 mm, 800 mm and 1000 mm with two optics variants: opal high-transmittance PMMA to offer uniform and microprismatic general lighting for applications where glare control is required. Its UGR<19 make it an ideal option for office or continuous work applications.

Disponible en 4 tamaños de 400mm, 600mm, 800mm y 1000mm con dos variantes de ópticas: PMMA opal de alta transmitancia para ofrecer una iluminación general uniforme y micro prismática para aplicaciones donde el control de deslumbramiento es una necesidad. Su UGR<19 lo convierten en una opción ideal para aplicaciones de oficina o de trabajo en continuo.



Opal diffuser

Microprisma diffuser

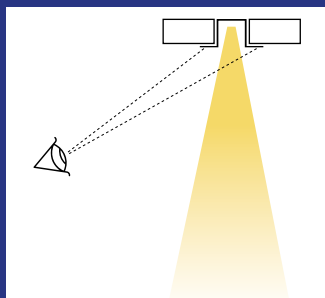

UGR<19

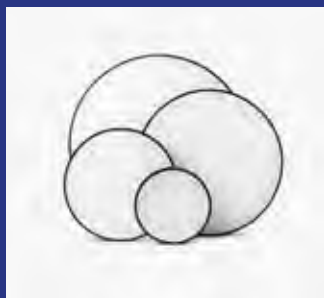

Different sizes  
Diversos tamaños



Tunable white



Semi Recessed option  
Opción semi empotrado



Wall & ceiling  
Aplique y plafón



Suspended option  
Opción colgante



Surface

1411





**Suspended**

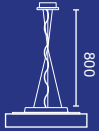

# Accesories

---

**Suspended**

● 050000097

● 050000098

---



Office



Restaurant



Retail

## Beam Angle



90°



110°

# DOMIO ø400 36W

incl. DIM 50.000hs L80 / B10 MacAdam 3 110V 50 / 60Hz 650°C UGR <19

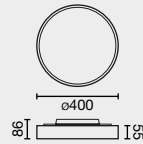
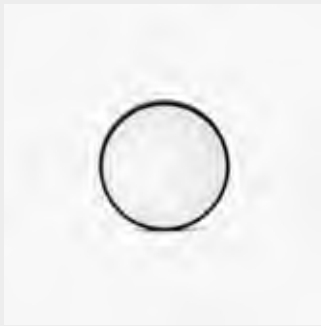

Family	Color T°	Diffuser	Finish	Control System	Volt.
0414 Domio ø400 36W	830 3000K CRI80	1 Opal	1 White	W CASAMBI D DALI ON/OFF	-110 110V
	840 4000K CRI80	2 Microprisma	2 Black		

0414 830 1 1 D -110

Example **041483011D-110** — Domio ø400 36W 3000K Opal Diffusor White DALI 110V



**90°**  
microprisma





**110°**  
opal

Option	Color T°	CRI	Power	Lumen Output	Diffuser
830	3000K	80	36W	3861lm	Opal
				3047lm	Microprisma
840	4000K	80	36W	3977lm	Opal
				3138lm	Microprisma

# DOMIO ø600 43W

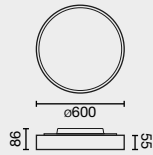
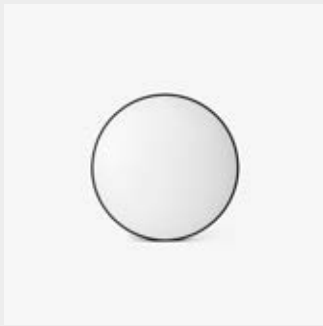
 incl. 
  DIM 
  50.000hs L80 / B10 
 
 MacAdam 3 
 110V 
  50 / 60Hz 650°C 
  UGR <19



Family	Color T°	Diffuser	Finish	Control System	Volt.
0415 Domio ø600 43W	830 3000K CRI80	1 Opal	1 White	D  0 - 10 ON/OFF	-110 110V
	840 4000K CRI80	2 Microprisma	2 Black		



**90°**  
microprisma

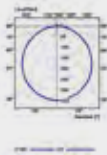

**110°**  
opal

Option	Color T°	CRI	Power	Lumen Output	Diffuser
830	3000K	80	43W	4725lm	Opal
				4059lm	Microprisma
840	4000K	80	43W	4867lm	Opal
				4181lm	Microprisma

# DOMIO ø800 78W

incl. DIM 50.000hs L80 / B10 MacAdam 3 110V 50 / 60Hz 650°C UGR <19

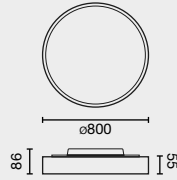
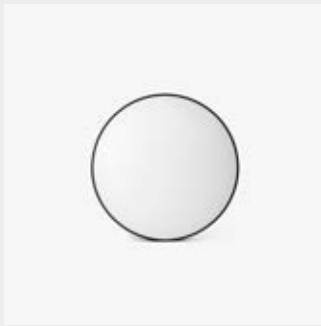

Family	Color T°	Diffuser	Finish	Control System	Volt.
0416 Domio ø800 78W	830 3000K CRI80	1 Opal	1 White	D  0 - 10 ON/OFF	-110 110V
	840 4000K CRI80	2 Microprisma	2 Black		

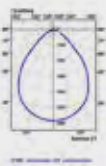

**90°**  
microprisma



**110°**  
opal

Option	Color T°	CRI	Power	Lumen Output	Diffuser
830	3000K	80	78W	8174lm	Opal
				7022lm	Microprisma
840	4000K	80	78W	8419lm	Opal
				7232lm	Microprisma



# DOMIO ø1000 95W

incl. DIM 50.000hs L80 / B10 MacAdam 3 110V 50 / 60Hz 650°C UGR <19

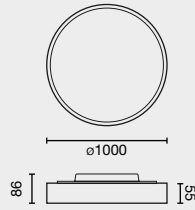

Family	Color T°	Diffuser	Finish	Control System	Volt.
0417 Domio ø1000 95W	830 3000K CRI80	1 Opal	1 White	D 0 - 10 ON/OFF	-110 110V
	840 4000K CRI80	2 Microprisma	2 Black		



**90°**  
microprisma



**110°**  
opal

Option	Color T°	CRI	Power	Lumen Output	Diffuser
830	3000K	80	95W	10490lm	Opal
				9010lm	Microprisma
840	4000K	80	95W	10804lm	Opal
				9281lm	Microprisma

The SCUBA UGR luminaire is a versatile and watertight solution suitable for surface or suspension installation. It provides high-quality lighting with a Unified Glare Rating (UGR) of less than 19, making it perfect for office environments. Its industrial style adds a touch of modernity and uniqueness to any workspace while providing efficient and comfortable lighting. It is the ideal choice for creating office environments with an industrial aesthetic and optimal lighting.

La luminaria SCUBA UGR es una solución versátil y estanca, adecuada para su instalación en superficie o suspensión. Brinda una iluminación de alta calidad con un valor UGR (Deslumbramiento Unificado) menor a 19, lo que la hace perfecta para entornos de oficina. Su estilo industrial añade un toque de modernidad y singularidad a cualquier espacio de trabajo, a la vez que proporciona una iluminación eficiente y confortable. Es la elección ideal para crear ambientes de oficina con una estética industrial y una iluminación óptima.



# SCUBA



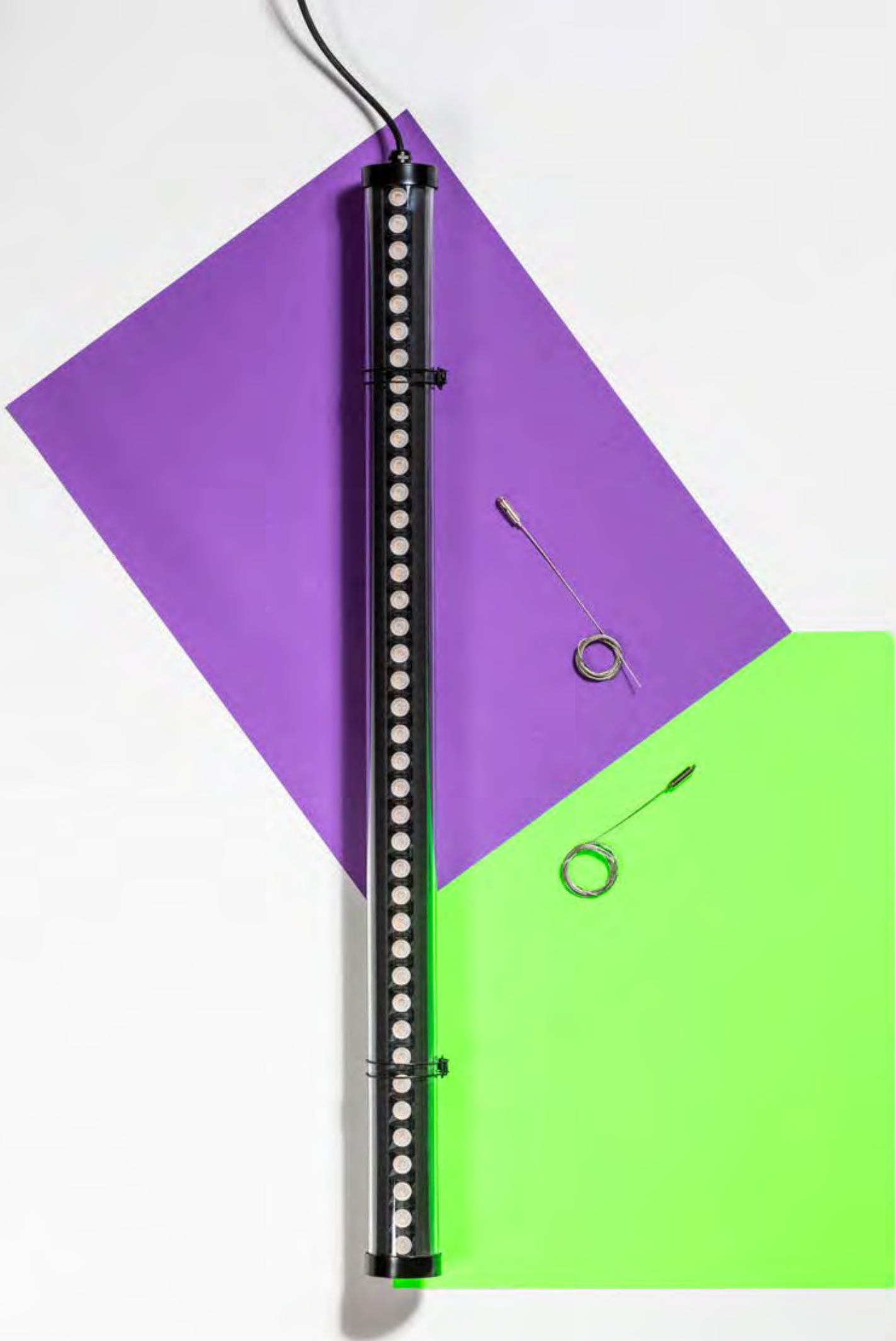

**Scuba 1200mm**  
36W

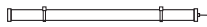

---

**FINISH**  
Acabado

- **Black**  
Negro

---

**COLOR TEMPERATURE**  
Temperatura de color

3000K

4000K

---

**ACCESSORIES**  
Accesorios



Suspended

---

**CONTROL SYSTEM**  
Sistema de control





# Highlights

With a low UGR glare index, this linear luminaire becomes the ideal choice for both office environments and industrial spaces requiring a high IP rating. In addition, its remarkable impact resistance ensures reliable performance even in demanding work environments. With these features, the luminaire not only provides quality lighting but also ensures long-term durability and safety in various work settings.

Con un bajo índice de deslumbramiento UGR, esta luminaria lineal se convierte en la elección ideal tanto para entornos de oficina como para espacios industriales que requieran una clasificación de protección IP alta. Además, su notable resistencia al impacto garantiza un rendimiento confiable incluso en entornos de trabajo exigentes. Con estas características, la luminaria no solo proporciona una iluminación de calidad, sino que también asegura durabilidad y seguridad a largo plazo en diversos entornos laborales.

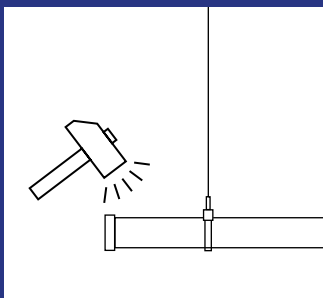

IK10

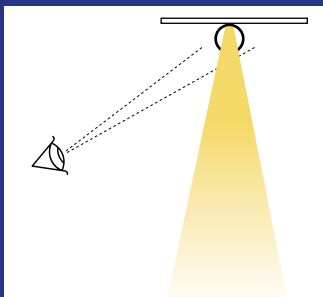

UGR < 19



Suspended option  
Opción colgante



IP65



High CRI  
Alto IRC





**Suspended**

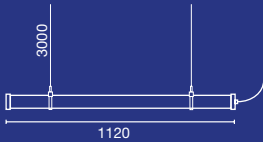

# Accessories

**Suspended**

● 042500099

**Suspended DALI**

● 042500099D



Office

## Beam Angle



50°

# SCUBA UGR 36W

NEW

incl. DIM 50.000hs L80 / B10 MacAdam 3 IP65 110V 50 / 60Hz 650°C

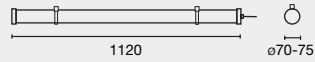

Family	Color T°	Beam Angle	Finish	Control System	Volt.
--------	----------	------------	--------	----------------	-------

0425 Scuba UGR 36W	930 3000K CRI90	5 50°	2 Black	D  ON/OFF	-110 110V
	940 4000K CRI90				

0425 930 5 2 D -110

Example **042593052D-110** — Scuba UGR 36D3000K CRI90 50° Black DALI 110V

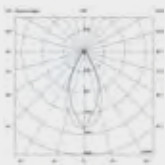

60°

Option	Color T°	CRI	Power	Lumen Output	Beam Angle
930	3000K	90	36W	2946lm	50°
940	4000K	90	36W	3034lm	50°







PROOFLINE is a rugged and high-performance linear luminaire designed for demanding environments. With an IP67 rating, it offers exceptional resistance to water and dust, making it ideal for applications in parking lots and industrial spaces where durability and reliability are crucial. Thanks to its high luminous efficiency up to 150lm/w, it provides efficient and bright lighting while reducing energy consumption. It is an ideal solution for challenging environments that require durable and efficient lighting.

PROOFLINE es una luminaria lineal resistente y de alto rendimiento diseñada para entornos exigentes. Con clasificación IP67, ofrece una excepcional resistencia al agua y al polvo, lo que la hace ideal para aplicaciones en estacionamientos y espacios industriales donde la durabilidad y la fiabilidad son fundamentales. Gracias a su alta eficiencia lumínica de hasta 150lm/w, proporciona una iluminación eficiente y brillante a la vez que reduce el consumo energético. Es una solución ideal para entornos desafiantes que requieren de una iluminación duradera y eficiente.

# PROOF LINE







**Proofline**

[ 27 - 33 - 39 - 45W ]



---

**FINISH**  
Acabado

**White**  
Blanco

---

**COLOR TEMPERATURE**  
Temperatura de color

**3000K CRI80**

**4000K CRI80**



# Highlights

Its high efficiency makes this luminaire the ideal option for extensive spaces that demand constant illumination, such as parking lots. Its impact resistance ensures exceptional durability, ensuring flawless operation, providing reliable and long-lasting lighting over time.

Su alta eficiencia convierte a esta luminaria en la opción ideal para espacios extensos que demandan iluminación constante, como por ejemplo, parkings. Su resistencia al impacto garantiza una durabilidad excepcional, lo que asegura un funcionamiento impecable, proporcionando una iluminación fiable y duradera a lo largo del tiempo.



**IP65**

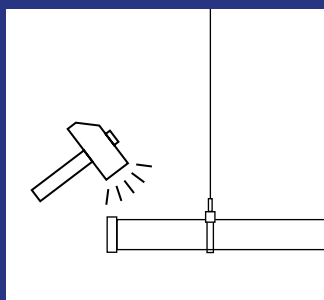

**IK10**

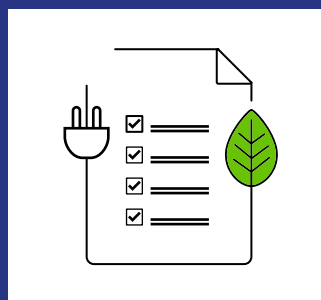

**High Efficiency**  
Alta eficiencia

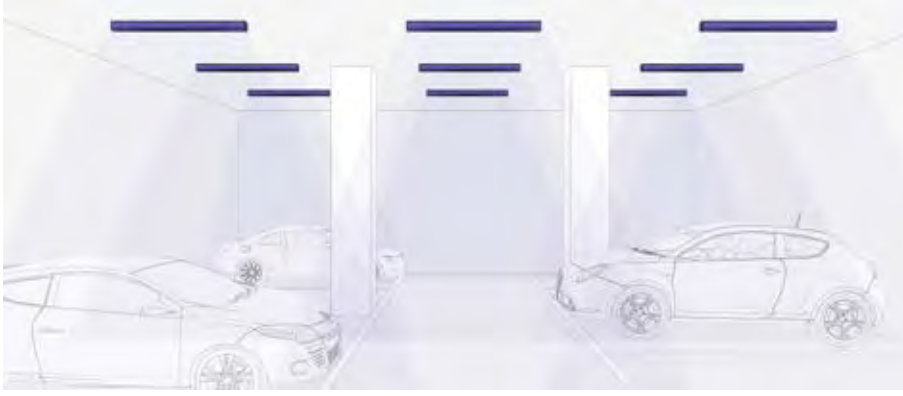

Parking

## Beam Angle



120°

# PROOFLINE 45W



incl. DIM 50.000hs L80 / B10 MacAdam 3 IP65 110V 50 / 60Hz 650°C

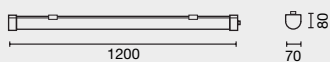

Family	Color T°	Beam Angle	Finish	Control System	Volt.
<b>0424</b> Proofoffline 45W	<b>830</b> 3000K CRI80 <b>840</b> 4000K CRI80	<b>9</b> 120°	<b>3</b> White	ON/OFF	<b>-110</b> 110V

**0424**      **830**      **9**      **3**      **D**      **-110**

Example **042483093D-110** — Proofoffline 45W 3000K CRI80 120° White Dali 110V

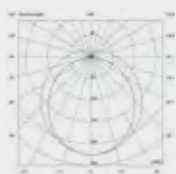

120°

Option	Color T°	CRI	Power	Lumen Output	Beam Angle
830	3000k	80	27W	3915lm	120°
840	4000k	80	27W	4032lm	120°
830	3000k	80	33W	4766lm	120°
840	4000k	80	33W	4908lm	120°
830	3000k	80	39W	5576lm	120°
840	4000k	80	39W	5743lm	120°
830	3000k	80	45W	6369lm	120°
840	4000k	80	45W	6914lm	120°

\*Este producto integra un driver que permite cambiar la potencia de forma manual. Para realizar el cambio de potencia consultar el instructivo.  
 \*This product integrates a driver that allows manual adjustment of power. To change the power, please refer to the instructions.



Surface light fixture suitable for ceilings which do not offer recessed mounting. The versatility of sizes and optics of FOST CEILING makes it a perfect fixed overhead application solution for commercial spaces, hotels, restaurants, retail and even domestic spaces due to its various colour temperature and CRI options.

Luminaria de superficie indicada para techos sin posibilidad de empotramiento. La versatilidad de tamaños y ópticas de FOST CEILING lo convierten en una solución perfecta de aplicación fija cenital para espacios comerciales, hoteles, restauración, retail e incluso espacios domésticos por sus varias opciones en temperatura de color y IRC.





# F O S T



# C E I L I N G



FOST Collection



Track  
47



Recessed  
171



Pulldown  
181



Surface  
267



Pendant  
323

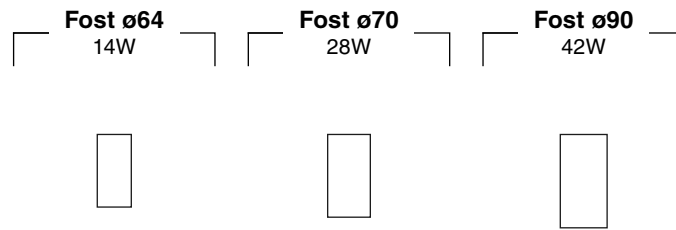

**FINISH**  
Acabado

- Black**  
Negro
  **White**  
Blanco

**COLOR TEMPERATURE**  
Temperatura de color

2700K CRI90	3000K CRI90	4000K CRI90
2700K CRI97	3000K CRI97	4000K CRI97
MEAT	BREAD	FASHION

**BEAM ANGLE**  
Ángulo de apertura



**ACCESSORIES**  
Accesorios

- |   |   |  |
|---|---|--|
| <br>Honeycomb    | <br>Long Snoot | <br>Striped Glass |
| <br>Spread Glass | <br>White Ring | <br>Copper Ring   |

**CONTROL SYSTEM**  
Sistema de control





White Ring



Copper Ring



Striped Glass



Long Snoot

Its multiple accessories and combinations facilitate the product's personalisation, giving it certain architectural relevance and at the same time making it possible to modify the beam or reduce glare.

Sus múltiples accesorios y combinaciones facilitan la personalización del producto, que hace posible la modificación de haz o reducir el deslumbramiento.



Spread Glass



Honeycomb



Without accessory

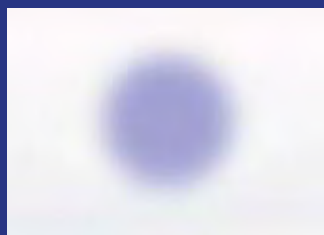

Spread Glass



Striped Glass

# Accesorios

	Honeycomb	White Ring	Copper Ring	Spread Glass	Long Snoot	Striped Glass
ø64	011700094	011700099	011700098	011700097	011700095	011700096
ø70	011800094	011800099	011800098	011800097	011800095	011800096
ø90	012100094	012100099	012100098	012100097	012100095	012100096



**Retail**



**Restaurant**

## Beam Angle



**17/18°**



**23/25°**



**35/36/38°**



**60°**



# FOST CEILING $\phi 64$

incl. 50.000hs L80 / B10 MacAdam 2&3 110V 50 / 60Hz 650°C



Family	Color T°	Beam Angle	Finish	Control System	Volt.
0510 Fost ceiling $\phi 64$ 14W	927 2700K CRI90	1 17°	1 White	C  ON/OFF	-110 110V
	930 3000K CRI90	2 25°	2 Black		
	940 4000K CRI90	3 35°			
	X27 2700K CRI97 <span style="background-color: purple; color: white; border-radius: 50%; padding: 2px;">N</span>	6 60°			
	X30 3000K CRI97				
	X40 4000K CRI97				

Example **051092711C-110** — Fost Ceiling  $\phi 64$  14W 2700K CRI90 17° White Triac 110V

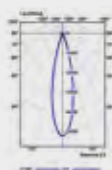

17°

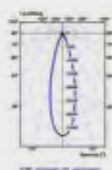

25°

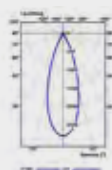

35°

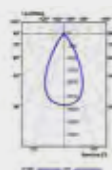

60°

Option	Color T°	CRI	Power	Lumen Output	Beam Angle
927	2700K	90	14W	950lm / 1076lm / 1127lm / 1248lm	17° / 25° / 35° / 60°
X27		97	14W	855lm / 1968lm / 1014lm / 1123lm	17° / 25° / 35° / 60°
930	3000K	90	14W	979lm / 1109lm / 1162lm / 1287lm	17° / 25° / 35° / 60°
X30		97	14W	881lm / 998lm / 1046lm / 1159lm	17° / 25° / 35° / 60°
940	4000K	90	14W	1008lm / 1142lm / 1197lm / 1326lm	17° / 25° / 35° / 60°
X40		97	14W	908lm / 1028lm / 1077lm / 1193lm	17° / 25° / 35° / 60°

# FOST CEILING $\phi$ 70

incl. 50.000hs L80 / B10 MacAdam 2&3 110V 50 / 60Hz 650°C



Family	Color T°	Beam Angle	Finish	Control System	Volt.
0511 Fost ceiling $\phi$ 70 28W	927 2700K CRI90	1 18°	1 White	C  ON/OFF	-110 110V
	930 3000K CRI90	2 23°	2 Black		
	940 4000K CRI90	3 36°			
	X27 2700K CRI97	6 60°			
	X30 3000K CRI97				
	X40 4000K CRI97				

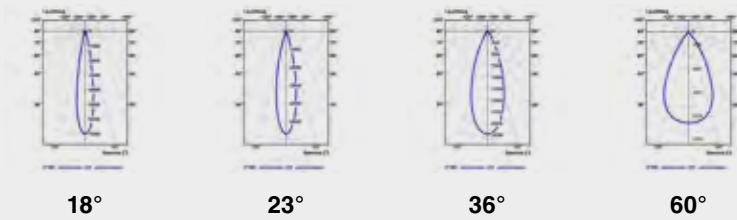

Option	Color T°	CRI	Power	Lumen Output	Beam Angle
927	2700K	90	28W	2982lm / 2987lm / 2732lm / 2436lm	18° / 23° / 36° / 60°
X27		97	28W	2684lm / 2688lm / 2459lm / 2193lm	18° / 23° / 36° / 60°
930	3000K	90	28W	3075lm / 3080lm / 2817lm / 2512lm	18° / 23° / 36° / 60°
X30		97	28W	2767lm / 2771lm / 2535lm / 2261lm	18° / 23° / 36° / 60°
940	4000K	90	28W	3167lm / 3172lm / 2902lm / 2588lm	18° / 23° / 36° / 60°
X40		97	28W	2850lm / 2855lm / 2611lm / 2328lm	18° / 23° / 36° / 60°

# FOST CEILING ø90

incl. DIM 50.000hs L80 / B10 MacAdam 2&3 110V 50 / 60Hz 650°C



Family	Color T°	Beam Angle	Finish	Control System	Volt.
0512 Fost ceiling ø90 42W	927 2700K CRI90	1 18°	1 White	C  ON/OFF	-110 110V
	930 3000K CRI90	2 23°	2 Black		
	940 4000K CRI90	3 38°			
	X27 2700K CRI97				
	X30 3000K CRI97				
	X40 4000K CRI97				
	MT MEAT				
	BR BREAD				
	FS FASHION				

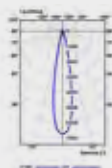

18°

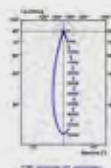

23°

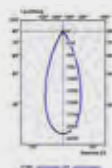

38°

Option	Color T°	CRI	Power	Lumen Output	Beam Angle
927	2700K	90	42W	3374lm / 3656lm / 3856lm	18° / 23° / 38°
X27	2700K	97	42W	3036lm / 3290lm / 3470lm	18° / 23° / 38°
930	3000K	90	42W	3478lm / 3769lm / 3975lm	18° / 23° / 38°
X30	3000K	97	42W	3130lm / 3392lm / 3577lm	18° / 23° / 38°
940	4000K	90	42W	3582lm / 3882lm / 4094lm	18° / 23° / 38°
X40	4000K	97	42W	3224lm / 3493lm / 3684lm	18° / 23° / 38°
MT	3100K	-	42W	2468lm / 2688lm / 2819lm	18° / 23° / 38°
BR	2500K	-	42W	3330lm / 3627lm / 3803lm	18° / 23° / 38°
FS	3100K	-	42W	3418lm / 3723lm / 3903lm	18° / 23° / 38°



Need consulting  
for your project?  
¿Necesitas  
asesoramiento  
para tu proyecto?



PODIUM is a modular system of recessed and surface light fixtures which offers different light effects and configurations, enabling the creation of different climates with an integrated aesthetic. One product, one project, infinite possibilities.

PODIUM es un sistema modular de luminarias de empotrar y de superficie que ofrece diferentes efectos lumínicos y configuraciones permitiendo generar diversos climas con una estética integrada. Un producto, un proyecto, infinitas posibilidades.







# PODIUM



PODIUM Collection



Downlight  
225

1448

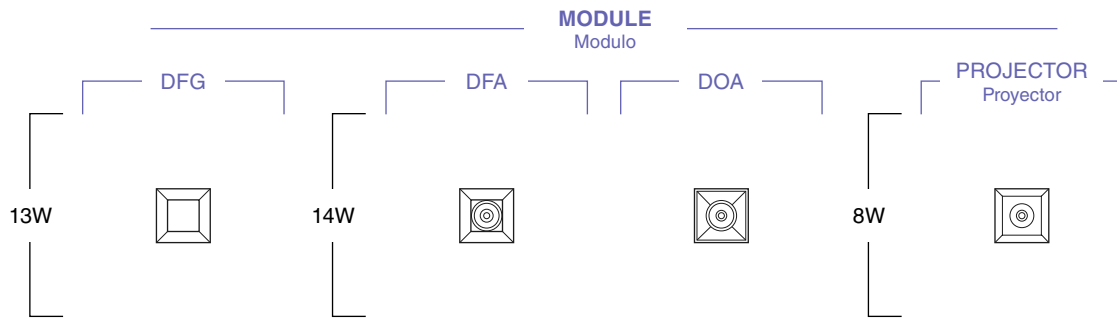

**SURFACE BOX**  
Caja de superficie

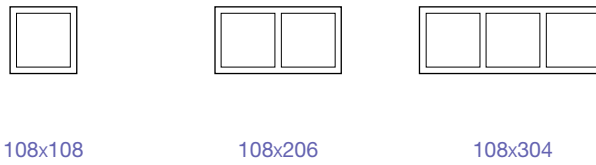

**FINISH**  
Acabado

- Black**  
Negro
- White**  
Blanco

**COLOR TEMPERATURE**  
Temperatura de color

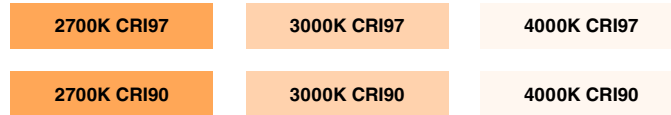

**BEAM ANGLE**  
Ángulo de apertura



**ACCESSORIES**  
Accesorios



**CONTROL SYSTEM**  
Sistema de control



# Highlights

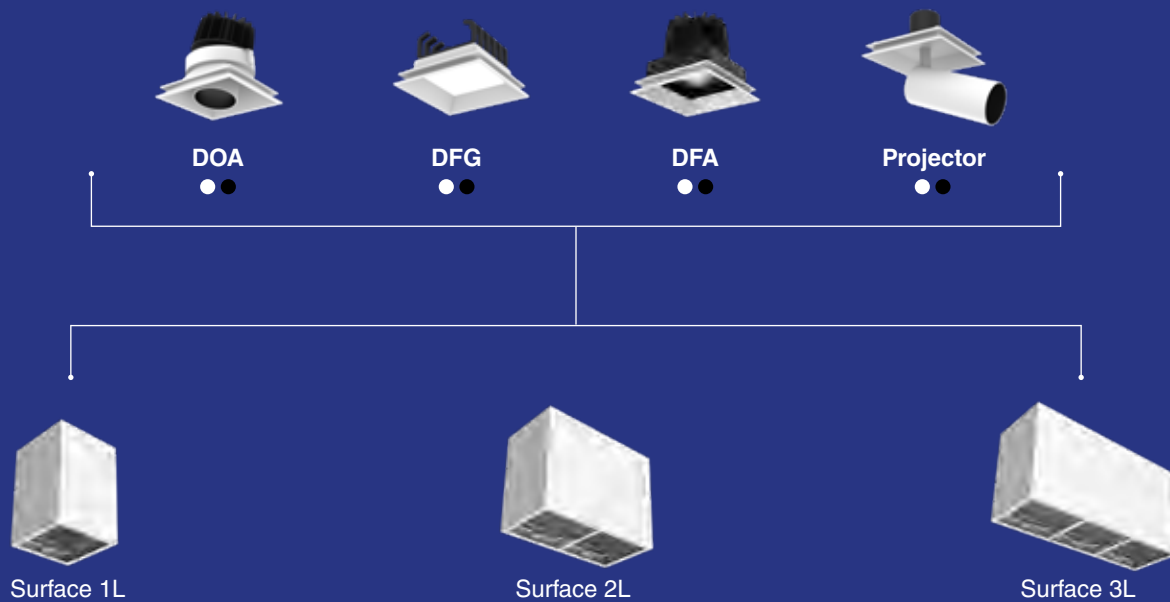







Surface box 1L

Surface box 2L

Surface box 3L

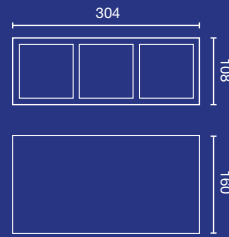
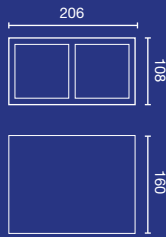
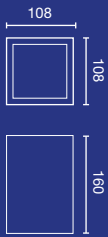

Honeycomb



Stripped Glass



Diffusion Sheet

# Surface box

# Accessories for DFA&DOA

Surface box 1L	Surface box 2L	Surface box 3L
● 051300011	● 051400021	● 051500031
● 051300012	● 051400022	● 051500032

Honeycomb	Stripped Glass	Diffusion sheet
034100098	034100097	034100099



**Residential**



**Restaurant**

## Beam Angle



**18°**



**24/25°**



**35/38°**



**60°**



**90°**



**110°**

# PODIUM DFA MODULE

incl. DIM 50.000hs L70 / B10 MacAdam 3 110V 50 / 60Hz 650°C

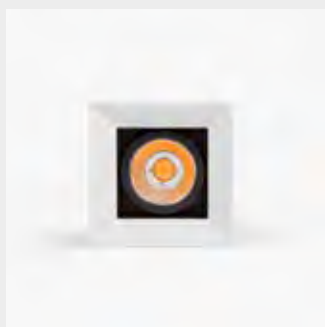

Family	Color T°	Beam Angle	Finish	Control System	Volt.
0341 Podium DFA Module 15W	927 2700K CRI97	1 15°	1 White	W CASAMBI	-110 110V
	930 3000K CRI97	2 24°	2 Black	D DALI	
	940 4000K CRI97	3 38°		C TRIAC	
		6 60°		ON/OFF	

0341 927 1 1 W -110

Example **034192711W-110** — Podium DFA Module 15W 2700K CRI97 15° White Casambi 110V

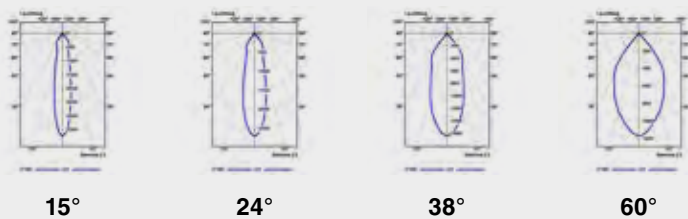

Option	Color T°	CRI	Power	Lumen Output	Beam Angle
X27	2700K	97	15W	1121lm / 1026lm / 1036lm / 1060lm	15° / 24° / 38° / 60°
X30	3000K	97	15W	1156lm / 1058lm / 1068lm / 1093lm	15° / 24° / 38° / 60°
X40	4000K	97	15W	1191lm / 1090lm / 1100lm / 1126lm	15° / 24° / 38° / 60°

See surface box options on page 304  
Ver opciones de caja en página 304

# PODIUM DOA MODULE

incl. DIM 355° 20° 50.000hs L70 / B10 MacAdam 3 110V 50 / 60Hz 650°C



Family	Color T°	Beam Angle	Finish	Control System	Volt.
0342 Podium DOA Module 15W	927 2700K CRI97	1 15°	1 White	W CASAMBI	-110 110V
	930 3000K CRI97	2 24°	2 Black	D DALI	
	940 4000K CRI97	3 38°		C TRIAC	
		6 60°		ON/OFF	

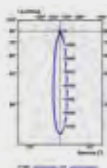

15°

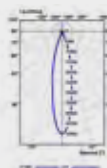

24°

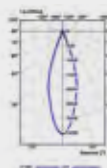

38°

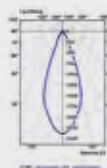

60°

Option	Color T°	CRI	Power	Lumen Output	Beam Angle
X27	2700K	97	15W	435lm / 439lm / 448lm / 456lm	15° / 24° / 38° / 60°
X30	3000K	97	15W	448lm / 453lm / 462lm / 470lm	15° / 24° / 38° / 60°
X40	4000K	97	15W	461lm / 467lm / 476lm / 484lm	15° / 24° / 38° / 60°

See surface box options on page 304  
Ver opciones de caja en página 304

# PODIUM DFG MODULE

incl. DIM 50.000hs L70 / B10 MacAdam 3 110V 50 / 60Hz 650°C

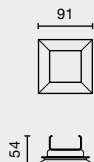

Family	Color T°	Beam Angle	Finish	Control System	Volt.
0344 Podium DFB Module 15W	927 2700K CRI97	9 90°	1 White	W CASAMBI D DALI C TRIAC ON/OFF	-110 110V
	930 3000K CRI97		2 Black		
	940 4000K CRI97				



110°

Option	Color T°	CRI	Power	Lumen Output	Beam Angle
927	2700K	90	13W	648lm	110°
930	3000K	90	13W	668lm	110°
940	4000K	90	13W	688lm	110°

See surface box options on page 304  
Ver opciones de caja en página 304



# PODIUM PROJECTOR MODULE

incl. DIM 355° 90° 50.000hs L70 / B10 MacAdam 3 110V 50 / 60Hz 650°C

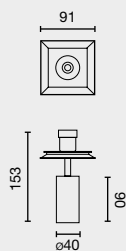

Family	Color T°	Beam Angle	Finish	Control System	Volt.
0345 Podium Projector Module 8W	927 2700K CRI97	1 15°	1 White	W CASAMBI	-110 110V
	930 3000K CRI97	2 25°	2 Black	D DALI	
	940 4000K CRI97			C TRIAC	
				ON/OFF	

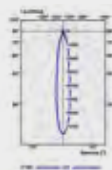

15°

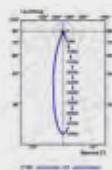

25°

Option	Color T°	CRI	Power	Lumen Output	Beam Angle
X27	2700K	97	8W	273lm / 273lm	15° / 25°
X30	3000K	97	8W	281lm / 281lm	15° / 25°
X40	4000K	97	8W	289lm / 289lm	15° / 25°

See surface box options on page 304  
Ver opciones de caja en página 304



S U S P E N D E D



MUTE makes quite a splash. It is not only a suspension light, but also a way of achieving relaxed spaces and inviting communication. Its textile fabric absorbs reverberation and contributes to the reduction of environmental noise. MUTE no es sólo una luminaria de suspensión. Es la forma de conseguir espacios relajados y que inviten a la comunicación. Su tejido textil absorbe la reverberación y contribuye a la reducción del ruido ambiental.





# MUTE

DESIGNED BY NAHTRANG





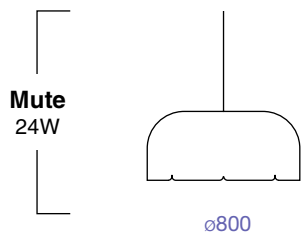

---

**FINISH**  
Acabado

- **Dark Grey+Grey**  
Gris oscuro+Gris
- **Dark Grey+Brown**  
Gris oscuro+Marrón

---

**COLOR TEMPERATURE**  
Temperatura de color

3000K CRI>80

4000K CRI>80

---

**CONTROL SYSTEM**  
Sistema de control



# Highlights

## Recycled PET

Because polyester accounts for approximately 60 percent of the world's production of PET, developing a non-virgin supply chain for polyester fiber has the potential to massively impact global energy and resource requirements.

Debido a que el poliéster representa aproximadamente el 60 por ciento de la producción mundial de PET, el desarrollo de una cadena de suministro no virgen para la fibra de poliéster tiene el potencial de impactar masivamente los requerimientos globales de energía y recursos.

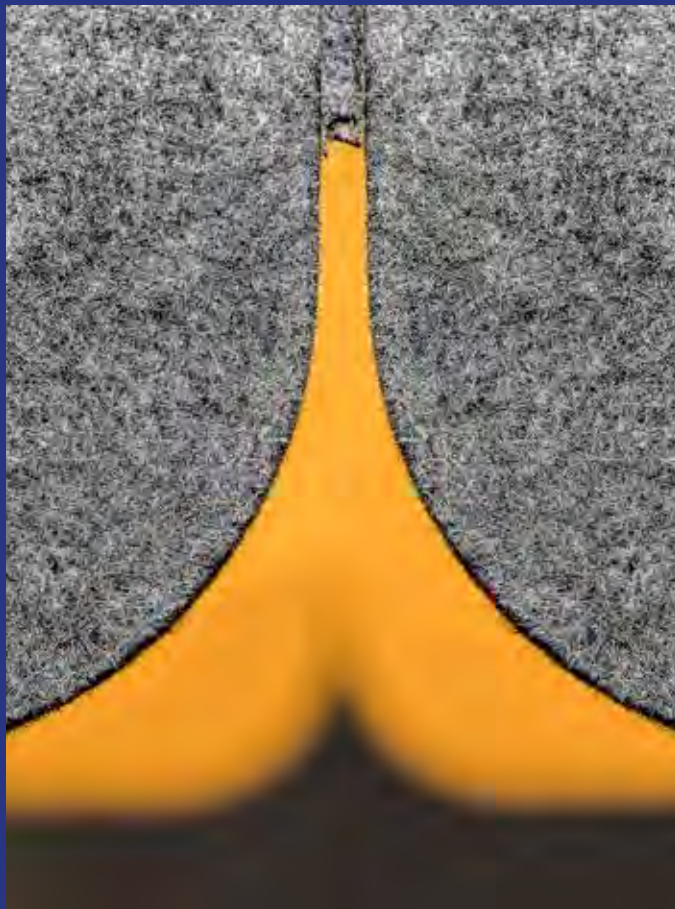

## Sound Absorbing $\alpha = 0.9$

Noise in offices and workplaces has direct consequences on worker performance. The most immediate one is the reduction of their concentration. Workers exposed to continuous noise in their workplace are less effective in their work tasks. Concentration often means giving the brain a break to think better and focus on an activity. Luminaires made from fabrics with noise-absorbing properties are perfect for work spaces with high noise levels and acoustic distractions.

El ruido en las oficinas y lugares de trabajo tiene consecuencias directas en el rendimiento de los trabajadores. La más inmediata es la reducción de su concentración. Los trabajadores expuestos a un ruido continuo en su lugar de trabajo son menos eficaces en sus tareas. La concentración suele significar dar un respiro al cerebro para pensar mejor y centrarse en una actividad. Las luminarias fabricadas con tejidos con propiedades de absorción del ruido son perfectas para espacios de trabajo con altos niveles de ruido y distracciones acústicas.





**Restaurant**



**Office**

## Beam Angle



**90°**





Thanks to BEDEO relational/project



Thanks to Estudio SeQura | Interior designer: Mercè Font





Need consulting  
for your project?  
¿Necesitas  
asesoramiento  
para tu proyecto?

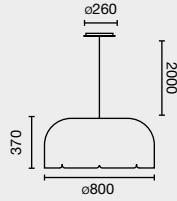

# MUTE ø80 24W

incl. DIM 50.000hs L70 / B10 MacAdam 3 100-240V 50 / 60Hz 850°C UGR <19



Reference	Finish	Power	Color T°	Control System	Volt.
20101	Dark grey+grey	24W	3000K CRI>80	DA 	-110 110V
20102	Dark grey+brown	24W	3000K CRI>80	ON/OFF	
20103	Dark grey+grey	24W	4000K CRI>80		
20104	Dark grey+brown	24W	4000K CRI>80		

20101

DA

-110

Example **20101DA-110** — Mute ø80 24W 3000K CRI>80 Dark Grey+grey Dali 110V

Option	Color T°	CRI	Power	Lumen Output	Beam Angle
20101	3000K	>80	24W	1014lm	90°
20102	3000K	>80	24W	1014lm	90°
20103	4000K	>80	24W	1044lm	90°
20104	4000K	>80	24W	1044lm	90°







FOST PENDANT is a tubular shaped suspended light fixture with a proportion designed to be part of the architecture by providing an aesthetic value and accentuating what needs to be highlighted. Its technical and decorative character, and its multiple options of size, optics, colour temperatures and CRI make it an ideal option for architectural spaces like restaurants, hotels and other spaces where it is necessary to combine aesthetic values and technical lighting.

FOST PENDANT es una luminaria suspendida de forma tubular con una proporción diseñada para formar parte de la arquitectura aportando un valor estético y acentuando lo que debe ser destacado.

Su carácter técnico-decorativo y sus múltiples opciones tanto en tamaños, ópticas, temperaturas de color y IRC, lo convierten en una opción ideal para espacios arquitectónicos como restaurantes, hoteles y otros espacios donde es necesario conjugar valores estéticos e iluminación técnica.





**F O O S T**

**P E N D A N T**

1471





FOST Collection



Track  
47



Recessed  
171



Pulldown  
181



Ceiling  
277



Surface  
267

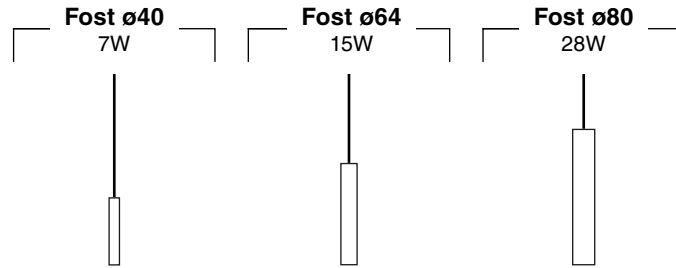

**FINISH**  
Acabado

● **Black**  
Negro

○ **White**  
Blanco

**COLOR TEMPERATURE**  
Temperatura de color

2700K CRI90	3000K CRI90	4000K CRI90
2700K CRI97	3000K CRI97	4000K CRI97
MEAT	BREAD	FASHION

**BEAM ANGLE**  
Ángulo de apertura

17° / 18°	23° / 25°	35° / 38°
-----------	-----------	-----------

**ACCESSORIES**  
Accesorios

		
Honeycomb	White Ring	Copper Ring

**CONTROL SYSTEM**  
Sistema de control





White Ring



Copper Ring



Honeycomb

**Its multiple accessories and combinations facilitate the product's personalisation, giving it certain architectural relevance and at the same time making it possible to modify the beam or reduce glare.**

Sus múltiples accesorios y combinaciones facilitan la personalización del producto que hace posible la modificación de haz o reducir el deslumbramiento.

# Accesorios

	Honeycomb	White Ring	Copper Ring
ø40	-	011500099	011500098
ø64	011700094	011700099	011700098
ø80	011300097	011300099	011300098



**Restaurant**



**Retail**

## Beam Angle



**17/18°**



**23/25°**



**35/38°**



Thanks to EMMME Studio | Photo by Lupe Clemente

**Need consulting  
for your project?**  
¿Necesitas  
asesoramiento  
para tu proyecto?







Suspended

1477

# FOST PENDANT ø40

incl. 50.000hs L80 / B10 MacAdam 2 & 3 110V 50 / 60Hz 650°C



Family	Color T°	Beam Angle	Finish	Volt.
0411 Fost Pendant ø40 7W	927 2700K CRI90	1 18°	1 White	-110 110V
	930 3000K CRI90	2 23°	2 Black	
	940 4000K CRI90	3 35°		
	X27 2700K CRI97			
	X30 3000K CRI97			
	X40 4000K CRI97			

0411 927 1 1 -110

Example **041192711-110** — Fost Pendant ø40 7W 2700K CRI90 18° White 110V

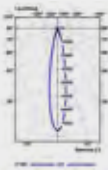

18°

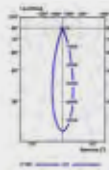

23°

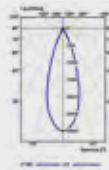

35°

Option	Color T°	CRI	Power	Lumen Output	Beam Angle
927	2700K	90	7W	632lm / 553lm / 586lm	18° / 23° / 35°
X27		97	7W	569lm / 498lm / 527lm	18° / 23° / 35°
930	3000K	90	7W	652lm / 570lm / 604lm	18° / 23° / 35°
X30		97	7W	587lm / 513lm / 544lm	18° / 23° / 35°
940	4000K	90	7W	652lm / 587lm / 622lm	18° / 23° / 35°
X40		97	7W	587lm / 528lm / 560lm	18° / 23° / 35°

# FOST PENDANT ø64

incl. DIM 50.000hs L80 / B10 MacAdam 2 & 3 110V 50 / 60Hz 650°C

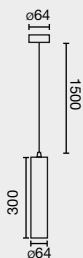

Family	Color T°	Beam Angle	Finish	Volt.
0412 Fost Pendant ø64 14W	927 2700K CRI90	1 17°	1 White	ON/OFF DALI TRIAC -110 110V
	930 3000K CRI90	2 25°	2 Black	
	940 4000K CRI90	3 35°		
	X27 2700K CRI97			
	X30 3000K CRI97			
	X40 4000K CRI97			

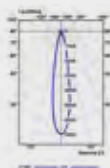

17°

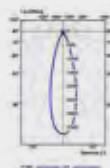

25°

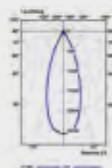

35°

Option	Color T°	CRI	Power	Lumen Output	Beam Angle
927	2700K	90	14W	1372lm / 1553lm / 1503lm	17° / 25° / 35°
X27		97	14W	1235lm / 1398lm / 1352lm	17° / 25° / 35°
930	3000K	90	14W	1414lm / 1601lm / 1549lm	17° / 25° / 35°
X30		97	14W	1273lm / 1441lm / 1394lm	17° / 25° / 35°
940	4000K	90	14W	1457lm / 1650lm / 1596lm	17° / 25° / 35°
X40		97	14W	1311lm / 1484lm / 1436lm	17° / 25° / 35°

# FOST PENDANT ø80

incl. DIM 50.000hs L80 / B10 MacAdam 2 & 3 110V 50 / 60Hz 650°C

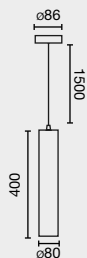

Family	Color T°	Beam Angle	Finish	Volt.
<b>0413</b> Fost Pendant ø80 28W	<b>927</b> 2700K CRI90	<b>1</b> 18°	<b>1</b> White	<b>-110</b> 110V <b>D</b> <b>C</b> <b>ON/OFF</b>
	<b>930</b> 3000K CRI90	<b>2</b> 23°	<b>2</b> Black	
	<b>940</b> 4000K CRI90	<b>3</b> 38°		
	<b>X27</b> 2700K CRI97			
	<b>X30</b> 3000K CRI97			
	<b>X40</b> 4000K CRI97			

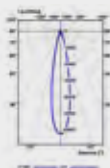

18°

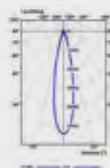

23°



38°

Option	Color T°	CRI	Power	Lumen Output	Beam Angle
927	2700K	90	28W	1684lm / 1772lm / 1334lm	18° / 23° / 38°
X27		97	28W	1515lm / 1595lm / 1200lm	18° / 23° / 38°
930	3000K	90	28W	1736lm / 1827lm / 1375lm	18° / 23° / 38°
X30		97	28W	1562lm / 1644lm / 1237m	18° / 23° / 38°
940	4000K	90	28W	1788lm / 1882lm / 1416lm	18° / 23° / 38°
X40		97	28W	1609lm / 1693lm / 1274lm	18° / 23° / 38°







S Y S T E M S

CONFIGURE YOUR

# NESO

Also for your mobile phone  
También para tu teléfono móvil

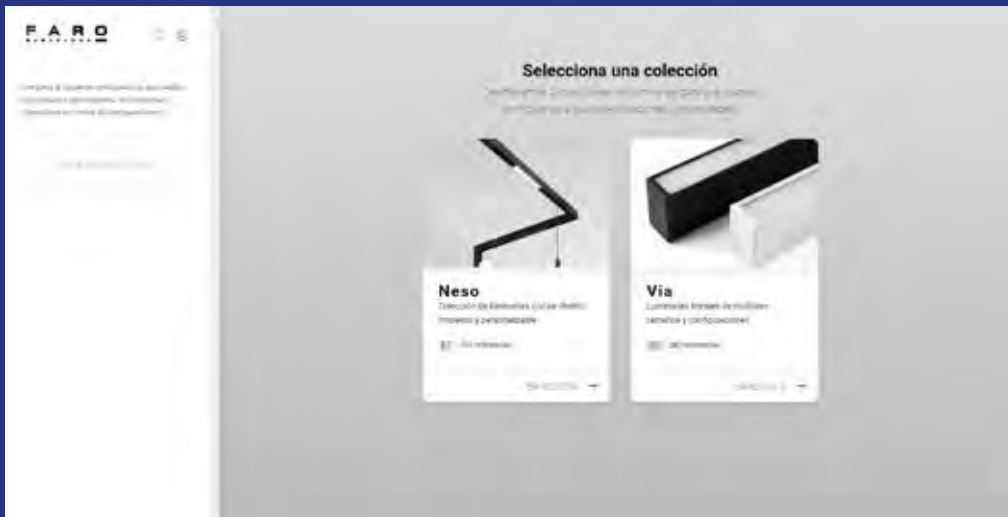

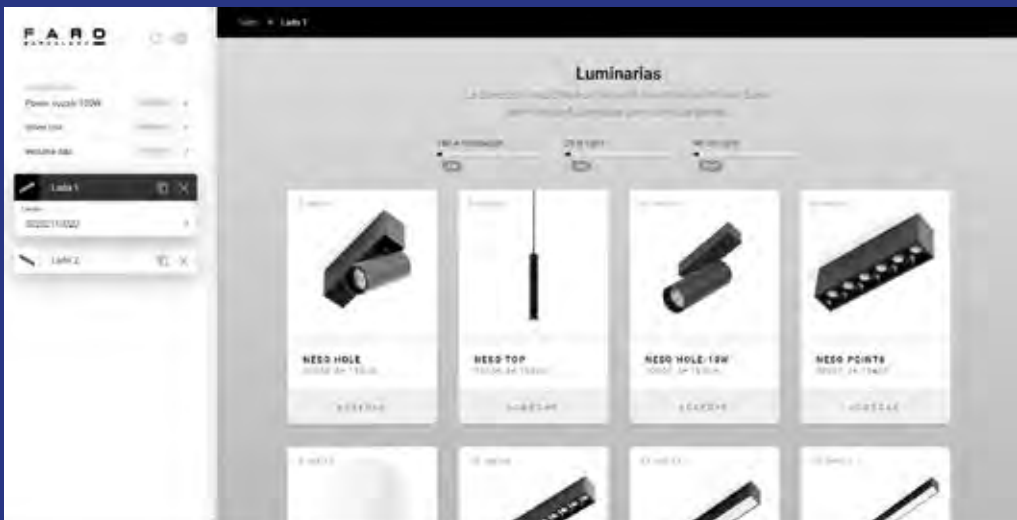
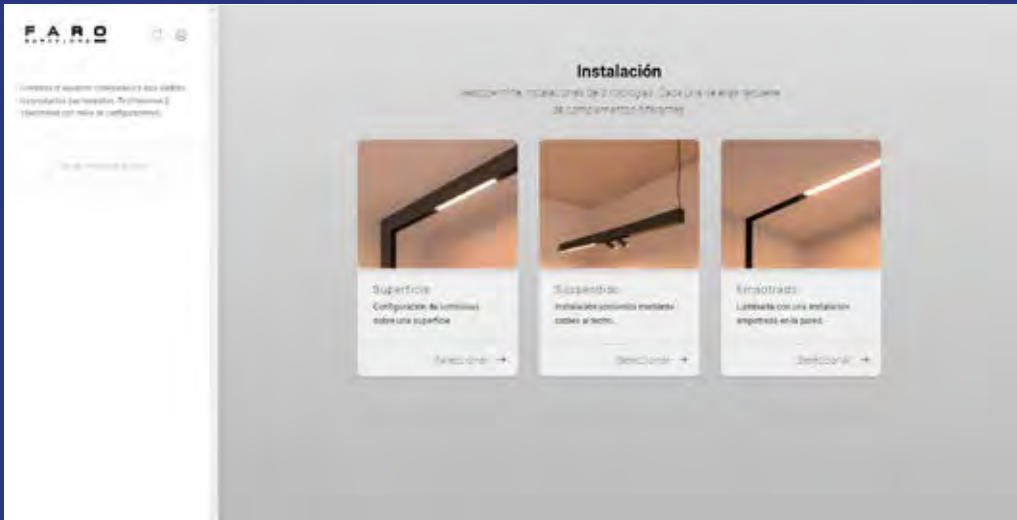

NESO, a magnetic track system, seamlessly integrates various luminaires, ranging from general lights to striking accents. Its modular and magnetic design not only provides flexibility but also transforms environments with its exceptional adaptability and design. Ideal for commercial settings, NESO offers projectors with up to 20W, whereas NESO Slim, tailored for residential spaces, brings elegance and an endless array of options to craft truly unique atmospheres.

NESO, un sistema de carril magnético, fusiona distintas luminarias, abarcando desde luces generales hasta resaltantes acentos. Su diseño modular y magnético no solo brinda flexibilidad, sino que también transforma entornos con su adaptabilidad y diseño excepcional. Perfecto para entornos comerciales, NESO ofrece proyectores de hasta 20W, mientras que NESO Slim, diseñado para espacios residenciales, aporta elegancia y una variedad ilimitada de opciones para crear ambientes verdaderamente únicos.





# THE MAGNETIC TRACK SYSTEM

# NESO



# Highlights

## Neso Slim



**Super Slim design**  
Diseño Super Slim



**Maximum integration of luminaires on rail**  
Integración máxima de las luminarias en carril

## Neso Slim and Standard

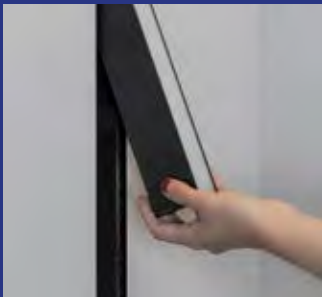

**Magnetic**  
Magnético

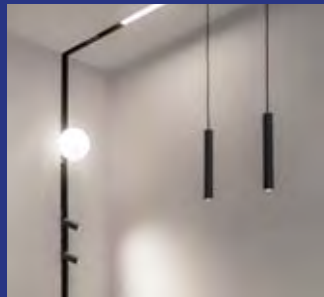

**Versatility**  
Versatilidad

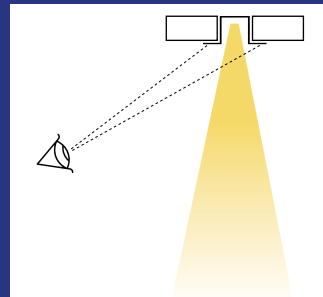

**UGR<16 Option**



**Connectivity**  
Conectividad





# NESO



**TRACKS**  
Carriles

**RECESSED**  
Empotrable



1000 | 2000

**SURFACE**  
Superficie

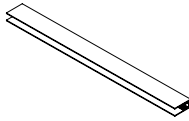

1000 | 2000

**PENDANT**  
Colgante

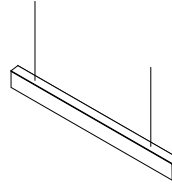

1000 | 2000

**MODULES**  
Módulos

**Neso**  
Point



84



164



320

**Neso**  
Unik



ø150

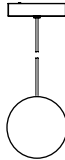

ø150

**Neso**  
Line

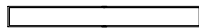

320

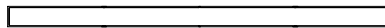

640

**Neso**  
Hole

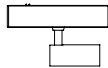

ø35

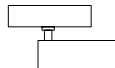

ø50

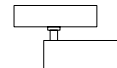

ø70

**Neso**  
Top

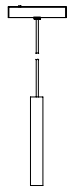

ø35

**FINISH**  
Acabado

● **Black**  
Negro

○ **White**  
Blanco

**COLOR TEMPERATURE**  
Temperatura de color

2700K CRI>90

3000K CRI>90

**CONTROL SYSTEM**  
Sistema de Control



CASAMBI





Thanks to Detail Studio | Photo by Julien Chamoux Photographie

Need consulting  
for your project?  
¿Necesitas  
asesoramiento  
para tu proyecto?





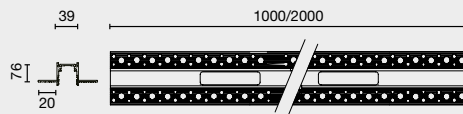
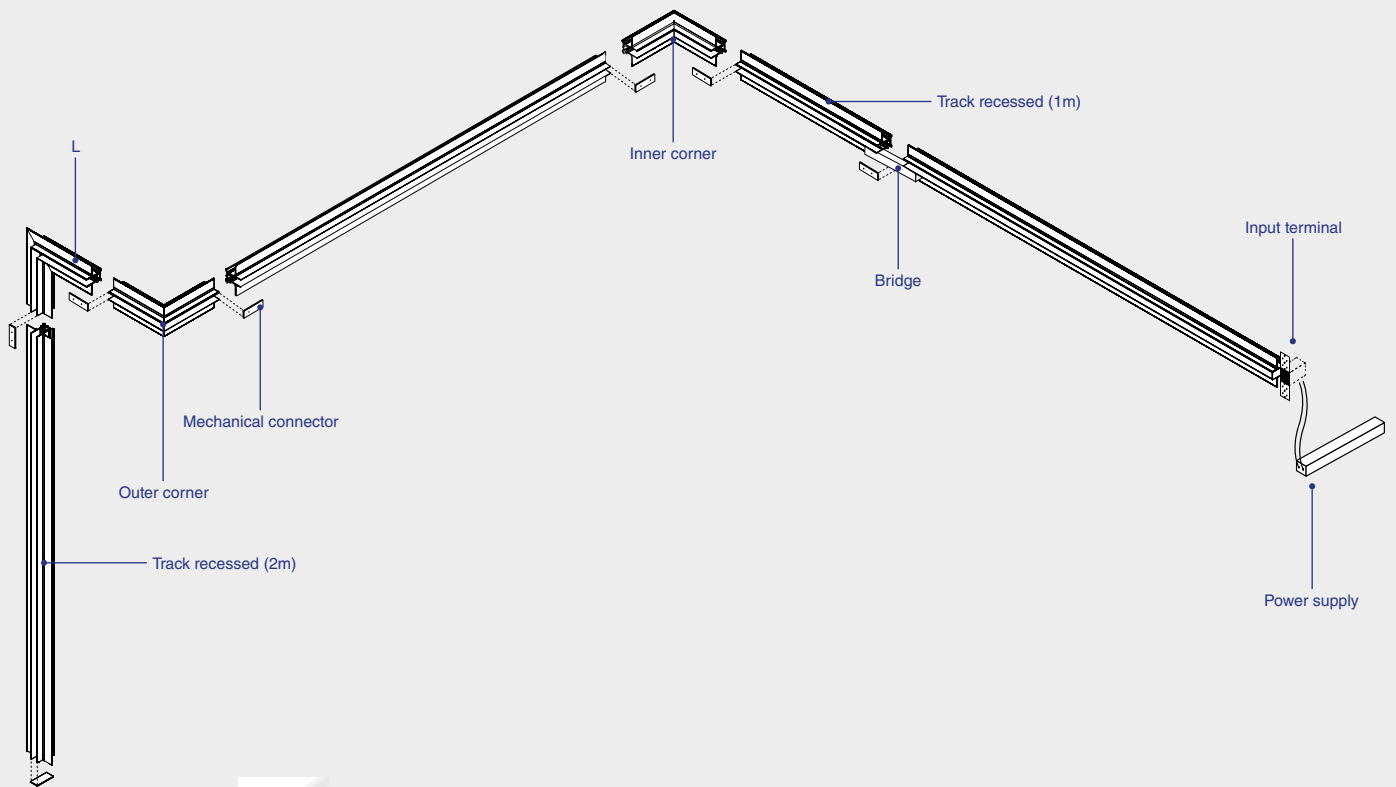

# TRACK RECESSED



III 24V

Family	Track Length	Finish	Control System
5020120 Neso Track Recessed	10 1m	1 White	D  DALI
	20 2m	2 Black	ON/OFF

## ACCESSORIES

	● 5020200102 Mechanical connector
	● 5020115101 / ● 5020115102 Bridge
	● 5020115101D / ● 5020115102D Bridge DALI
	● 5020R120102 Track cover
<b>POWER SUPPLY</b>	
98324200	Power supply 200W

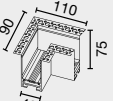
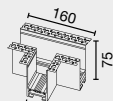
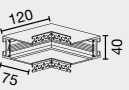
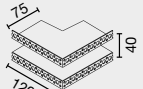
	● 5020221401 / ● 5020221402 Input terminal
	● 5020221401D / ● 5020221402D Input terminal DALI
	● 5020221001 / ● 5020221002 L
	● 5020221001D / ● 5020221002D L DALI
	● 5020221101 / ● 5020221102 T
	● 5020221101D / ● 5020221102D T DALI
	● 5020221201 / ● 5020221202 Inner corner
	● 5020221201D / ● 5020221202D Inner corner DALI
	● 5020221301 / ● 5020221302 Outer corner
	● 5020221301D / ● 5020221302D Outer corner DALI

# TRACK SURFACE & SUSPENSION

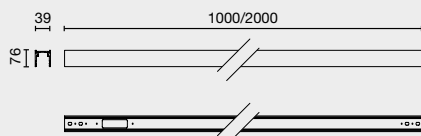
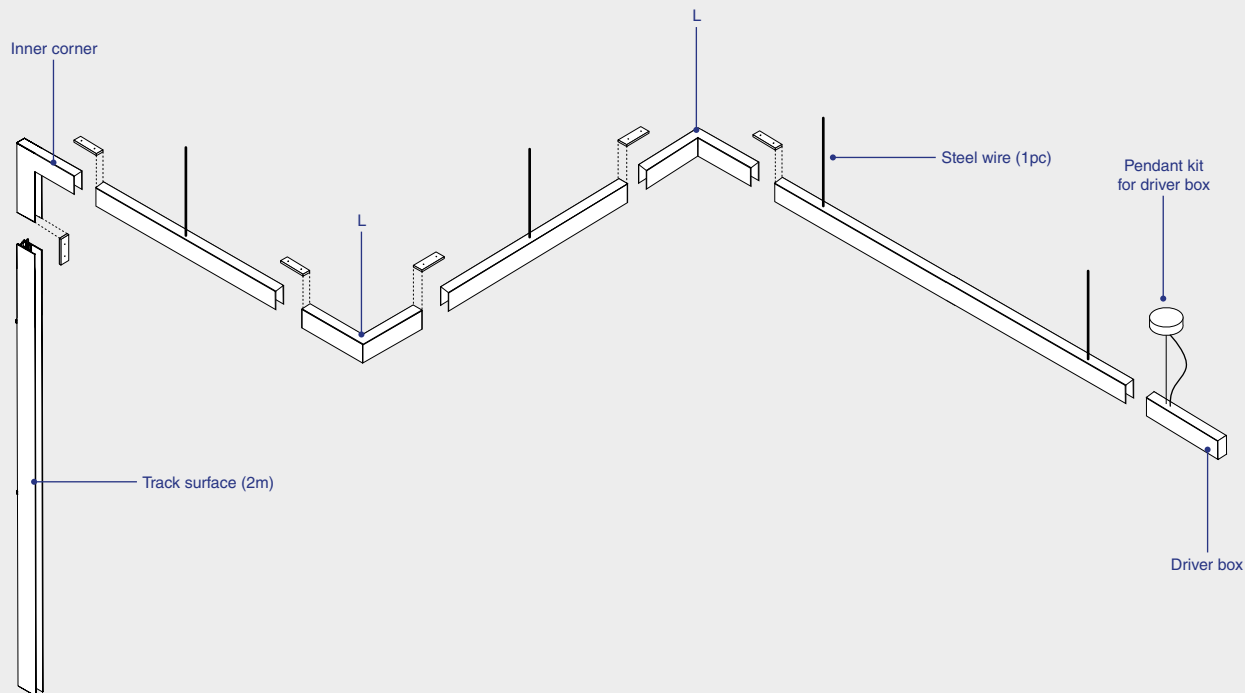

24V

Family	Track Length	Finish	Control System
5020110 Neso Track Surface	10 1m	1 White	D  DALI
	20 2m	2 Black	ON/OFF

## ACCESSORIES

	● 5020200102 Mechanical connector
	● 5020115101 / ● 5020115102 Bridge
	● 5020115101D / ● 5020115102D Bridge DALI
	● 5020210001 / ● 5020210002 Driver box
	● 5020210001D / ● 5020210002D Driver box DALI
	● 5020210201 / ● 5020210202 Pendant kit
	● 5020210201D / ● 5020210202D Pendant kit DALI
	5020210102 Steel wire
	● 5020R120102 Track cover
<b>POWER SUPPLY</b>	
	98324200 Power supply 200W

	● 5020210301 / ● 5020210302 Input terminal
	● 5020210301D / ● 5020210302D Input terminal DALI
	● 5020211001 / ● 5020211002 L
	● 5020211001D / ● 5020211002D L DALI
	● 5020211101 / ● 5020211102 T
	● 5020211101D / ● 5020211102D T DALI
	● 5020211201 / ● 5020211202 Inner corner
	● 5020211201D / ● 5020211202D Inner corner DALI
	● 5020211301 / ● 5020211302 Outer corner
	● 5020211301D / ● 5020211302D Outer corner DALI



## NESO POINT 3L

no incl. 50.000hs L70/B10  MacAdam 3 24V  650°C  UGR <16

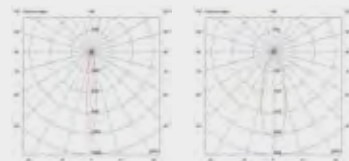
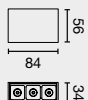

12°

34°

Family	Color T°	Beam Angle	Finish
50101 Point 3L 4W	927 2700K 217lm CRI>90	1 12°	1 White
	930 3000K 292lm CRI>90	2 34°	2 Black

## NESO POINT 6L

no incl. 50.000hs L70/B10  MacAdam 3 24V  650°C  UGR <16

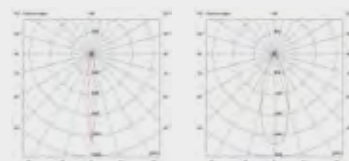
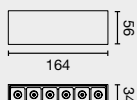

12°

34°

Family	Color T°	Beam Angle	Finish	Control System
50102 Point 6L 8W	927 2700K 480lm CRI>90	1 12°	1 White	W CASAMBI
	930 3000K 506lm CRI>90	2 34°	2 Black	D BALI
				ON/OFF

## NESO POINT 12L

no incl. 50.000hs L70/B10  MacAdam 3 24V  650°C  UGR <16

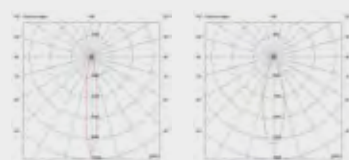

12°

34°

Family	Color T°	Beam Angle	Finish	Control System
50103 Point 12L 16W	927 2700K 1102lm CRI>90	1 12°	1 White	W CASAMBI
	930 3000K 1107lm CRI>90	2 34°	2 Black	D BALI
				ON/OFF





## NESO LINE 32cm

no incl. 50.000hs L70/B10   MacAdam 3 24V  650°C

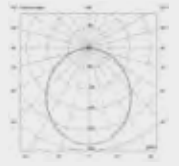
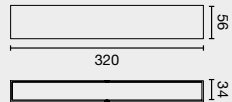

32

### Family

### Color T°

### Finish

### Control System

**50104** Line 32cm 13W

**927** 2700K 892lm CRI>90

**01** White

**W** CASAMBI

**930** 3000K 920lm CRI>90

**02** Black

**D** DALI

ON/OFF

## NESO LINE 64cm

no incl. 50.000hs L70/B10   MacAdam 3 24V  650°C

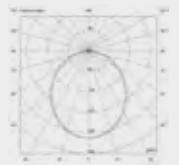
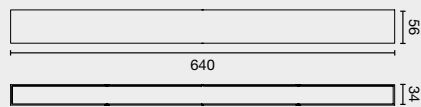

64

### Family

### Color T°

### Finish

### Control System

**50105** Line 64cm 26W

**927** 2700K 1399lm CRI>90

**01** White

**W** CASAMBI

**930** 3000K 1442lm CRI>90

**02** Black

**D** DALI

ON/OFF



## NESO HOLE ø3.5cm

no incl. 50.000hs L70/B10 MacAdam 3 24V 650°C

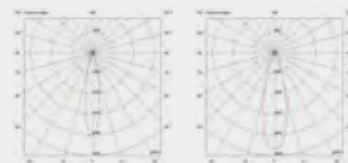
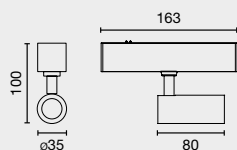

20°

40°

### Family

### Color T°

### Beam Angle

### Finish

### Control System

50107 Hole ø3,5cm 5W

927 2700K 360lm CRI>90

1 20°

1 White

W CASAMBI

930 3000K 444lm CRI>90

2 40°

2 Black

D DALI

ON/OFF

## NESO HOLE ø5cm

no incl. 50.000hs L70/B10 MacAdam 3 24V 650°C

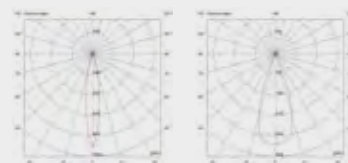
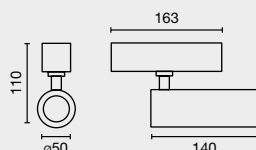

18°

36°

### Family

### Color T°

### Beam Angle

### Finish

### Control System

50108 Hole ø5cm 10W

027 2700K 445lm CRI>90

1 18°

1 White

W CASAMBI

030 3000K 592lm CRI>90

2 36°

2 Black

D DALI

ON/OFF

## NESO HOLE ø7cm

no incl. 50.000hs L70/B10 MacAdam 3 24V 650°C

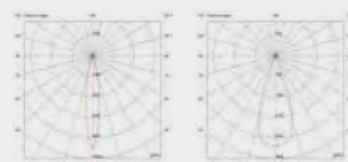
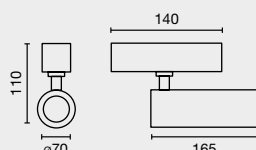

18°

36°

### Family

### Color T°

### Beam Angle

### Finish

### Control System

50110 Hole ø7cm 20W

027 2700K 881lm CRI90

1 18°

1 White

W CASAMBI

030 3000K 1171lm CRI90

2 36°

2 Black

D DALI

ON/OFF





# NESO UNIK

no incl. 50.000hs L70/B10 MacAdam 3 24V 650°C

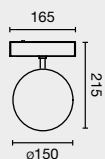

325°

## Family

## Color T°

## Finish

## Control System

50108 Unik 5W

927 2700K 256lm CRI>90

01 White

W CASAMBI

930 3000K 264lm CRI>90

02 Black

D BALI

ON/OFF

# NESO UNIK

no incl. 50.000hs L70/B10 MacAdam 3 24V 650°C

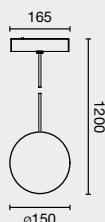

325°

## Family

## Color T°

## Finish

## Control System

50109 Unik 5W

027 2700K 256lm CRI>90

01 White

W CASAMBI

030 3000K 264lm CRI>90

02 Black

D BALI

ON/OFF

# NESO TOP

no incl. 50.000hs L70/B10 MacAdam 3 24V 650°C

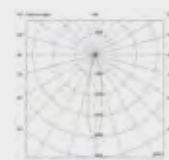
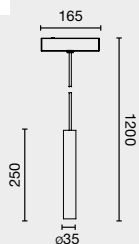

20°

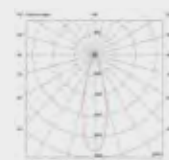

40°

## Family

## Color T°

## Beam Angle

## Finish

## Control System

50106 Top 5W

927 2700K 360m CRI>90

1 20°

1 White

W CASAMBI

930 3000K 444lm CRI>90

2 40°

2 Black

D BALI

ON/OFF



# NESO SLIM



**TRACKS**  
Carriles

**RECESSED**  
Empotrable

**SURFACE**  
Superficie

**PENDANT**  
Colgante

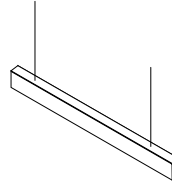
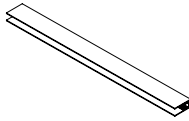

1000 | 2000

1000 | 2000

1000 | 2000

**MODULES**  
Módulos

**Neso Slim**  
Point

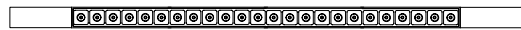
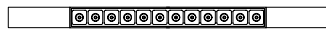

305

388

**Neso Slim**  
Unik

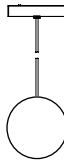

ø150

ø150

**Neso Slim**  
Line

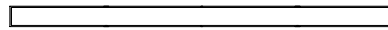
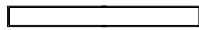

305

704

**Neso Slim**  
Hole

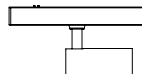
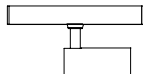

ø35

ø50

**Neso Slim**  
Top

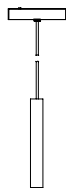

ø35

**FINISH**  
Acabado

● **Black**  
Negro

**COLOR TEMPERATURE**  
Temperatura de color

2700K CRI>90

3000K CRI>90

**CONTROL SYSTEM**  
Sistema de Control



# TRACK RECESSED

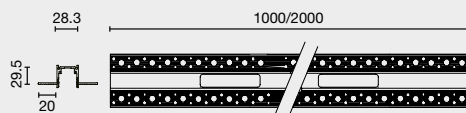
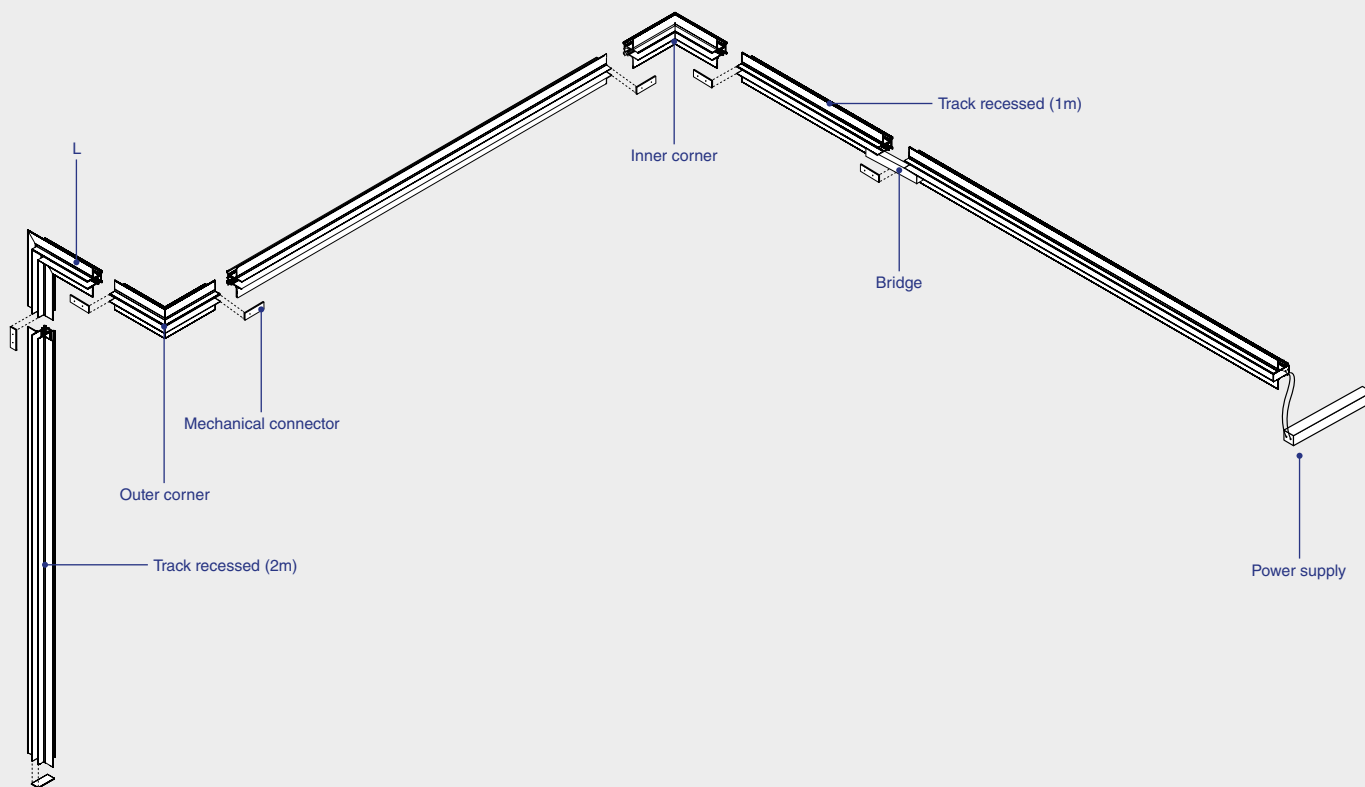

24V

Family	Track Length	Finish	Control System
6020120 Neso Track Recessed	10 1m	2 Black	D  ON/OFF
	20 2m	2	

## ACCESSORIES

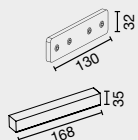

● 6020200102	Mechanical connector
● 6020115102	Bridge
● 6020115102D	Bridge DALI
● 6020R120102	Track cover
<b>POWER SUPPLY</b>	
98324200	Power supply 200W

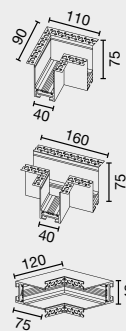

● 6020221002	L
● 6020221002D	L DALI
● 6020221102	T
● 6020221102D	T DALI
● 6020221202	Inner corner
● 6020221202D	Inner corner DALI
● 6020221302	Outer corner
● 6020221302D	Outer corner DALI



# TRACK SURFACE & SUSPENSION

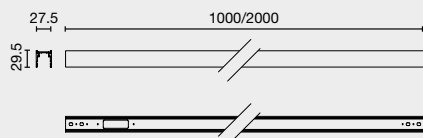
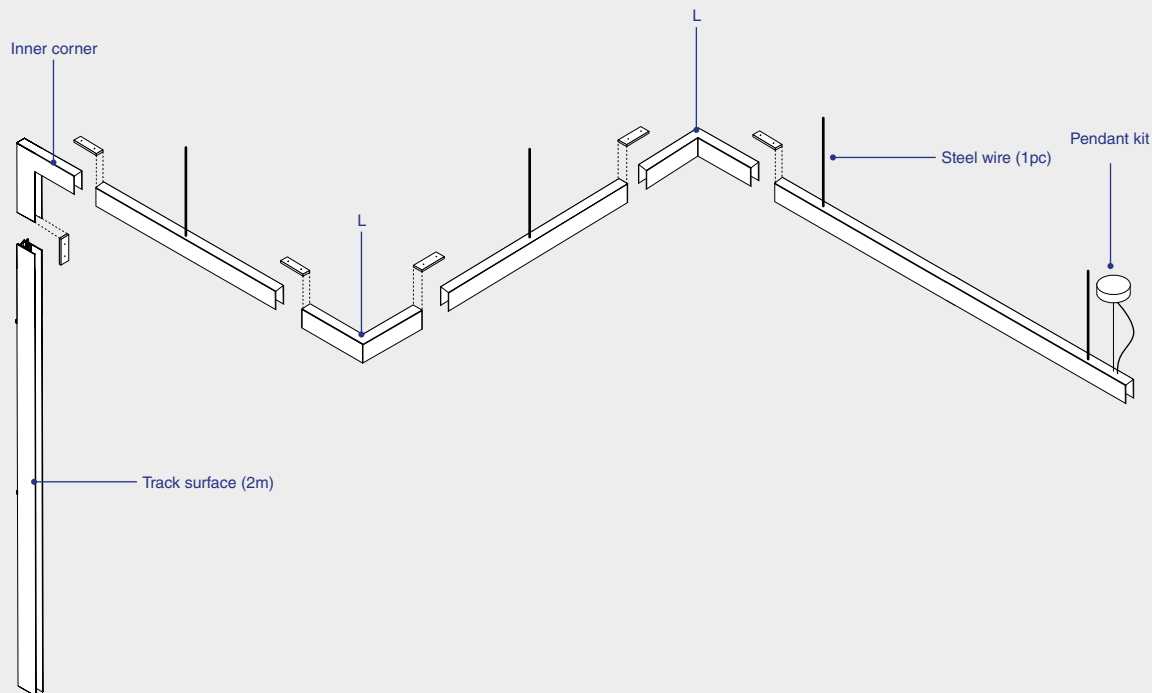

24V

Family	Track Length	Finish	Control System
6020110 Neso Track Surface	10 1m	2 Black	D  ON/OFF
	20 2m	2	

## ACCESSORIES



● 6020200102	Mechanical connector
● 6020200103	Surface mounting Kit
● 6020210202	Pendant Kit
● 6020210202D	Pendant kit DALI
6020210102	Steel wire
6020R120102	Track cover
<b>POWER SUPPLY</b>	
98324200	Power supply 200W

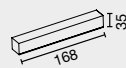

● 6020115102	Bridge
● 6020115102D	Bridge DALI

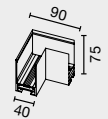

● 6020211002	L
● 6020211002D	L DALI

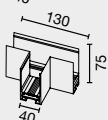

● 6020211102	T
● 6020211102D	T DALI

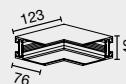

● 6020211202	Inner corner
● 6020211202D	Inner corner DALI

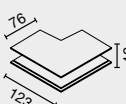



● 6020211302	Outer corner
● 6020211302D	Outer corner DALI

## NESO SLIM POINT 12L

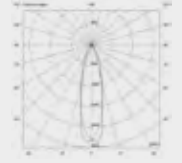
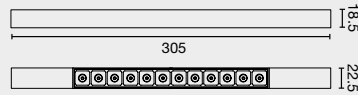
no incl. 50.000hs L70/B10   MacAdam 3 24V  650°C  UGR <16



25°



Family	Color T°	Beam Angle	Finish	Control System						
<b>60102</b> Point slim 12L 12W	<b>927</b> 2700K 816lm CRI>90 <b>930</b> 3000K 841lm CRI>90	<b>1</b> 25°	<b>2</b> Black	<table border="1"> <tr> <td>W</td> <td>CASAMBI</td> </tr> <tr> <td>D</td> <td></td> </tr> <tr> <td></td> <td>ON/OFF</td> </tr> </table>	W	CASAMBI	D			ON/OFF
W	CASAMBI									
D										
	ON/OFF									

## NESO SLIM POINT 24L

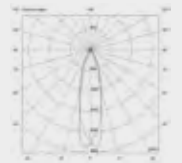
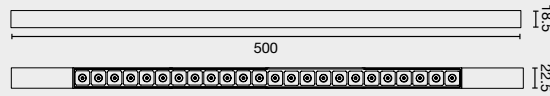
no incl. 50.000hs L70/B10   MacAdam 3 24V  650°C  UGR <16



25°

Family	Color T°	Beam Angle	Finish	Control System						
<b>60103</b> Point slim 24L 24W	<b>927</b> 2700K 1674lm CRI>90 <b>930</b> 3000K 1726lm CRI>90	<b>1</b> 25°	<b>2</b> Black	<table border="1"> <tr> <td>W</td> <td>CASAMBI</td> </tr> <tr> <td>D</td> <td></td> </tr> <tr> <td></td> <td>ON/OFF</td> </tr> </table>	W	CASAMBI	D			ON/OFF
W	CASAMBI									
D										
	ON/OFF									



## NESO SLIM LINE 30cm

no incl. 50.000hs L70/B10   MacAdam 3 24V  650°C

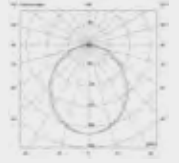
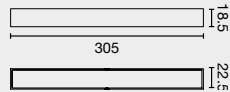

Family	Color T°	Finish	Control System						
<b>60104</b> Line slim 30cm 6W	<b>927</b> 2700K 322lm CRI>90 <b>930</b> 3000K 332lm CRI>90	<b>02</b> Black	<table border="1"> <tr> <td>W</td> <td>CASAMBI</td> </tr> <tr> <td>D</td> <td></td> </tr> <tr> <td></td> <td>ON/OFF</td> </tr> </table>	W	CASAMBI	D			ON/OFF
W	CASAMBI								
D									
	ON/OFF								

## NESO SLIM LINE 70cm

no incl. 50.000hs L70/B10   MacAdam 3 24V  650°C

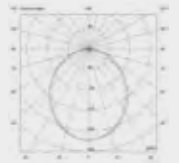
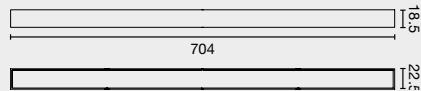

Family	Color T°	Finish	Control System						
<b>60105</b> Line slim 70cm 18W	<b>927</b> 2700K 875lm CRI>90 <b>930</b> 3000K 902lm CRI>90	<b>02</b> Black	<table border="1"> <tr> <td>W</td> <td>CASAMBI</td> </tr> <tr> <td>D</td> <td></td> </tr> <tr> <td></td> <td>ON/OFF</td> </tr> </table>	W	CASAMBI	D			ON/OFF
W	CASAMBI								
D									
	ON/OFF								





## NESO SLIM HOLE ø3.5cm

no incl. 50.000hs L70/B10  MacAdam 3 24V  650°C

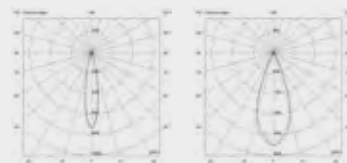
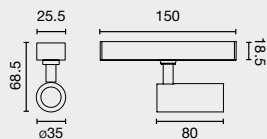

20°

40°

Family	Color T°	Beam Angle	Finish	Control System
--------	----------	------------	--------	----------------

**60107** Hole slim ø3,5cm 5W

<b>927</b>	2700K 337lm CRI>90	<b>1</b> 20°
<b>930</b>	3000K 344lm CRI>90	<b>2</b> 40°

**2** Black

W	CASAMBI
D	DALI
	ON/OFF

## NESO SLIM HOLE ø5cm

no incl. 50.000hs L70/B10  MacAdam 3 24V  650°C

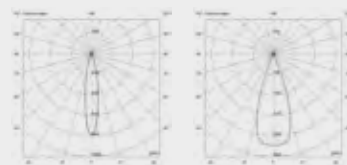
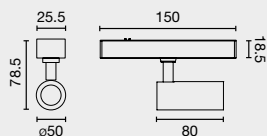

18°

36°

Family	Color T°	Beam Angle	Finish	Control System
--------	----------	------------	--------	----------------

**60108** Hole slim ø5cm 10W

<b>027</b>	2700K 445lm CRI>90	<b>1</b> 18°
<b>030</b>	3000K 592lm CRI>90	<b>2</b> 36°

**2** Black

W	CASAMBI
D	DALI
	ON/OFF



## NESO SLIM UNIK

no incl. 50.000hs L70/B10 MacAdam 3 24V 650°C

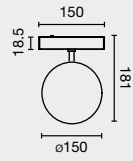

325°

**Family** **Color T°** **Finish** **Control System**

60108 Unik slim 5W

927 2700K 230lm CRI>90

02 Black

W CASAMBI

D DALI

ON/OFF

930 3000K 237lm CRI>90

## NESO SLIM UNIK PENDANT

no incl. 50.000hs L70/B10 MacAdam 3 24V 650°C

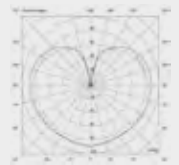
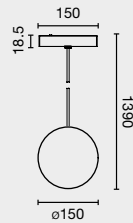

325°

**Family** **Color T°** **Finish** **Control System**

60109 Unik slim pendant 5W

027 2700K 230lm CRI>90

02 Black

W CASAMBI

D DALI

ON/OFF

030 3000K 237lm CRI>90

## NESO SLIM TOP

no incl. 50.000hs L70/B10 MacAdam 3 24V 650°C

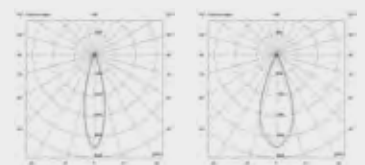
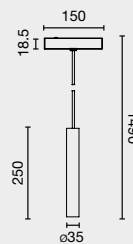

20°

40°

**Family** **Color T°** **Beam Angle** **Finish** **Control System**

60106 Top slim top 5W

927 2700K 308lm CRI>90

1 20°

2 Black

W CASAMBI

D DALI

ON/OFF

930 3000K 320lm CRI>90

2 40°



## NESO POINT 3L

Option	Color T°	CRI	Power	Lumen Output	Beam Angle
927	2700k	90	4W	217lm / 221lm	12° / 34°
930	3000k	90	4W	292lm / 298lm	12° / 34°

## NESO POINT 6L

Option	Color T°	CRI	Power	Lumen Output	Beam Angle
927	2700k	90	8W	480lm / 487lm	12° / 34°
930	3000k	90	8W	506lm / 512lm	12° / 34°

## NESO POINT 12L

Option	Color T°	CRI	Power	Lumen Output	Beam Angle
927	2700k	90	8W	1102lm / 1109lm	12° / 34°
930	3000k	90	8W	1107lm / 1112lm	12° / 34°

## NESO LINE 32cm

Option	Color T°	CRI	Power	Lumen Output	Beam Angle
927	2700k	90	6W	892lm	100°
930	3000k	90	6W	920lm	100°

## NESO LINE 64cm

Option	Color T°	CRI	Power	Lumen Output	Beam Angle
927	2700k	90	18W	1399lm	100°
930	3000k	90	18W	1442lm	100°

## NESO HOLE ø3.5cm

Option	Color T°	CRI	Power	Lumen Output	Beam Angle
927	2700k	90	5W	360lm / 372lm	20° / 40°
930	3000k	90	5W	592lm / 602lm	20° / 40°

## NESO HOLE ø5cm

Option	Color T°	CRI	Power	Lumen Output	Beam Angle
927	2700k	90	10W	825lm / 932lm	18° / 36°
930	3000k	90	10W	954lm / 961lm	18° / 36°

## NESO HOLE ø7cm

Option	Color T°	CRI	Power	Lumen Output	Beam Angle
927	2700k	90	20W	881lm / 1136lm	18° / 36°
930	3000k	90	20W	908lm / 1171lm	18° / 36°

## NESO UNIK

Option	Color T°	CRI	Power	Lumen Output	Beam Angle
927	2700k	90	5W	256lm	325°
930	3000k	90	5W	264lm	325°

## NESO TOP

Option	Color T°	CRI	Power	Lumen Output	Beam Angle
927	2700k	90	5W	360 / 371lm	20° / 40°
930	3000k	90	5W	444 / 452lm	20° / 40°



## NESO SLIM POINT 12L

Option	Color T°	CRI	Power	Lumen Output	Beam Angle
927	2700k	90	12W	816lm	25°
930	3000k	90	12W	841lm	25°

## NESO SLIM POINT 24L

Option	Color T°	CRI	Power	Lumen Output	Beam Angle
927	2700k	90	24W	1674lm	25°
930	3000k	90	24W	1726lm	25°

## NESO SLIM LINE 30cm

Option	Color T°	CRI	Power	Lumen Output	Beam Angle
927	2700k	90	6W	322lm	100°
930	3000k	90	6W	332lm	100°

## NESO SLIM LINE 70cm

Option	Color T°	CRI	Power	Lumen Output	Beam Angle
927	2700k	90	18W	875lm	100°
930	3000k	90	18W	902lm	100°

## NESO SLIM HOLE ø3.5cm

Option	Color T°	CRI	Power	Lumen Output	Beam Angle
927	2700k	90	5W	334lm / 334lm	20° / 40°
930	3000k	90	5W	347lm / 344lm	20° / 40°

## NESO SLIM HOLE ø5cm

Option	Color T°	CRI	Power	Lumen Output	Beam Angle
927	2700k	90	10W	545lm / 572lm	18° / 36°
930	3000k	90	10W	562lm / 590lm	18° / 36°

## NESO SLIM UNIK

Option	Color T°	CRI	Power	Lumen Output	Beam Angle
927	2700k	90	5W	230lm	325°
930	3000k	90	5W	237lm	325°

## NESO SLIM TOP

Option	Color T°	CRI	Power	Lumen Output	Beam Angle
927	2700k	90	5W	308 / 310lm	20° / 40°
930	3000k	90	5W	318 / 320lm	20° / 40°

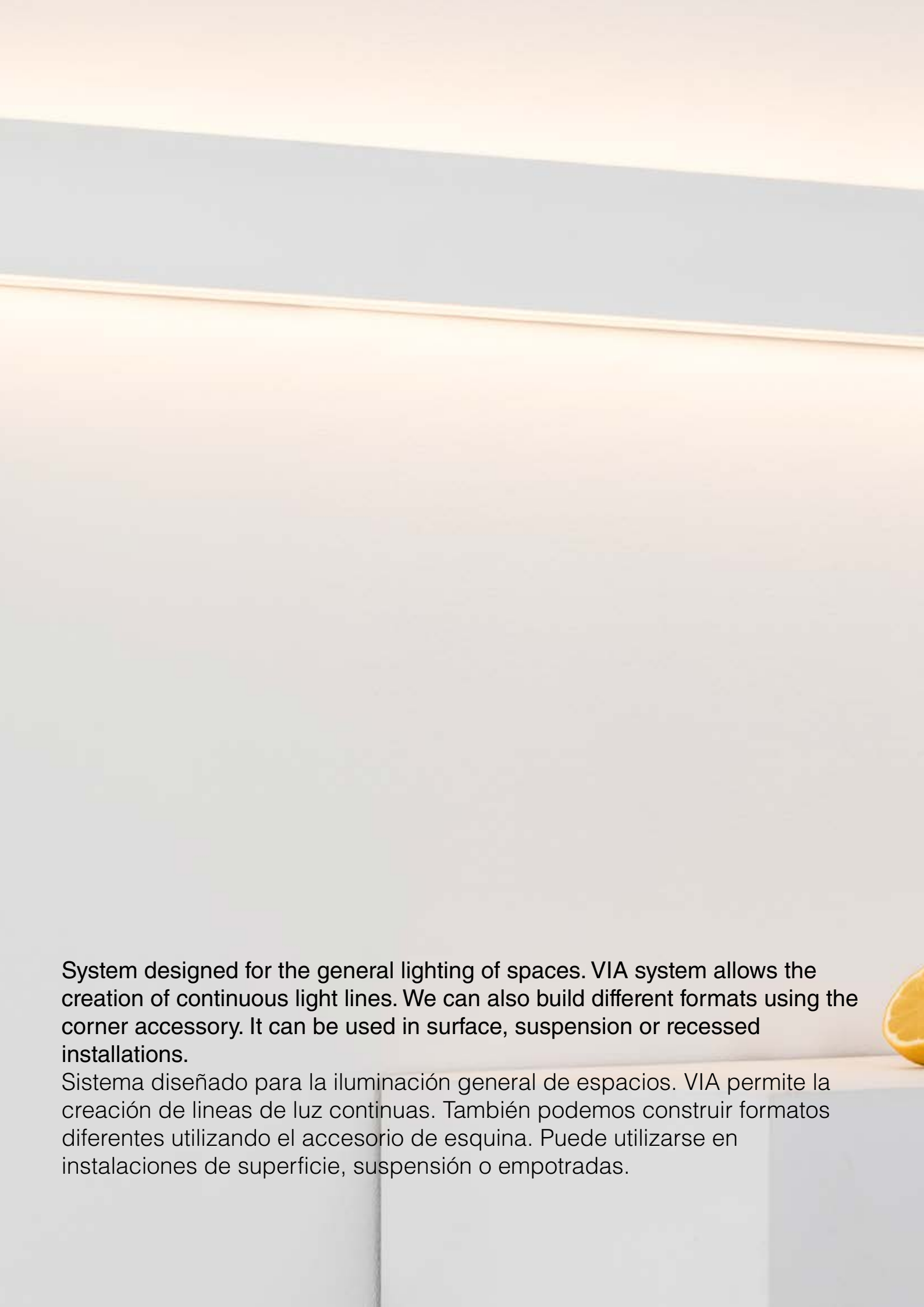

System designed for the general lighting of spaces. VIA system allows the creation of continuous light lines. We can also build different formats using the corner accessory. It can be used in surface, suspension or recessed installations.

Sistema diseñado para la iluminación general de espacios. VIA permite la creación de líneas de luz continuas. También podemos construir formatos diferentes utilizando el accesorio de esquina. Puede utilizarse en instalaciones de superficie, suspensión o empotradas.

**WIA**



**E V O L U T I O N**



VIA Collection



Track  
67

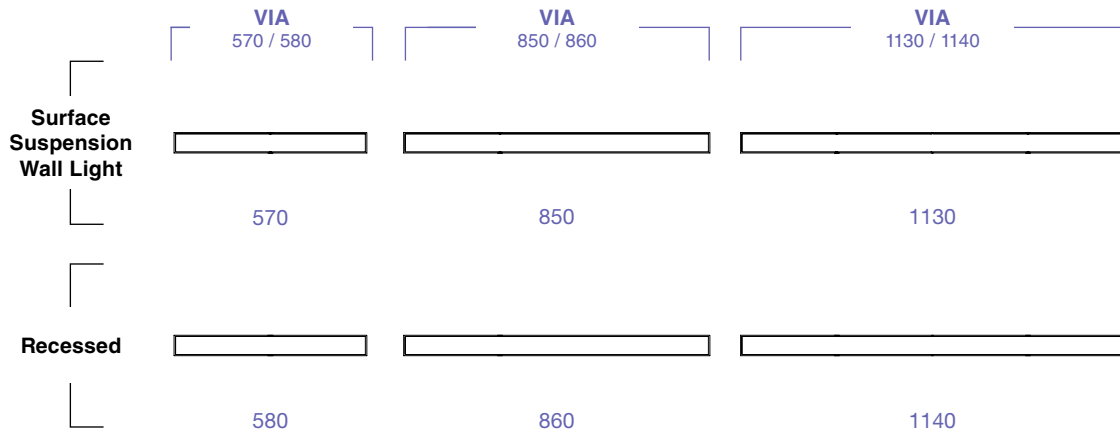

**LIGHT DIRECTION**  
Dirección de la luz

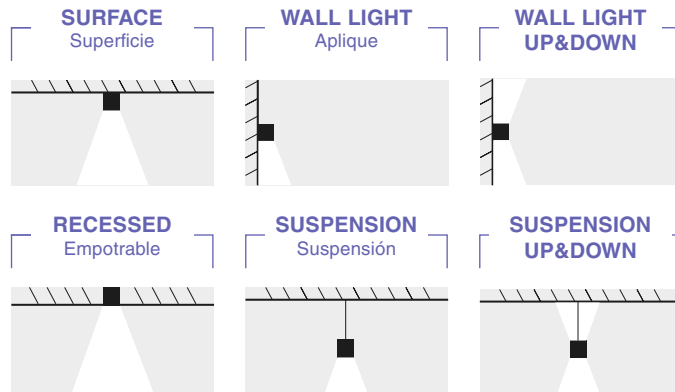

**FINISH**  
Acabado

- Black**  
Negro
- White**  
Blanco

**COLOR TEMPERATURE**  
Temperatura de color

- 3000K CRI80
- 4000K CRI80
- 2700-3000K
- LEAF \*

**DIFFUSER**  
Difusor

- Opal
- Microprisma
- UGR

**CONTROL SYSTEM**  
Sistema de Control



\* Leaf. More information on page 31  
\* Leaf. Más información en la página 31





Surface 570

Surface 850

Surface UGR16 1130

Suspension 570

Suspension 850

Suspension 1130

Wall Light Up & Down 1130

Wall Light 850

Wall Light 570



Suspension  
Up & Down 1130

Suspension UGR 1130

Suspension UGR  
Up & Down 1130

Recessed 580

Recessed 860

Recessed 1140

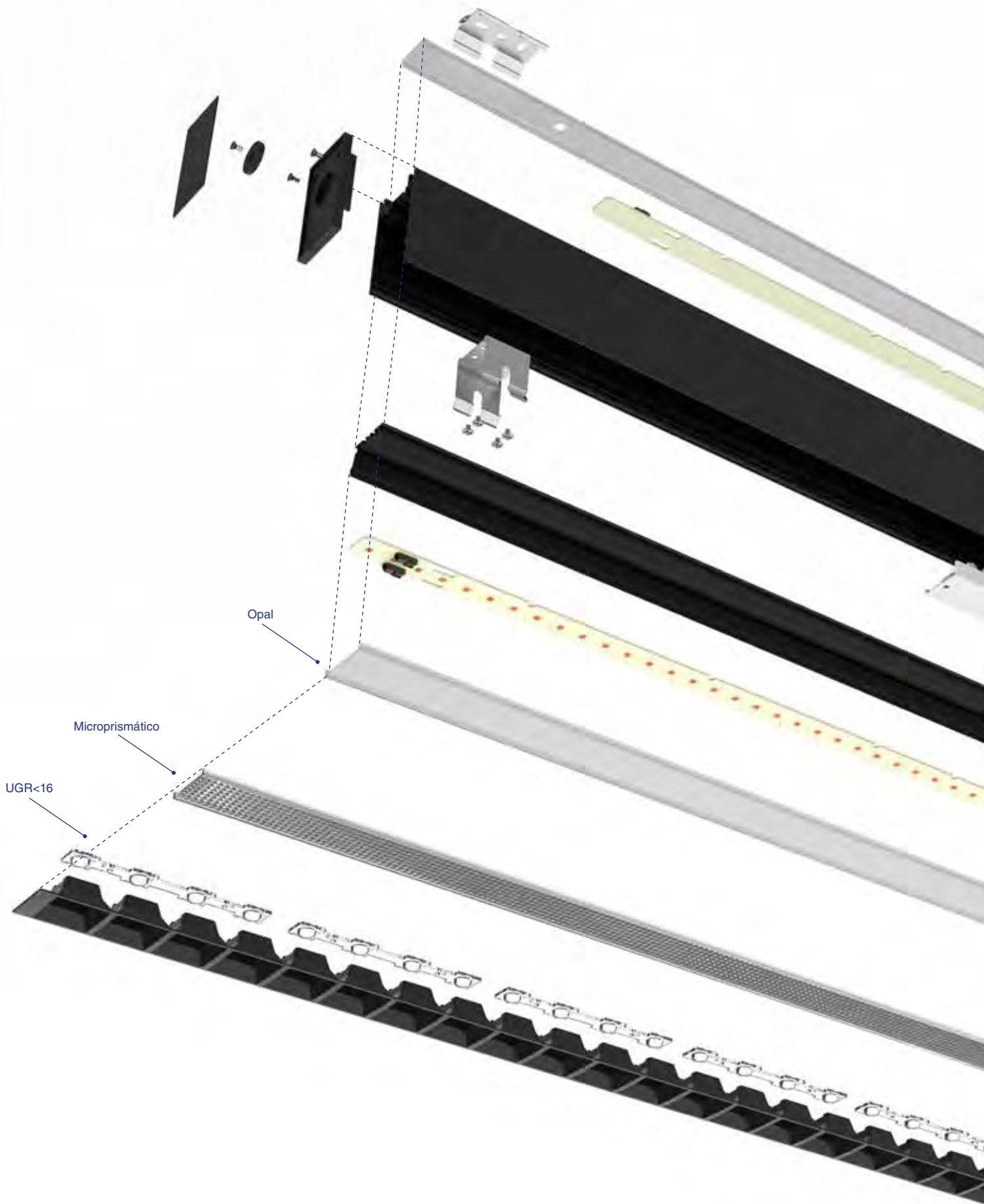

CONFIGURE YOUR

# VIA

Also for your mobile phone  
También para tu teléfono móvil

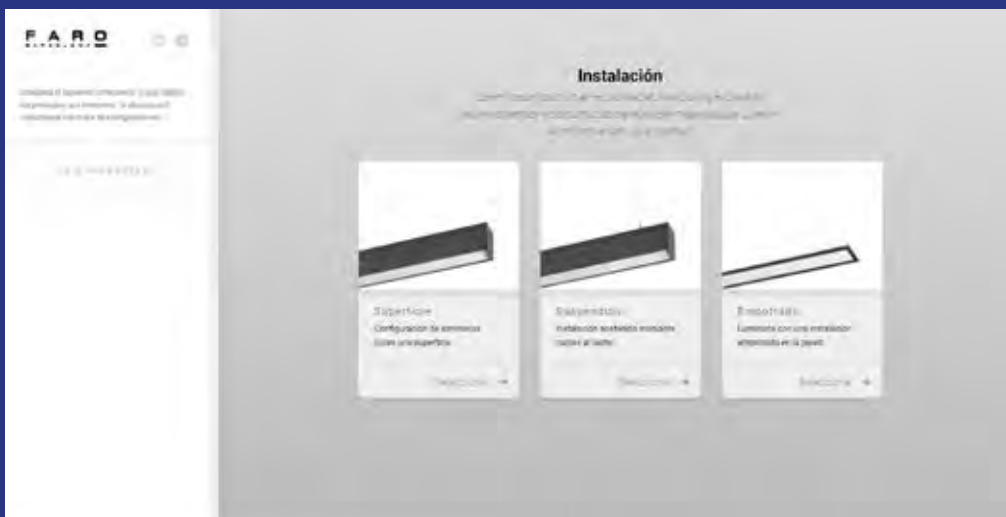
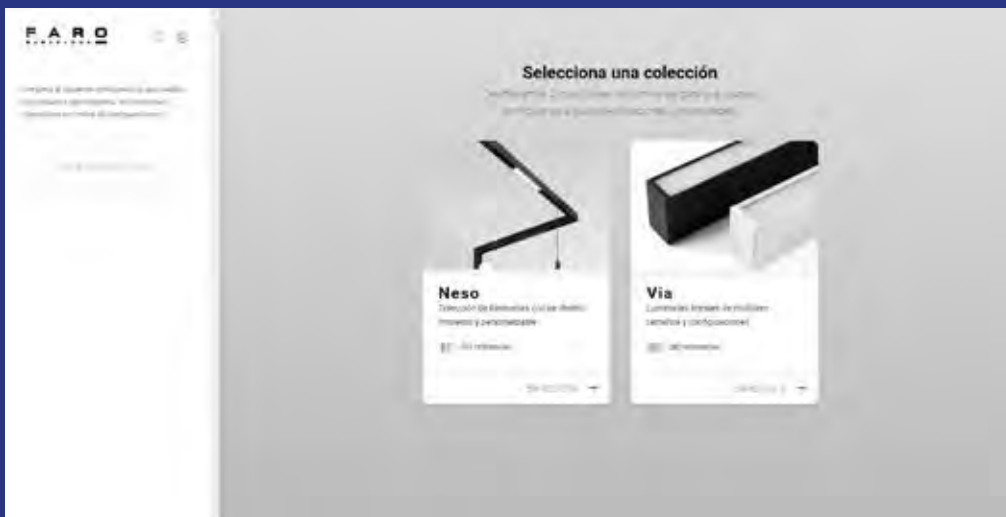





Thanks to SEQURA Headquarters | Interior designer: Mercè Font



Need consulting  
for your project?  
¿Necesitas  
asesoramiento  
para tu proyecto?





Pendant Accessory



Pendant Accessory Dali



Continuous Accessory Surface (1 pcs)



Suspension Wire (2 pcs)



L-Shape without light



End Line Sensor



Middle Line Sensor

# Accessories

	Pendant Accessory	Pendant Accessory Dali	L-Shape Without Light	Continuous Accessory Surface	Suspension Wire	End Line Sensor	Middle Line Sensor
●	040000093	040000095	040000091	040000097	040000098	040000089	040000101
●	040000094	040000096	040000090			040000099	040000100



**Residential**



**Office**



**Microprisma**



**90°**



**Opal**



**110°**



**UGR**



**50°**



**80°**

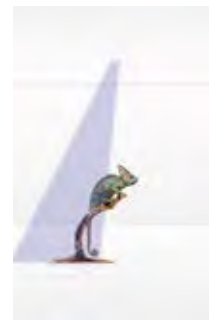

**Asym°**

## VIA SURFACE & SUSPENSION 570

incl. DIM 50.000hs L80/B10 MacAdam 3 110V 50 / 60Hz 650°C

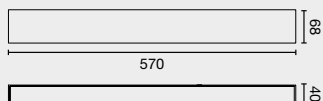

Family	Power	Finish	Control System	Diffuser	Volt.
04100 Via Evo	590	Surface 15W 3000K CRI80	1 White	ON/OFF	Opal
	570	Surface 25W 3000K CRI80	2 Black	D DALI	
	680	Surface 15W 4000K CRI80			
	660	Surface 25W 4000K CRI80			

04100 570 1 D -110

Example [041005701D-110](#) — Via Evo Surface 570 mm 25W 3000K Opal White 110V

## VIA SURFACE & SUSPENSION 850

incl. DIM 50.000hs L80/B10 MacAdam 3 110V 50 / 60Hz 850°C

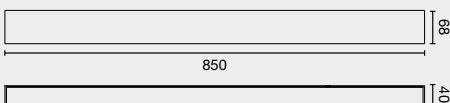

Family	Power	Finish	Control System	Diffuser	Volt.
04100 Via Evo	560	Surface 20W 3000K CRI80	1 White	ON/OFF	Opal
	540	Surface 38W 3000K CRI80	2 Black	D DALI	
	650	Surface 20W 4000K CRI80			
	630	Surface 38W 4000K CRI80			



## VIA SURFACE & SUSPENSION 1130

incl. DIM 50.000hs L80/B10 MacAdam 3 110V 50 / 60Hz 650°C UGR 16

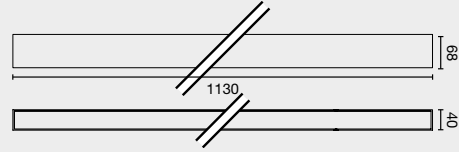

Family	Power	Finish	Control System	Diffuser	Volt.
04100 Via Evo	530	Surface 27W 3000K CRI80	ON/OFF D DALI	Opal	-110 110V
	510	Surface 51W 3000K CRI80		Microprisma	
	620	Surface 27W 4000K CRI80			
	600	Surface 51W 4000K CRI80			

04102 Via Evo	110	Surface UGR 32W 3000K CRI80	ON/OFF D DALI	8 UGR<19 80°	-110 110V
	120	Surface UGR 32W 4000K CRI80		5 UGR<16 50°	
	111	Surface UGR 17W 3000K CRI80		0 UGR<19 asim.	
	121	Surface UGR 17W 4000K CRI80			

## VIA L-SHAPE

incl. DIM 50.000hs L80/B10 MacAdam 3 110V 50 / 60Hz 850°C

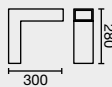

Accessory	Power	Finish	Control System	Diffuser
04100 L-shape	961	3000K 15W	ON/OFF D DALI	Opal
	971	4000K 15W		Microprisma
	981	3000K 25W		
	991	4000K 25W		

Combine different VIA models. See colours to check compatibility of models in "L" installations or continuous lines.

Combina distintos modelos de VIA. Mira los colores para verificar las compatibilidades de modelos en instalaciones en "L" o líneas continuas.





## VIA UP&DOWN 850

\*Always order Suspension Kit  
\*Siempre pedir Kit de suspensión

incl. DIM 50.000hs L80/B10 MacAdam 3 110V 50 / 60Hz 650°C

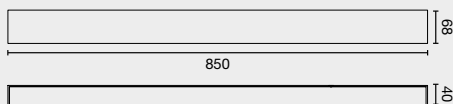

Family	Power	Finish	Control System	Diffuser	Volt.
04200 Via Evo	540	Up&down 14+38W 3000K CRI80	1 White	ON/OFF	-110 110V
	630	Up&down 14+38W 4000K CRI80	2 Black	D DALI U Microprisma	

## VIA UP&DOWN 1130

\*Always order Suspension Kit  
\*Siempre pedir Kit de suspensión

incl. DIM 50.000hs L80/B10 MacAdam 3 110V 50 / 60Hz 650°C

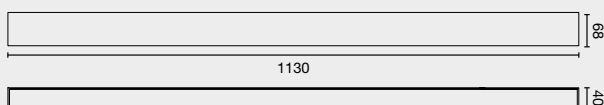

Family	Power	Finish	Control System	Diffuser	Volt.
04200 Via Evo	510	Up&down 21+51W 3000K CRI80	1 White	ON/OFF	-110 110V
	600	Up&down 21+51W 4000K CRI80	2 Black	D DALI U Microprisma	

# VIA UP&DOWN UGR 1130

incl. DIM 50.000hs L80/B10 MacAdam 3 110V 50 / 60Hz 650°C UGR 16

\*Always order Suspension Kit  
\*Siempre pedir Kit de suspensión

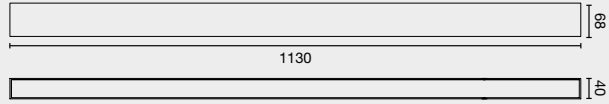

Family	Power	Finish	Control System	Diffuser	Volt.
04202 Via Evo	110	1 White	ON/OFF	Opal	-110 110V
	120	2 Black	D DALI	U Microprisma	

## VIA RECESSED 580

incl. DIM 50.000hs L80/B10 MacAdam 3 110V 50 / 60Hz 650°C



574x50

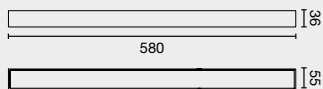

Family	Power	Finish	Control System	Diffuser	Volt.
04100 Via Evo	770	Recessed 15W 3000K CRI80	1 White	ON/OFF	-110 110V
	750	Recessed 25W 3000K CRI80	2 Black	D DALI	
	800	Recessed 15W 4000K CRI80			
	780	Recessed 25W 4000K CRI80			

## VIA RECESSED 860

incl. DIM 50.000hs L80/B10 MacAdam 3 110V 50 / 60Hz 650°C

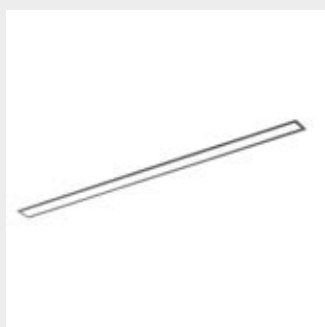

854x50

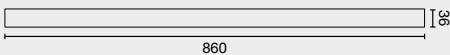

Family	Power	Finish	Control System	Diffuser	Volt.
04100 Via Evo	0830	Recessed 20W 3000K CRI80	1 White	ON/OFF	-110 110V
	0810	Recessed 38W 3000K CRI80	2 Black	D DALI	
	0860	Recessed 20W 4000K CRI80			
	0840	Recessed 38W 4000K CRI80			

# VIA RECESSED 1140

incl. DIM 50.000hs L80/B10 MacAdam 3 110V 50 / 60Hz 650°C



1134x50

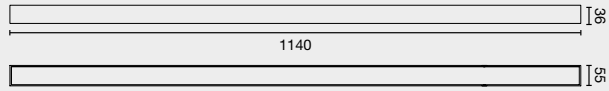

Family	Power	Finish	Control System	Diffuser	Volt.
04100 Via Evo	0890 Recessed 27W 3000K CRI80	1 White	ON/OFF	Opal	-110 110V
	0870 Recessed 51W 3000K CRI80	2 Black	D DALI	U Microprisma	
	0920 Recessed 27W 4000K CRI80				
	0900 Recessed 51W 4000K CRI80				

## VIA WALL LIGHT 570

incl. DIM 50.000hs L80/B10 MacAdam 3 110V 50 / 60Hz 650°C

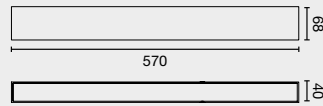

Family	Power	Finish	Control System	Diffuser	Volt.	
04100 Via Evo	595	Wall Light 15W 3000K CRI80	1 White	ON/OFF	Opal	-110 110V
	575	Wall Light 25W 3000K CRI80	2 Black	D DALI	U Microprisma	
	685	Wall Light 15W 4000K CRI80				
	665	Wall Light 25W 4000K CRI80				

## VIA WALL LIGHT 850

incl. DIM 50.000hs L80/B10 MacAdam 3 110V 50 / 60Hz 650°C

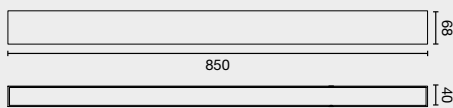

Family	Power	Finish	Control System	Diffuser	Volt.	
04100 Via Evo	565	Wall Light 20W 3000K CRI80	1 White	ON/OFF	Opal	-110 110V
	545	Wall Light 38W 3000K CRI80	2 Black	D DALI	U Microprisma	
	655	Wall Light 20W 4000K CRI80				
	635	Wall Light 38W 4000K CRI80				



# VIA WALL LIGHT 1130

incl. DIM 50.000hs L80/B10 MacAdam 3 110V 50 / 60Hz 650°C

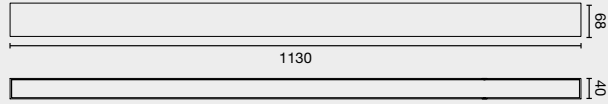

Family	Power	Finish	Control System	Diffuser	Volt.
04100 Via Evo	535 Wall Light 27W 3000K CRI80	1 White	ON/OFF	Opal	-110 110V
	515 Wall Light 51W 3000K CRI80	2 Black	D DALI		
	625 Wall Light 27W 4000K CRI80				
	605 Wall Light 51W 4000K CRI80				
04104 Via Evo	LF Wall Leaf 33W	1 White	D DALI	Opal	
		2 Black		U Microprisma	

## VIA WALL LIGHT UP&DOWN 850

incl. DIM 50.000hs L80/B10 MacAdam 3 110V 50 / 60Hz 650°C

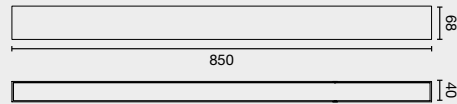

Family	Power	Finish	Control System	Diffuser	Volt.
04200 Via Evo	545	Wall Light Up&Down 14+38W 3000K CRI80	1 White	ON/OFF	Opal -110 110V
	635	Wall Light Up&Down 14+38W 4000K CRI80	2 Black	D	

## VIA WALL LIGHT UP&DOWN 1130

incl. DIM 50.000hs L80/B10 MacAdam 3 110V 50 / 60Hz 650°C

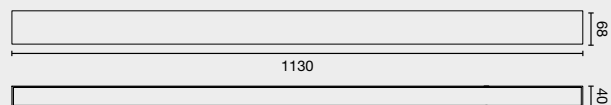

Family	Power	Finish	Control System	Diffuser	Volt.
04200 Via Evo	515	Wall Light Up&Down 21+51W 3000K CRI80	1 White	ON/OFF	Opal -110 110V
	605	Wall Light Up&Down 21+51W 4000K CRI80	2 Black	D	

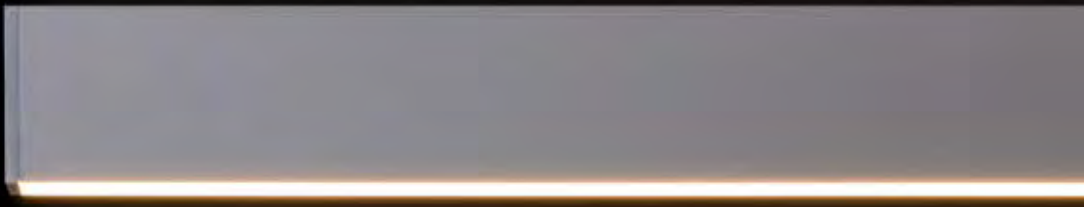

## VIA SURFACE & SUSPENSION

570mm						
Option	Color T°	CRI	Difusor	Power	Lumen Output	Beam Angle
590	3000K	80	Opal / Microprisma	15W	1392lm / 1133lm	110° / 90°
570		80	Opal / Microprisma	25W	2506m / 2039m	110° / 90°
680	4000K	80	Opal / Microprisma	15W	1434lm / 1167lm	110° / 90°
660		80	Opal / Microprisma	25W	2581lm / 2100lm	110° / 90°
850mm						
560	3000K	80	Opal / Microprisma	20W	2131lm / 1735lm	110° / 90°
540		80	Opal / Microprisma	38W	3809lm / 3121lm	110° / 90°
650	4000K	80	Opal / Microprisma	20W	2195lm / 1787lm	110° / 90°
630		80	Opal / Microprisma	39W	3923lm / 3214lm	110° / 90°
1130mm						
530	3000K	80	Opal / Microprisma	27W	2842lm / 2313lm	110° / 90°
510		80	Opal / Microprisma	51W	5112lm / 4161lm	110° / 90°
620	4000K	80	Opal / Microprisma	27W	2927lm / 2382lm	110° / 90°
600		80	Opal / Microprisma	51W	5265lm / 4286lm	110° / 90°
110	3000K	80	UGR<16 / UGR<19	32W	3989lm / 4104lm / 3739lm	50° / 80° / Asym
120	4000K	80	UGR<16 / UGR<19	32W	4109lm / 4227lm / 3851lm	50° / 80° / Asym

## VIA UP&DOWN

850mm						
Option	Color T°	CRI	Difusor	Power	Lumen Output	Beam Angle
540	3000K	80	Opal / Microprisma	14 + 38W	1240 + 3809lm / 1323 + 3121lm	110° / 90°
630	4000K	80	Opal / Microprisma	14 + 38W	1278 + 3923lm / 1363 + 3214lm	110° / 90°
1130mm						
510	3000K	80	Opal / Microprisma	21 + 51W	2794 + 5112lm / 2794 + 4161lm	110° / 90°
600	4000K	80	Opal / Microprisma	21 + 51W	2878 + 5265lm / 2878 + 4286lm	110° / 90°
1130mm						
110	3000K	80	UGR<16 / UGR<19	24 + 32W	2794 + 3989lm / 2794 + 4104lm / 2794 + 3739lm	50° / 80° / Asym
120	4000K	80	UGR<16 / UGR<19	24 + 32W	2878 + 4109lm / 2878 + 4227lm / 2878 + 3851lm	50° / 80° / Asym

## VIA WALL LIGHT UP&DOWN

850mm						
Option	Color T°	CRI	Difusor	Power	Lumen Output	Beam Angle
545	3000K	80	Opal	14+38W	1240 + 3809lm	110°
635	4000K	80	Opal	14+38W	1278 + 3923lm	110°
1130mm						
515	3000K	80	Opal	21+51W	2794 + 5112lm	110°
605	4000K	80	Opal	21+51W	2878 + 5265lm	110°

## VIA RECESSED

580mm						
Option	Color T°	CRI	Difusor	Power	Lumen Output	Beam Angle
770	3000K	80	Opal / Microprisma	15W	1392lm / 1133lm	110° / 90°
750		80	Opal / Microprisma	25W	2506m / 2039m	110° / 90°
800	4000K	80	Opal / Microprisma	15W	1434lm / 1167lm	110° / 90°
780		80	Opal / Microprisma	25W	2581lm / 2100lm	110° / 90°
860mm						
0830	3000K	80	Opal / Microprisma	20W	2131lm / 1735lm	110° / 90°
0810		80	Opal / Microprisma	38W	3809lm / 3121lm	110° / 90°
0860	4000K	80	Opal / Microprisma	20W	2195lm / 1787lm	110° / 90°
0840		80	Opal / Microprisma	38W	3923lm / 3214lm	110° / 90°
1140mm						
0890	3000K	80	Opal / Microprisma	27W	2842lm / 2313lm	110° / 90°
0870		80	Opal / Microprisma	51W	5112lm / 4161lm	110° / 90°
0920	4000K	80	Opal / Microprisma	27W	2927lm / 2382lm	110° / 90°
0900		80	Opal / Microprisma	51W	5265lm / 4286lm	110° / 90°

## VIA WALL LIGHT

570mm						
Option	Color T°	CRI	Difusor	Power	Lumen Output	Beam Angle
595	3000K	80	Opal	15W	1392lm	110°
575		80	Opal	25W	2506m	110°
685	4000K	80	Opal	15W	1434lm	110°
665		80	Opal	25W	2581lm	110°
850mm						
565	3000K	80	Opal	20W	2131lm	110°
545		80	Opal	38W	3809lm	110°
655	4000K	80	Opal	20W	2195lm	110°
635		80	Opal	38W	3923lm	110°
1130mm						
535	3000K	80	Opal	27W	2842lm	110°
515		80	Opal	51W	5112lm	110°
625	4000K	80	Opal	27W	2927lm	110°
605		80	Opal	51W	5265lm	110°



110°



90°



50°

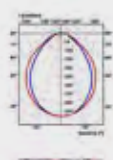

80°



Asym°



FONOVIA is a concept of linear light that isolates us from the environment, creating moments of concentration thanks to its fabric with sound-absorbing properties that in turn softens the light creating spaces of well-being. It accompanies moments of concentration and privacy. Fabric that favours acoustic absorption. Ideal for crowded spaces and meeting rooms.

FONOVIA es un concepto de luz lineal que nos aísla del entorno, creando momentos de concentración gracias a su tejido con propiedades fonoabsorbentes que a su vez suaviza la luz creando espacios de bienestar. Acompaña los momentos de concentración y de privacidad. Tejido que favorece la absorción acústica. Ideal para espacios concurridos y salas de reunión.

DESIGNED BY FAROLAB

# FONOVIA





**Fonovia 156**  
25W

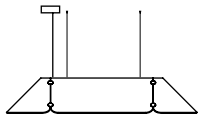

1560

**Fonovia 240**  
50W

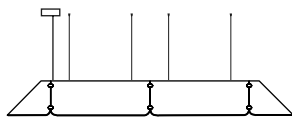

2400

**Fonovia**  
Custom



**FINISH**  
Acabado

● **Grey**  
Gris

**COLOR TEMPERATURE**  
Temperatura de color

3000K CRI>80

4000K CRI>80

# Highlights

## Recycled PET

**Because polyester accounts for approximately 60 percent of the world's production of PET, developing a non-virgin supply chain for polyester fiber has the potential to massively impact global energy and resource requirements.**

Debido a que el poliéster representa aproximadamente el 60 por ciento de la producción mundial de PET, el desarrollo de una cadena de suministro no virgen para la fibra de poliéster tiene el potencial de impactar masivamente los requerimientos globales de energía y recursos.



## Sound Absorbing $\alpha = 0.9$

**Noise in offices and workplaces has direct consequences on worker performance. The most immediate one is the reduction of their concentration. Workers exposed to continuous noise in their workplace are less effective in their work tasks. Concentration often means giving the brain a break to think better and focus on an activity. Luminaires made from fabrics with noise-absorbing properties are perfect for work spaces with high noise levels and acoustic distractions.**

El ruido en las oficinas y lugares de trabajo tiene consecuencias directas en el rendimiento de los trabajadores. La más inmediata es la reducción de su concentración. Los trabajadores expuestos a un ruido continuo en su lugar de trabajo son menos eficaces en sus tareas. La concentración suele significar dar un respiro al cerebro para pensar mejor y centrarse en una actividad. Las luminarias fabricadas con tejidos con propiedades de absorción del ruido son perfectas para espacios de trabajo con altos niveles de ruido y distracciones acústicas.







Office

## Beam Angle



90°

## FONOVIA 156cm 25W

incl. 50.000hs L80 / B10 MacAdam 3 110V 50 / 60Hz 650°C

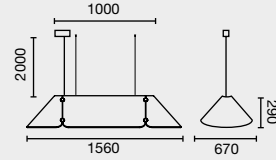

Reference	Finish	Power	Color T°	Lumen Output	Volt.
20110	● Grey	25W	3000K CRI>80	1800lm	-110 110V
20109	● Grey	25W	4000K CRI>80	1900lm	

## FONOVIA 240cm 50W

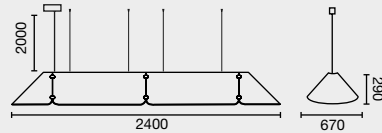

Reference	Finish	Power	Color T°	Lumen Output	Volt.
20107	● Grey	50W	3000K CRI>80	3600lm	-110 110V
20108	● Grey	50W	4000K CRI>80	3800lm	

Thanks to BEDEO relational/project



Need consulting  
for your project?  
¿Necesitas  
asesoramiento  
para tu proyecto?





CONFIGURE YOUR

# FONOVIA



# 1

Choose your via pendant composition  
*Escoge tu composición de via colgante*

## VIA SURFACE & SUSPENSION 850



Family	Power	Finish	Control System	Diffuser	Volt.	
04100 Via Evo	560	Surface 20W 3000K CRI80	1 White	ON/OFF	Opal	-110 110V
	540	Surface 38W 3000K CRI80	2 Black	D DALI	U Microprisma	
	650	Surface 20W 4000K CRI80				
	630	Surface 38W 4000K CRI80				

## VIA SURFACE & SUSPENSION 1130



Family	Power	Finish	Control System	Diffuser	Volt.	
04100 Via Evo	530	Surface 27W 3000K CRI80	1 White	ON/OFF	Opal	-110 110V
	510	Surface 51W 3000K CRI80	2 Black	D DALI	U Microprisma	
	620	Surface 27W 4000K CRI80				
	600	Surface 51W 4000K CRI80				
04102 Via Evo	110	Surface UGR 32W 3000K CRI80	1 White	ON/OFF	8 UGR<19 80°	-110 110V
	120	Surface UGR 32W 4000K CRI80	2 Black	D DALI	5 UGR<16 50°	
	111	Surface UGR 17W 3000K CRI80			0 UGR<19 asim.	
	121	Surface UGR 17W 4000K CRI80				

# 2

Choose your pendant accessory  
*Escoge tu accesorio colgante*

	Pendant Accessory	Pendant Accessory Dali
○	040000093	040000095
●	040000094	040000096



### 3

Dress your VIA EVO SYSTEM with fonovia sound absorbing shade system  
*Viste tu SISTEMA VIA EVO con el sistema de pantallas fonoabsorbentes fonovia*

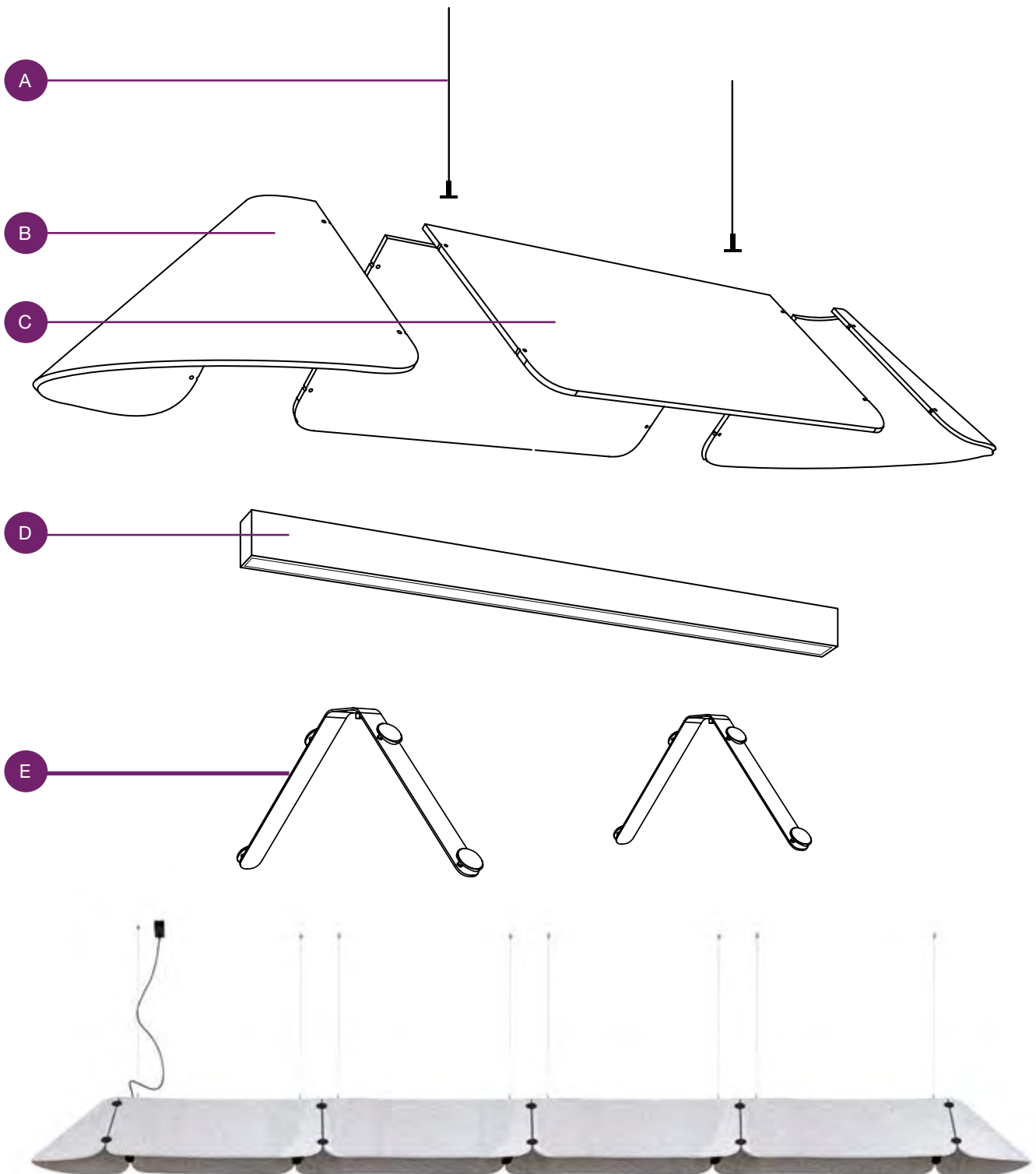

- Example **041005601W** — 4pc. x Via Evo Surface 20W 3000K CRI80 White Casambi  
**041080001** — 4pc. x 2ud.Fonovia Panels 837x400x9  
**040000094** — 1pc. x Pendant Accessory Black  
**040000098** — 4pc. x Accessory wire suspension  
**041080004** — 5pc. x Kit Soporte Fonovia Negro  
**041080003** — 1pc. x 2 Paneles Fonovia Conics



A

**Accessory wire suspension**  
Accesorio cables de suspensión  
**1pc.— 04000098**  
**For each VIA EVO**  
Por cada VIA EVO

**Pendant Accessory**  
Accesorio suspensión on/off  
**1pc.— ● 04000093**  
**1pc.— ● 04000094**  
**For each FONOVIA SYSTEM**  
Por cada FONOVIA SYSTEM

**Pendant Accessory DALI**  
Accesorio suspensión on/off  
**1pc.— ● 04000095**  
**1pc.— ● 04000096**  
**For each FONOVIA SYSTEM**  
Por cada FONOVIA SYSTEM



B

**For each complet system of VIA EVO**  
Para cada sistema completo de VIA EVO  
**1pc. — 041080003**  
**2 Fonovia Conics Panels 359x664x9**  
2 Paneles Fonovia Conics 359x664x9



C

**For each 850cm. VIA EVO**  
Por cada VIA EVO de 850cm.  
**1pc.— 041080001**  
**2 Fonovia Panels 837x400x9 Light Grey**  
2 Paneles Fonovia 837x400x9 Gris Claro

**For each 1130cm. VIA EVO**  
Por cada VIA EVO de 1130cm.  
**1pc. — 041080002**  
**2 Fonovia Panels 1117x400x9 Light Grey Claro**  
2 Paneles Fonovia 1117x400x9 Gris



D

**Choose your via pendant composition**  
Escoge tu composición de via colgante



E

**041080004 — Kit Soporte Fonovia Negro**  
**If you have 1 VIA EVO, use 2 supports.**  
**If you have 2 VIA EVO, use 3 supports.**  
**If you have 3 VIA EVO, use 4 supports.**  
**(always one unit more than the number of tracks)**

Si tienes 1 VIA EVO, usa 2 soportes.  
Si tienes 2 VIA EVO, usa 3 soportes.  
Si tienes 3 VIA EVO, usa 4 soportes.  
(siempre una unidad mas que del numero de vías)



L E D S T R I P





**LED STRIP**  
Tiras Led

**MONOCHROMATIC**  
Monocolor

**COB**

**IP67 NEON**

5 W	15 W	Tunable White	Neon IP67
9,6 W	19,2 W	RGB	

**INDEX PROTECTION**  
Índice de protección

IP20	IP66	IP67
------	------	------

**COLOR TEMPERATURE**  
Temperatura de color

2700K CRI80	3000K CRI80	4000K CRI80
2700-6500K	RGB	RGBW

**PROFILE**  
Perfiles

**RECESSED**  
Empotrables

**SURFACE**  
Superficie

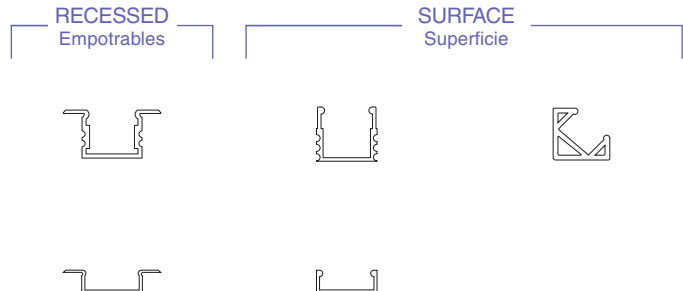

**FINISH**  
Acabado

● **Black**  
Negro

○ **White**  
Blanco

● **Silver**  
Plateado

**DIFFUSER**  
Difusor

○ **Transparent**

○ **Opal**



Thanks to EMMME Studio | Photo by Lupe Clemente

**Need consulting  
for your project?**  
¿Necesitas  
asesoramiento  
para tu proyecto?





Thanks to EMMME Studio | Photo by Lupa Clemente



Ledstrip

# LEDSTRIP MONOCHROMATIC 5W/m

no incl. 5mt. DIM MacAdam 3 24V CRI>80

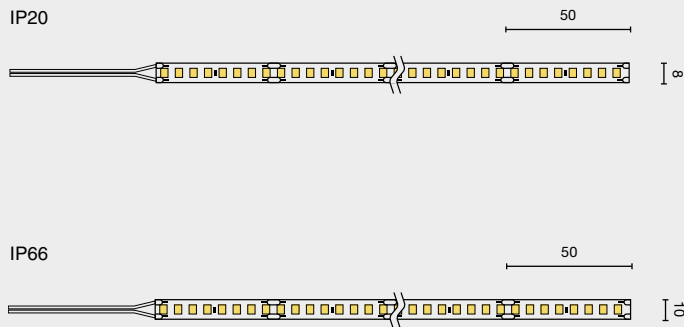

Ref	Power (W/m)	Color T°	lm output/m	LED/m	IP	Cut
08050306	5W	2700K	700	160 led/m	20	50 mm
08050307	5W	3000K	725	160 led/m	20	50 mm
08050308	5W	4000K	775	160 led/m	20	50 mm
08050901	5W	2700K	625	160 led/m	66	50 mm
08050902	5W	3000K	650	160 led/m	66	50 mm
08050903	5W	4000K	675	160 led/m	66	50 mm

\*Roll of 5m (500cm). You can order your own custom length every 10cm.  
Cut to measure: ref. -XX, where XX=length (-01=0,1m, -02=0,2m, -14=1,4m...)

\* Bobina de 5m (500cm) de longitud. Puede pedir su propia longitud personalizada cada 10cm.  
Corte a medida: ref. -XX, donde XX=longitud (-01=0,1m, -02=0,2m, -14=1,4m...)

# LEDSTRIP MONOCHROMATIC 9.6W/m

no incl. 5mt. DIM MacAdam 3 24V CRI>80

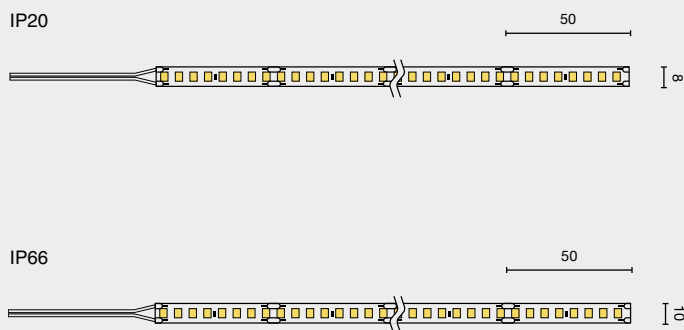

Ref	Power (W/m)	Color T°	lm output/m	LED/m	IP	Cut
08050106	9.6W	2700K	1300	160 led/m	20	50 mm
08050107	9.6W	3000K	1320	160 led/m	20	50 mm
08050108	9.6W	4000K	1360	160 led/m	20	50 mm
08050301	9.6W	2700K	1300	160 led/m	66	50 mm
08050302	9.6W	3000K	1320	160 led/m	66	50 mm
08050303	9.6W	4000K	1360	160 led/m	66	50 mm

\*Roll of 5m (500cm). You can order your own custom length every 10cm.  
Cut to measure: ref. -XX, where XX=length (-01=0,1m, -02=0,2m, -14=1,4m...)

\* Bobina de 5m (500cm) de longitud. Puede pedir su propia longitud personalizada cada 10cm.  
Corte a medida: ref. -XX, donde XX=longitud (-01=0,1m, -02=0,2m, -14=1,4m...)



Thanks to SEQURA Headquarters | Interior Designer: Mercè Font



Ledstrip



## LEDSTRIP MONOCHROMATIC 15W/m

no incl.  5mt.  DIM  MacAdam 3  24V CRI>80

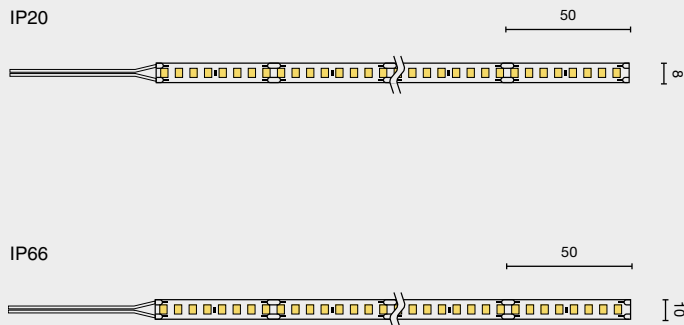

Ref	Power (W/m)	Color T°	lm output/m	LED/m	IP	Cut
08050406	15W	2700K	2025	160 led/m	20	50 mm
08050407	15W	3000K	2070	160 led/m	20	50 mm
08050408	15W	4000K	2175	160 led/m	20	50 mm
08050801	15W	2700K	1800	160 led/m	66	50 mm
08050802	15W	3000K	1845	160 led/m	66	50 mm
08050803	15W	4000K	1950	160 led/m	66	50 mm

\*Roll of 5m (500cm). You can order your own custom length every 10cm.  
Cut to measure: ref. -XX, where XX=length (-01=0,1m, -02=0,2m, -14=1,4m...)

\* Bobina de 5m (500cm) de longitud. Puede pedir su propia longitud personalizada cada 10cm.  
Corte a medida: ref. -XX, donde XX=longitud (-01=0,1m, -02=0,2m, -14=1,4m...)

## LEDSTRIP MONOCHROMATIC 19.2W/m

no incl.  5mt.  DIM  MacAdam 3  24V CRI>80

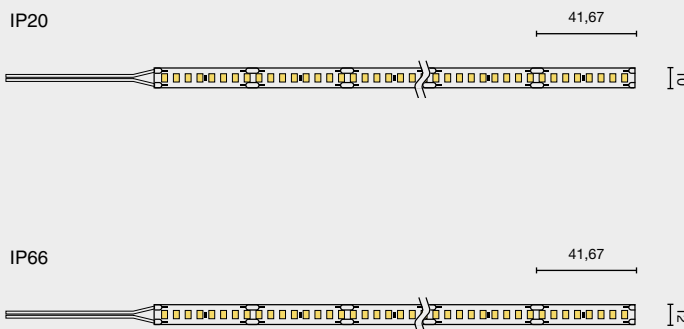

Ref	Power (W/m)	Color T°	lm output/m	LED/m	IP	Cut
08050201	19.2W	2700K	2500	192 led/m	20	41,67 mm
08050202	19.2W	3000K	2520	192 led/m	20	41,67 mm
08050203	19.2W	4000K	2600	192 led/m	20	41,67 mm
08050401	19.2W	2700K	2500	192 led/m	66	41,67 mm
08050402	19.2W	3000K	2520	192 led/m	66	41,67 mm
08050403	19.2W	4000K	2600	192 led/m	66	41,67 mm

\*Roll of 5m (500cm). You can order your own custom length every 12,5cm.  
Cut to measure: ref. -XXXX, where XXXX=length (-0115=0,125m, -1000=1m ...)

\* Bobina de 5m (500cm) de longitud. Puede pedir su propia longitud personalizada cada 12,5cm  
Corte a medida: ref. -XXXX, donde XXXX=longitud (-0125=0,125m, -1000=1m ...)

## ACCESSORIES

08050696	UNION ACCESSORY LED STRIP 8mm	Accesorio unión tira led 8mm
08050697	UNION ACCESSORY LED STRIP 10mm	Accesorio unión tira led 10mm
08050698	CONNECTOR CABLE ACCESSORY LED STRIP 8mm	Accesorio conector cable tira led 8mm
08050699	CONNECTOR CABLE ACCESSORY LED STRIP 10mm	Accesorio conector cable tira led 10mm



## LEDSTRIP COB TUNABLE WHITE

no incl.  5mt.  DIM  24V CRI>90

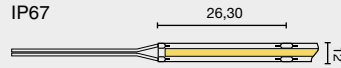
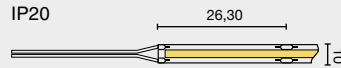

Ref	Power (W/m)	Color T°	lm output/m	IP	Cut
08050501	12W + 12W	2700-6500K	1080 + 1248	20	26,3 mm
08050511	12W + 12W	2700-6500K	1080 + 1248	67	26,3 mm

\*Roll of 5m (500cm). You can order your own custom lenght every 10,5cm.  
Cut to measure: ref. -XXX, where XXX=length (-0105=0,105m, -1052 =1,052m ...)

\* Bobina de 5m (500cm) de longitud. Puede pedir su propia longitud personalizada cada 10,5cm  
Corte a medida: ref. -XXX, donde XXX=longitud (-0105=0,105m, -1052 =1,052m ...)

## LEDSTRIP COB RGB

no incl.  5mt.  DIM  24V

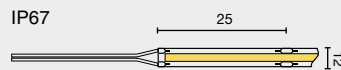
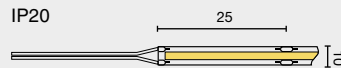

Ref	Power (W/m)	Color T°	lm output/m	IP	Cut
08050601	15W	RGB	550	20	25 mm
08050611	15W	RGB	550	67	25 mm

\*Roll of 5m (500cm). You can order your own custom lenght every 10cm.  
Cut to measure: ef. -XXX, where XX=length (-01 =0,1m, -02=0,2m, -14=1,4m...)

\* Bobina de 5m (500cm) de longitud. Puede pedir su propia longitud personalizada cada 10cm  
Corte a medida: ref. -XXX, donde XX=length (-01 =0,1m, -02=0,2m, -14=1,4m...)

## LEDSTRIP RGB WHITE

no incl.  5mt.  DIM  24V



Ref	Power (W/m)	Color T°	lm output/m	IP	Cut
08050706	24w	RGBWhite	1368	20	62mm

\*Roll of 5m (500cm). You can order your own custom lenght every 10cm.  
Cut to measure: ef. -XXX, where XX=length (-01 =0,1m, -02=0,2m, -14=1,4m...)

\* Bobina de 5m (500cm) de longitud. Puede pedir su propia longitud personalizada cada 10cm  
Corte a medida: ref. -XXX, donde XX=length (-01 =0,1m, -02=0,2m, -14=1,4m...)





Need consulting  
for your project?  
¿Necesitas  
asesoramiento  
para tu proyecto?



## LEDSTRIP NEON FRONT

IP67 5mt. DIM

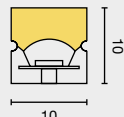
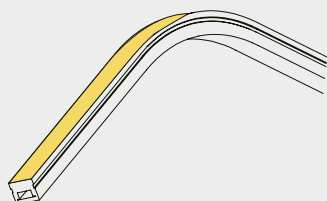
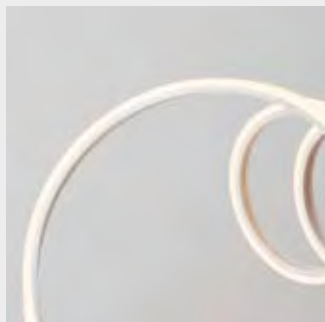

Ref	Power (W/m)	Color T°	lm output/m	IP	Cut
08045001	14W	2700K	1060	67	125mm
08046001	14W	3000K	1060	67	125mm

\*Roll of 5m (500cm). You can order your own custom length every 125mm.  
Cut to measure: ref.-XX, where XX=length. (-125 (125mm); -250 (250mm); -1000 (1000mm)...)

\*Bobina de 5m (500cm). Puede pedir su propia longitud personalizada cada 125mm.  
Corte a medida: ref.-XX, donde XX=longitud. (-125 (125mm); -250 (250mm); -1000 (1000mm)...)

## ACCESSORIES



08040098	ALUMINIUM CLIP	Clip de aluminio
----------	----------------	------------------

## LEDSTRIP NEON SIDE

IP67 5mt. DIM

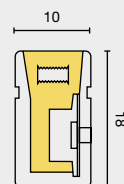
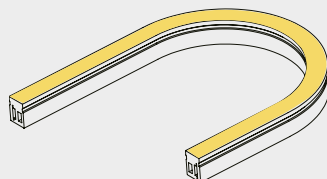

Ref	Power (W/m)	Color T°	lm output/m	IP	Cut
08047001	14W	2700K	470	67	125mm
08048001	14W	3000K	470	67	125mm

\*Roll of 5m (500cm). You can order your own custom length every 125mm.  
Cut to measure: ref.-XX, where XX=length. (-125 (125mm); -250 (250mm); -1000 (1000mm)...)

\*Bobina de 5m (500cm). Puede pedir su propia longitud personalizada cada 125mm.  
Corte a medida: ref.-XX, donde XX=longitud. (-125 (125mm); -250 (250mm); -1000 (1000mm)...)

## ACCESSORIES



08040099	ALUMINIUM CLIP	Clip de aluminio
----------	----------------	------------------





Ledstrip

## LEDSTRIP PROFILES

### SURFACE PROFILES

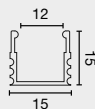
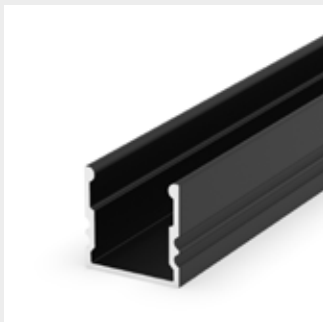

Ref	Finish	Long
08060101N	● Black	2000 mm
08060101B	○ White	2000 mm
08060101	● Silver	2000 mm

Ref	Accessorie	Finish
08060204N	End cap (2 pcs)	● Black
08060204B	End cap (2 pcs)	○ White
08060204	End cap (2 pcs)	● Silver

### SURFACE PROFILES 8MM



Ref	Finish	Long
08080101N	● Black	2000 mm
08080101B	○ White	2000 mm
08080101	● Silver	2000 mm

Ref	Accessorie	Finish
08080204N	End cap (2 pcs)	● Black
08080204B	End cap (2 pcs)	○ White
08080204	End cap (2 pcs)	● Silver

### SURFACE PROFILES 45°

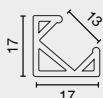
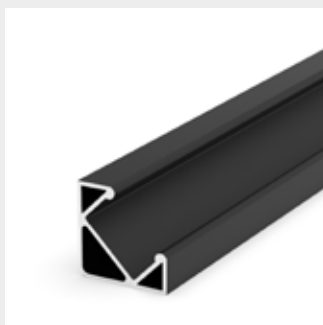

Ref	Finish	Long
08050101N	● Black	2000 mm
08050101B	○ White	2000 mm
08050101	● Silver	2000 mm

Ref	Accessorie	Finish
08050204N	End cap (2 pcs)	● Black
08050204B	End cap (2 pcs)	○ White
08050204	End cap (2 pcs)	● Silver

## RECESSED PROFILES

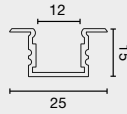
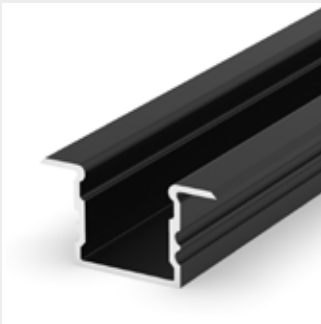

Ref	Finish	Long
08090101N	● Black	2000 mm
08090101B	○ White	2000 mm
08090101	● Silver	2000 mm

Ref	Accessorie	Finish
08070204N	End cap (2 pcs)	● Black
08070204B	End cap (2 pcs)	○ White
08070204	End cap (2 pcs)	● Silver

## RECESSED PROFILES 8MM

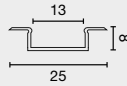
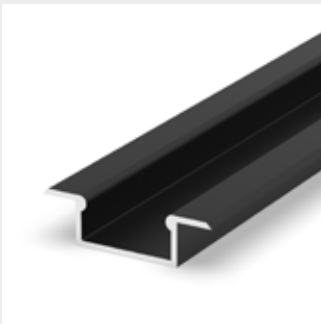

Ref	Finish	Long
08090111N	● Black	2000 mm
08090111B	○ White	2000 mm
08090111	● Silver	2000 mm

Ref	Accessorie	Finish
08090204N	End cap (2 pcs)	● Black
08090204B	End cap (2 pcs)	○ White
08090204	End cap (2 pcs)	● Silver

## OPAL DIFFUSER

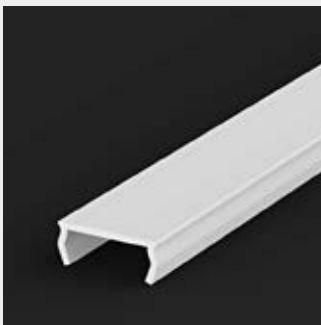

Ref	Long
0806202	2000 mm

## TRANSPARENT DIFFUSER

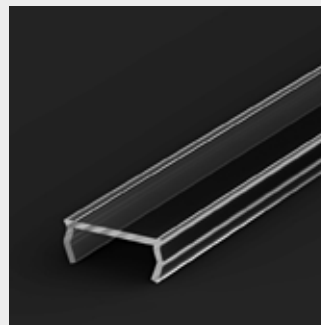

Ref	Long
0806203	2000 mm

## CLIPS



08050105 ● Surface profile clip 45°



08060105 ● Surface & 15mm recessed clip



**Light Colour**  
Control de luz



**Sunrise & Sunset**  
Amanecer y atardecer



**Calendar & Timer**  
Calendario y Temporizador



**Colour Color T°**  
Color Color T°



**Grouping**  
Agrupación



**Scenes**  
Escenas



**Animations**  
Animaciones



**Gallery**  
Galería



**Daylight Sensor**  
Sensor de luz diurna



**Occupancy Sensor**  
Sensor de ocupación

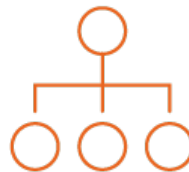

**Control Hierarchy**  
Jerarquía de control

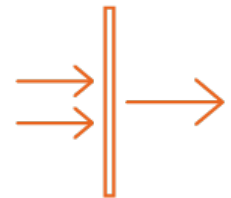

**Gateway**  
Entrada

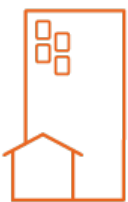

**Scalability**  
Escalabilidad



**Synchronization**  
Sincronización



**Elements**  
Elementos



**Parameters**  
Parámetros

This range of control elements offers customized solutions to optimize specific environments. Easily create dynamic spaces and energy efficient through control of lighting.



**CASAMBI**  
SMART  
LIGHTING

Esta gama de elementos de control ofrece soluciones personalizadas para optimizar entornos específicos. Crea fácilmente espacios dinámicos y eficientes desde el punto de vista energético mediante el control de la iluminación.



# Switch & Controls

## Switch for CASAMBI installations control



97534



97533

Allows dimming, calling scenes, controlling groups, all lamps and sequences. Works with Casambi APP and Casambi Models. Black or white colour. Lithium CR2430 battery, duration 2-5 years. Open range 60 metres. 4 general purpose buttons (scenes, individual, groups, sequences) plus 2 regulation buttons and 2 other buttons programmable by the Casambi APP.

Permite regular, llamar a escenas, controlar grupos, todas las lámparas y secuencias. Funciona con la APP de Casambi y Modelos Casambi. Color negro o blanco. Pila CR2430 de Litio, duración 2-5 años. Alcance en abierto 60 metros. 4 botones de propósito general (escenas, individual, grupos, secuencias) más 2 botones de regulación y otros 2 botones programables por la APP de Casambi.

## Switch 55



97536 Matt Anthracite Antracita Mate

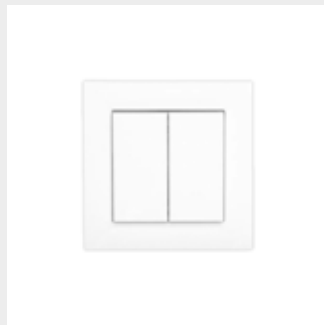

97537 Matt White Blanco Mate

4-channel bluetooth wireless push button with 2 keys. Completely autonomous (no battery or power supply), it works by mechanical impulses. It sends a radio signal thanks to the energy released when the keys are pressed and requires no maintenance.

Pulsador inalámbrico bluetooth de 4 canales mediante 2 teclas. Completamente autónomo (sin pila ni alimentación), funciona mediante impulsos mecánicos. Envía una señal de radio gracias a la energía liberada durante las pulsaciones de las teclas y no requiere mantenimiento.

# Sensors

## Recessed Sensor



97542

## Surface Sensor



97543

Bluetooth light level and presence sensor in recessed or surface format. Through the CASAMBI App, it can be configured to activate scenes, luminaires, when it detects presence, according to illuminance or circadian scenes. Recommended installation height between 2.4 and 5m. Detection diameter between 5 and 7m.

Sensor bluetooth de nivel de luz y presencia en formato de empotrar o superficie. A través de la App de CASAMBI se puede configurar para activar escenas, luminarias, cuando detecte presencia, según la iluminancia o escenas circadianas. Altura de instalación recomendada entre 2,4 y 5m. Diámetro de detección entre 5 y 7m.

# Auxiliary Devices

## CBU-DCS Bluetooth DALI controller



97530

CBU-DCS is a Bluetooth controllable, Casambi enabled DALI controller. CBU-DCS does not have its own power supply. Instead, it is powered directly from a DALI bus.

CBU-DCS es un controlador DALI controlado por Bluetooth y habilitado por Casambi. CBU-DCS no tiene su propia fuente de alimentación. En su lugar, se alimenta directamente de un bus DALI.

## Dimming for LED strips



97538

Dimming by CASAMBI for LED strips. 4 output channels. Max. total current 6 Ampere. Without push button input.

Regulación por CASAMBI para tiras LED. 4 canales de salida. Corriente máxima en total 6 Amperios. Sin entrada de pulsador.

## CASAMBI to DALI converter



97531

Built-in 120mA DALI source. Broadcast output, 4 groups, DT8 or RGBW. To control up to 60 DALI luminaires all at the same time.

Fuente DALI integrada de 120mA. Salida en Broadcast, 4 grupos, DT8 o RGBW. Para controlar hasta 60 luminarias DALI todas a la vez.

## Casambi PWM4 IP65



97539

IP65 CBU-PWM4. CBU-PWM4 en formato IP65.

## Plug & Play – Switch



97540

Smart plug adapter for luminaires and electrical appliances. High switching capacity – up to 3680 W.

Adaptador de enchufe inteligente para luminarias y aparatos eléctricos. Gran capacidad de conmutación: hasta 3680W.



97541

## Timer-Casambi



97544

TIMER-CASAMBI is a device that allows to keep memory of Casambi timers for scenarios when power supply is missing or because of a temporarily black-out. TIMER-CASAMBI es un dispositivo que permite mantener la memoria de los temporizadores Casambi para los escenarios en los que falta la alimentación eléctrica o debido a un apagón temporal.

# Dali elements

## Dali Touchpanel Basic C



97545

Capacitive touch panel with glass screen. Allows switching on, off and dimming of up to 3 groups or scenes of luminaires. Powered by DALI bus.

Panel táctil capacitivo con pantalla de cristal. Permite el encendido, apagado y regulación de hasta 3 grupos o escenas de luminarias. Alimentación por bus DALI.

## Dali Touchpanel Basic TW



97546

Allows easy control of Tuneable White luminaires via DALI protocol. Permite controlar fácilmente las luminarias Tuneable White mediante protocolo DALI.

## Dali USB Programmer



97547

USB interface module for DALI system. Accessory for connecting software tools for addressing, programming and parameterisation of DALI installations and Faro Barcelona devices.

Módulo interfaz USB para sistema DALI. Accesorio para conectar herramientas software para direccionamiento, programación y parametrización de instalaciones DALI y dispositivos Faro Barcelona.

## Dali PS1 Power Supply



97548

4W DALI power supply for stand-alone mounting, Accessory for supplying 200mA to DALI devices or control modules without their own standard power supply. Powered at 230-240V; 50/60Hz.

Alimentador DALI de 4W para montaje independiente, Accesorio para suministrar 200mA a dispositivos DALI o módulos de control sin su propia fuente de alimentación estándar. Alimentado a 230-240V; 50/60Hz.

## Recessed Dali Sensor



97549

Light level and presence sensor using DALI protocol. Recessed and surface mounting format. Allows simple switching on, switching off and dimming of individual luminaires, groups of luminaires or scenes, either by presence or brightness detection. Power supply via DALI bus.

Sensor de nivel de luz y presencia mediante protocolo DALI. Formato de empotrar y superficie. Permite encender, apagar y regular de forma simple luminarias individuales, grupos de luminarias o escenas, ya sea por detección de presencia o luminosidad. Alimentación mediante Bus DALI.

## Surface Dali Sensor



97550

**Today's technology makes it possible to integrate thousands of luminaires and control functions into a single system based on a DALI control network or even centralise it in a BMS system. At Faro Barcelona we have concentrated all our experience and knowledge on simple solutions helping to find the necessary control elements to customise an installation.**

**Despite the complexity and size of the lighting installations, only a few components are needed to manage the entire system: Luminaires with DALI driver, DALI sensors (multisensors), DALI pushbuttons, DALI buttons, DALI Bus feeder and routers as a control unit.**

La tecnología actual permite integrar miles de luminarias y funciones de control en un solo sistema basado en una red DALI de control o incluso centralizarlo en un sistema BMS. En Faro Barcelona hemos concentrado toda nuestra experiencia y conocimientos en soluciones simples ayudando a encontrar los elementos de control necesarios para personalizar una instalación.

A pesar de la complejidad y el tamaño de las instalaciones de iluminación, solo se necesitan algunos componentes para gestionar todo el sistema: Luminarias con driver DALI, sensores (multisensores) DALI, pulsadores DALI, botonas DALI, alimentador de Bus DALI y routers como unidad de control.

DALI and DALI-2 are open lighting standards. It is a digital protocol used worldwide to control lighting components, it allows to transfer information such as lighting commands, fault data, consumption and diagnostics between different devices.



# SMART LIGHTING

DALI y DALI-2 son estándares abiertos de iluminación. Es un protocolo digital usado en todo el mundo para controlar componentes de iluminación, permite transferir información como los comandos de iluminación, los datos de fallos, consumos y los diagnósticos entre distintos dispositivos.







# 24V Power Supply

98324015U

Constant voltage power supply for 24V DC. Supplies up to 12W, 100-240V, 50/60Hz

Fuente de alimentación de voltaje constante para 24V DC. Suministra hasta 12W, 100-240V, 50/60Hz



98324100UD

Constant voltage power supply for 24V DC. Supplies up to 100W, 110-240V, 50/60Hz. DALI

Fuente de alimentación de voltaje constante para 24V DC. Suministra hasta 100W, 110-240V, 50/60Hz. DALI

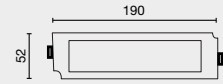

98324200

Constant voltage power supply for 24V DC. Supplies up to 200W, 120-240V, 50/60Hz.

Fuente de alimentación de voltaje constante para 24V DC. Suministra hasta 200W, 120-240V, 50/60Hz. Con protección clasificada en IP67

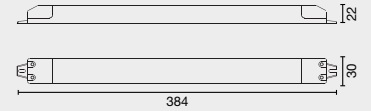

# Simbology

	Luminaires of insulation class I are provided with a connection for the earthing conductor (PE) and are not specially marked.	Las luminarias de la clase de aislamiento I están provistas de una conexión para el conductor de puesta a tierra (PE) y no están identificadas de forma especial.
	Luminaires with insulation class II	Luminarias con clase de aislamiento II
	Luminaires with insulation class III	Luminarias con clase de aislamiento III
 incl.	Driver included	Equipo electrónico incluido
 no incl.	Driver not included	Equipo electrónico no incluido
 2mt.	Cable meters	Metros de cable
 50.000hs L80/B10	LED lifetime	Vida útil LED
 20°	Cardanic orientation	Orientación cardánica
 355°	Vertical orientation degrees	Grados de orientación vertical
 355°	Horizontal orientation degrees	Grados de orientación horizontal
 30°	Vertical orientation degrees	Grados de orientación vertical
 30°	Vertical orientation degrees	Grados de orientación vertical
 850°C	Compliance of incandescent wire regulatory	Cumplimiento de la normativa incandescente de alambre.
	Cut out	Agujero para empotrar
	MacAdam ellipses	Elipses de MacAdam
	Dimmers are devices used to vary the brightness of a light.	Los Dimmers son dispositivos utilizados para variar la intensidad de la luz.
	Tunable White. Luminaires with variable colour temperature control from warm white to cool white.	Tunable White. Luminarias con control variable de la temperatura de color desde la luz blanca cálida hasta el blanco frío.
	Unified Glare Rating	Unified Glare Rating Índice de Deslumbramiento Unificado

TRUE BEAUTY  
RESIDES  
IN SIMPLICITY.  
IN EVERY SMALL  
MOMENT WE  
DISCOVER  
THE EXTRAORDINARY.